

RAIL: STAINLESS STEEL RAIL 10'-1" LONG PART# 24S057000	BRACKETS: ALUMINUM HEAVY DUTY "H" BRACKET PART #: 24F195003 NO. BRACKETS REQUIRED:	BRACKETS: EXTRUSION PART #:24A273000 NO. EXTRUSION REQ UIRED:	WALL MOUNT HARDWARE: 1/4-20 x 3" HEX HEAD BOLT (90H281004) 1/4-20 x 2" TOGGLE (90H019004) 1/4" LOCK WASHER (90H009003)
QTY:	QTY:	QTY:	QTY:

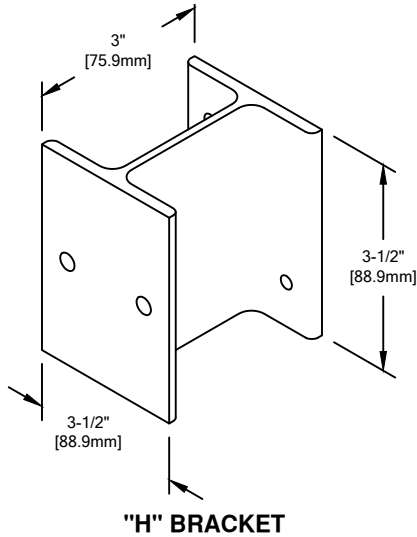

**CONTRACTOR NOTES:**

1. ALL DIMENSIONS MUST BE FIELD VERIFIED TO A 1/16" TOLERANCE.
2. DIMENSIONS TO BE OBTAINED AT THE ELEVATION OF MATERIAL LOCATION. ALSO, MOUNTING CONDITION TO BE VERIFIED. FABRICATION CANNOT BEGIN WITHOUT THIS INFO.
3. SOME DIMENSIONS SMALLER THAN 16" MAY BE TOO SMALL TO FABRICATE.

**NOTES:**

1. ALL RAIL TO BE SUPPLIED PREFABRICATED TO REQUIRED LENGTH. ALL CORNERS AND END CAPS TO BE FACTORY FORMED TO SUIT FIELD CONDITIONS.
2. ALL UNITS TO BE PRE-DRILLED FOR ATTACH. HOLE SPACING TO BE DETERMINED BY UNIT LENGTH, SPACING NOT TO EXCEED 32" ON CENTER.
3. ALL MOUNTING HARDWARE TO BE SUPPLIED FOR FIELD ASSEMBLY AND INSTALLATION.
4. MATERIAL:  
CS ECR-32S CRASH RAIL SHALL BE MANUFACTURED FROM A 4" WIDE x 1/4" THICK EXTRUSION (#304 STAINLESS STEEL). DESIGNED FRO ELASTIC DEFORMATION UNDER IMPACT WITHOUT DAMAGING THE WALL TO WHICH IT HAS BEEN MOUNTED.
5. FINISH:  
THE ECR-32S CRASH RAIL SHALL BE FURNISHED WITH A 120 GRIT MECHANICAL #4 SATIN FINISH.

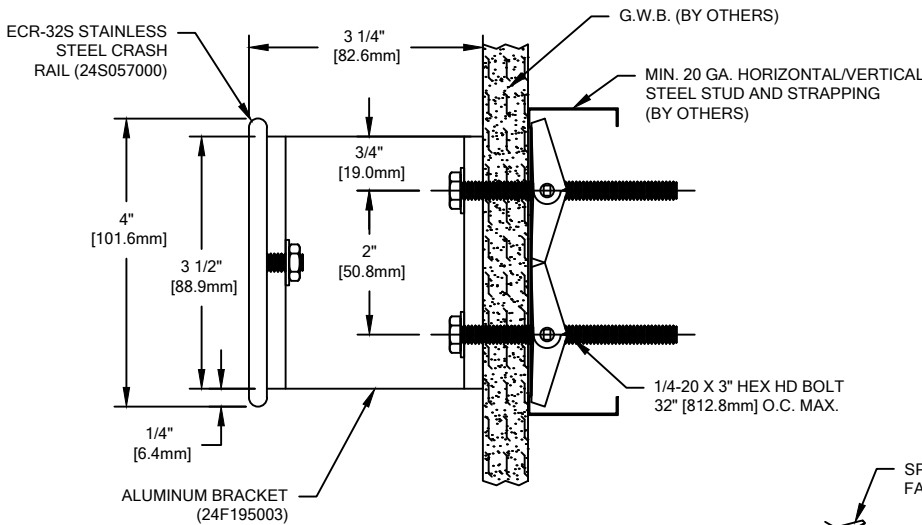

**ECR-32S  
HIDDEN FASTENERS**

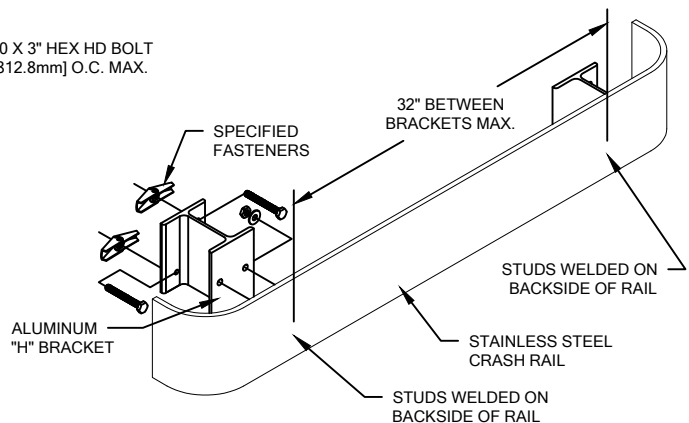

 <p>Hughesville, PA   800.233.8493   570.546.5941 Mississauga, ON   888.895.8955   905.274.3611 <a href="http://www.c-sgroup.com">www.c-sgroup.com</a></p> <p>© Copyright 2017 Construction Specialties, Inc.</p>	<b>PROJECT:</b>	<b>REVISION:</b>
	<b>JOB NO.:</b>	<b>F&amp;F:</b>
	<b>CUSTOMER:</b>	
	<b>REP:</b>	<b>DATE:</b>
	<b>DRAWN BY:</b>	<b>SHEET NO:</b>