

QTY. REQ'D	UNIT HEIGHT

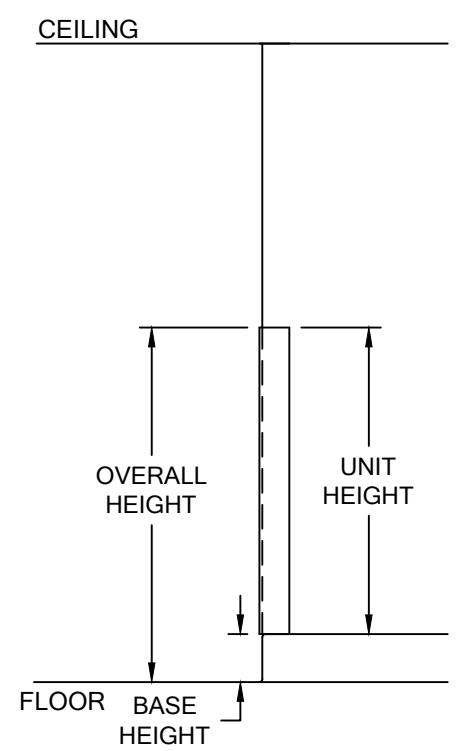
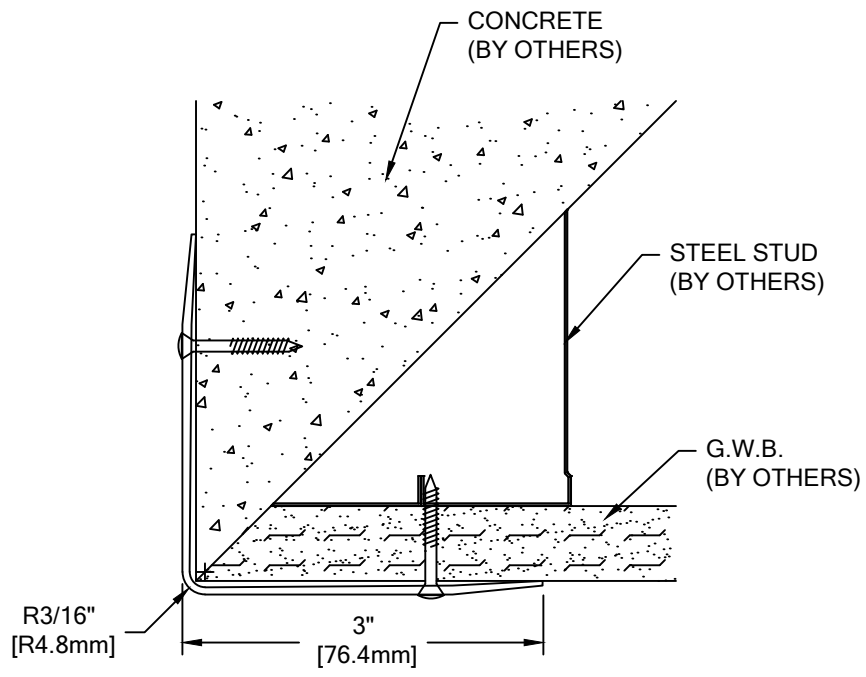

LG-300 CORNER GUARD
AT PARTIAL HEIGHT ELEVATION

LG-300

WALL CONDITION	SPECIFIED FASTENER	DRILL DIAMETERS		CS PART NUMBER
		WALL	RETAINER	
STEEL STUD/GYPSUM WALL WOOD STUD/GYPSUM WALL CONCRETE/CONC. BLOCK	LG 034 1 1/8" SCREW/NAIL LG 118/150/200/250 1" SCREW NAIL	N/A	N/A	90H136002 90H135002

NOTE: LG CORNER GUARDS THAT ARE REQUESTED WITHOUT PRE-DRILLED HOLES DO NOT INCLUDE FASTENERS WITH THE EXCEPTION OF MODEL LG-034. FOR MODEL LG-034, FASTENERS ARE ALWAYS SUPPLIED, AND HOLES ARE NOT PRE-DRILLED.

 Hughesville, PA 800.233.8493 570.546.5941 Mississauga, ON 888.895.8955 905.274.3611 www.c-sgroup.com © Copyright 2017 Construction Specialties, Inc.	PROJECT:	REVISION:
	JOB NO.:	F&F:
	CUSTOMER:	
	REP:	DATE:
	DRAWN BY:	SHEET NO: