

SCR-64M CRASH RAIL

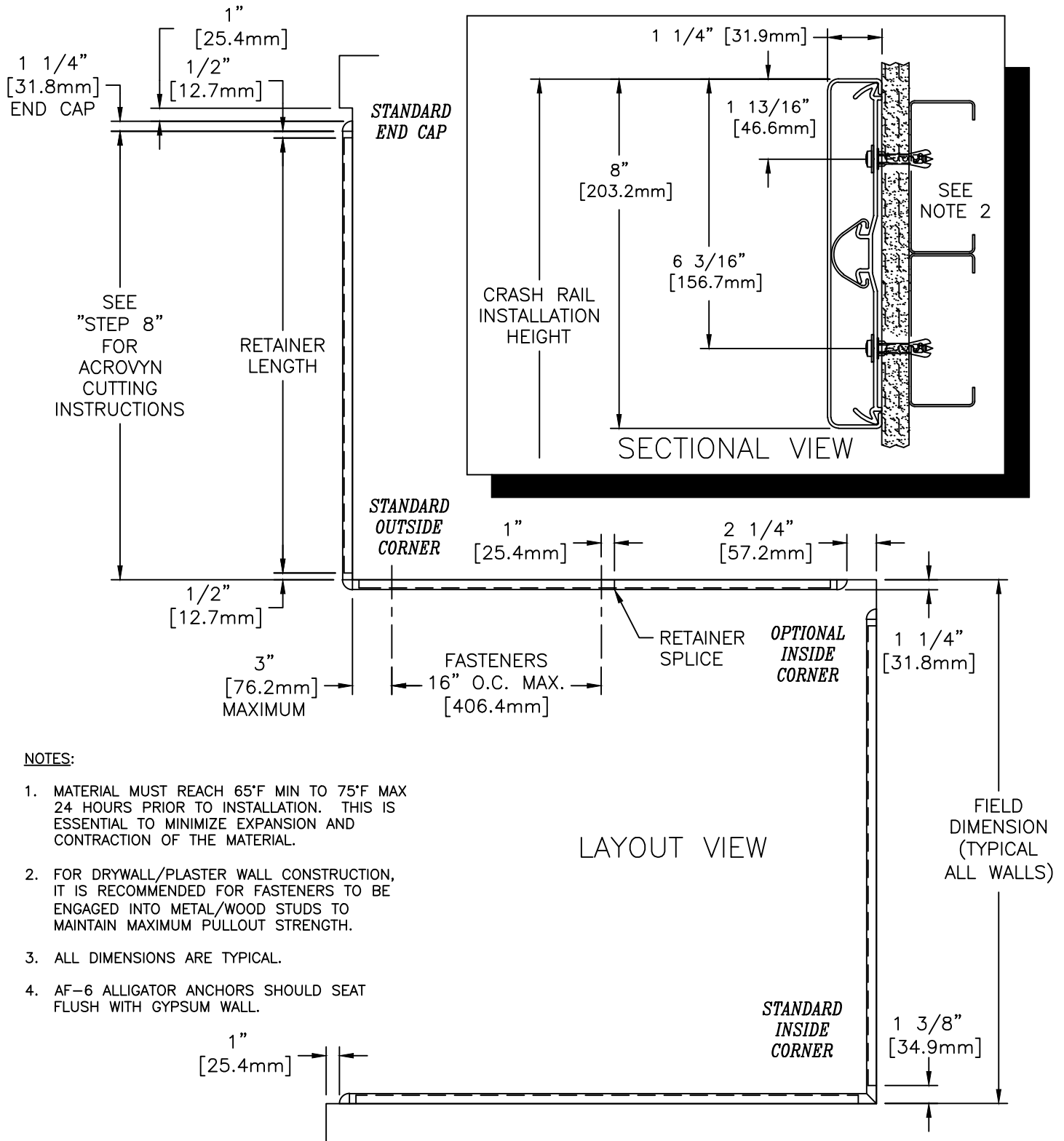

SCR-64M CRASH RAIL



ACROVYN CRASH
RAIL COVER
(24U042xxx)



ACROVYN CRASH
RAIL RETAINER
(24A274000)



CONTINUOUS VINYL
BUMPER
(24U804108)

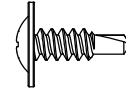

FASTENER #1
#8 X 1/2"
PHILLIPS WAFER
HEAD TEK SCREW
(90H086002)

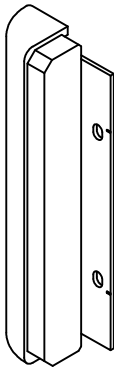

CRASH RAIL END CAP
(24I078xxx)

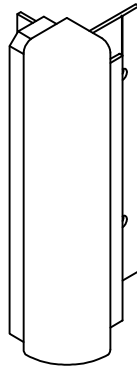

CRASH RAIL OUTSIDE
CORNER ASSEMBLY



ACROVYN SPLICE COVER
(24F227108)



ACROVYN SPLICE
COVER RETAINER
(24F228000)

WALL CONDITION	SPECIFIED FASTENER	DRILL DIAMETERS		C/S PART NUMBER
		WALL	RETAINER	
CONCRETE/CONCRETE BLOCK	#10 X 1 1/2" PHILLIPS PAN HEAD SMS 1/4" FLAT WASHER SAE AF-6 ALLIGATOR ANCHORS	1/4"	9/32"	90H189002 90H007003 90H039004
STEEL STUD/GYPSUM WALL	#10 X 1 1/2" PHILLIPS PAN HEAD SMS 1/4" FLAT WASHER SAE AF-6 ALLIGATOR ANCHORS	1/4"	9/32"	90H189002 90H007003 90H039004
WOOD STUD/GYPSUM WALL	#9 X 2 1/4" WAFER HD PH DRYWALL SCREW 1/4" FLAT WASHER SAE	N/A	N/A	90H421002 90H007003

SCR-64M CRASH RAIL

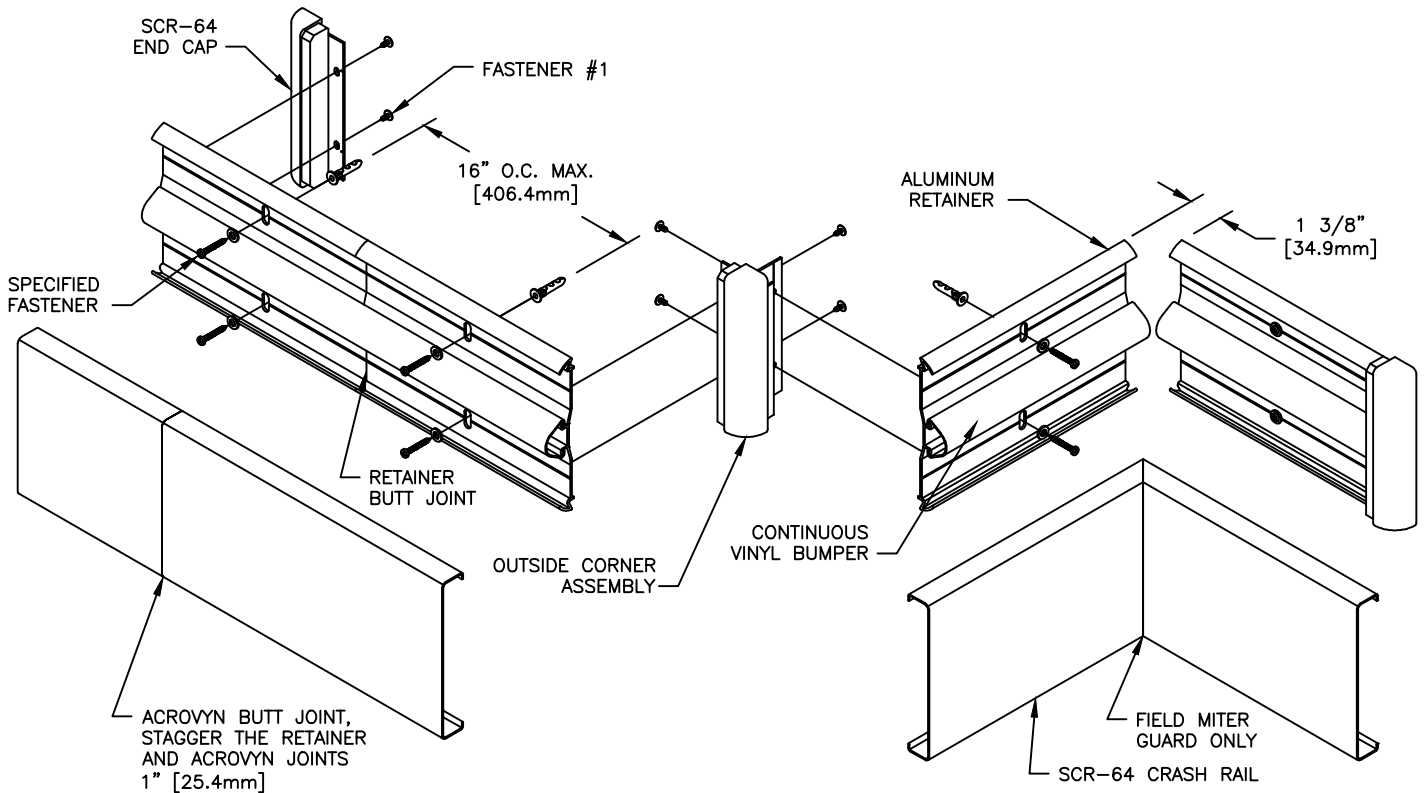

FIGURE 1.

1. ESTABLISH CRASH RAIL HEIGHT ABOVE FINISH FLOOR. DEDUCT 1-13/16" [46.6mm] AND 6-3/16" [156.7mm] AND SNAP A CHALK LINE AT THAT HEIGHT. THIS MARKS THE LOCATION OF THE RETAINER FASTENERS.
2. CUT THE CONTINUOUS ALUMINUM RETAINER AND THE CONTINUOUS VINYL BUMPER TO LENGTH, USING THE REQUIRED DEDUCTIONS AS NOTED (SEE LAYOUT VIEW). PRE-DRILL CLEARANCE HOLES IN THE ALUMINUM RETAINER 16" [406.4mm] O.C. AS REQUIRED (SEE FIGURE 1)(SEE NOTE 2 AND CHART ON PAGE 2).

NOTE: IT IS RECOMMENDED THAT THE ACROVYN COVERS AND ALUMINUM RETAINER BE CUT WITH A 100 TOOTH CARBIDE TIPPED SAW BLADE OR EQUIVALENT.

3. USING THE RETAINER AS A TEMPLATE, MARK THE LOCATION OF THE FASTENERS (SEE NOTE 2). USE A LEVEL TO ENSURE RETAINER IS PLUMB. DRILL CLEARANCE HOLES IN WALL SURFACE FOR MOUNTING HARDWARE (SEE CHART ON PAGE 2).
4. ATTACH THE CONTINUOUS VINYL BUMPER BY ALIGNING IT WITH THE ALUMINUM RETAINER AND SNAPPING IT INTO PLACE.
5. ATTACH THE ACROVYN SPLICE COVER TO THE APPROPRIATE RETAINERS BY SNAPPING THEM INTO PLACE. REMOVE THE PROTECTIVE COVERING FROM THE FACTORY APPLIED ADHESIVE AND ATTACH THE ASSEMBLY TO THE RETAINER AT ALL ACROVYN SPLICE JOINTS. (SEE FIGURE 2)
6. ATTACH END CAPS/OUTSIDE CORNERS BY ALIGNING THE END CAP/OUTSIDE CORNER WITH THE END OF THE ALUMINUM RETAINER AND SECURING INTO POSITION USING TWO 1/2" WAFER HEAD TEK SCREWS AT EACH END CAP AND FOUR AT EACH OUTSIDE CORNER (SEE DETAIL ABOVE).

NOTE: TO AID IN LOCATING THE END CAPS CORRECTLY, CUT A 4" [101.6mm] SECTION OF GUARD FROM SCRAP AND SNAP IT ON THE RETAINER. LOCATE THE CAP SO IT ALIGNS FLUSH WITH TOP AND BOTTOM OF THE GUARD.

SCR-64M CRASH RAIL

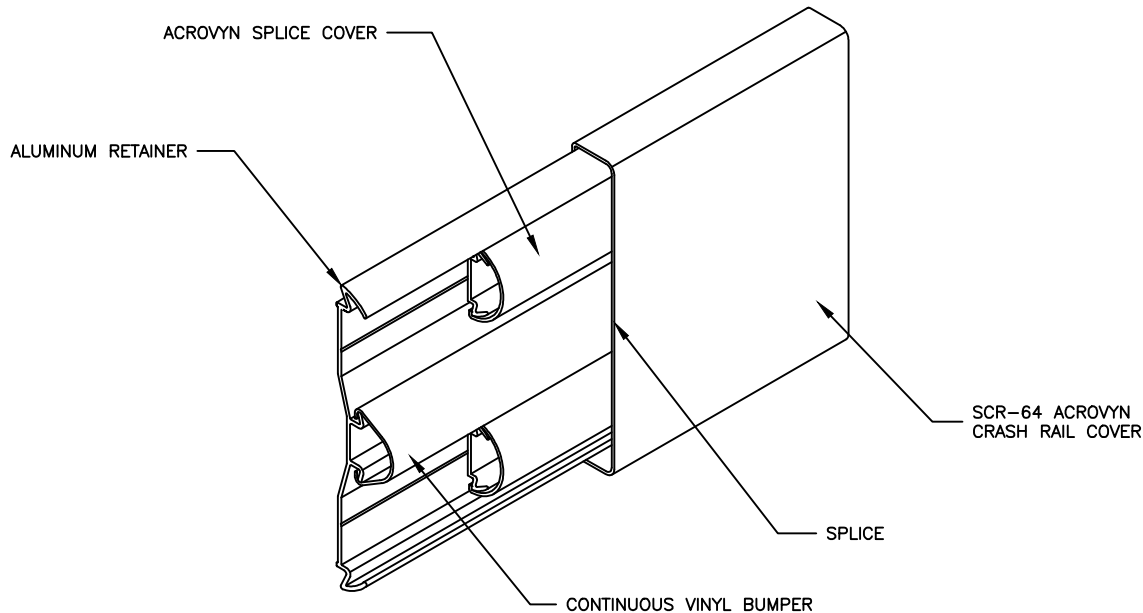

FIGURE 2.

7. INSTALL EACH SECTION OF ASSEMBLED RETAINER, IN SUCCESSION, USING THE APPROPRIATE HARDWARE. USE A LEVEL TO INSURE RETAINER IS PLUMB.
8. CUT THE ACROVYN COVER TO THE PROPER LENGTH. THE COVER LENGTH IS DETERMINED BY MEASURING THE DISTANCE BETWEEN THE INSTALLED END CAPS AND/OR INSIDE/OUTSIDE CORNER ASSEMBLIES.

NOTE: IT IS RECOMMENDED THAT THE ACROVYN COVERS BE CUT SLIGHTLY LONGER (1/32" UP TO 5'-0", 1/16" OVER 5'-0") THAN THE MEASURED DISTANCE. THIS ADDITIONAL LENGTH WILL PROVIDE FOR A TIGHTER GUARD-TO-END CAP FIT.

9. ALIGN THE TOP OF THE ACROVYN COVER WITH THE TOP OF THE ALUMINUM RETAINER AND SNAP THE GUARD ONTO THE BOTTOM SECTION OF THE RETAINER.

NOTE: MANUFACTURER RECOMMENDS ALL PRINTED "PRODUCT IDENTIFICATION" ON THE REAR OF THE ACROVYN PROFILE SHALL BE ORIENTED IN THE SAME DIRECTION DURING INSTALLATION TO ENSURE PROPER ALIGNMENT AT SPLICE BUTT JOINTS.

1/4/10