

COLOR: _____
 HANDRAIL WOOD SPECIES: _____
 HANDRAIL WOOD FINISH: _____
 COLOR TO BE SELECTED FROM ONE OF CS STANDARD COLORS.

TOTAL L/F REQ'D	LEFT END CAPS	RIGHT END CAPS

NOTES:

1. THIS MODEL IS FABRICATED CUT-TO-SIZE, THEREFORE FIELD VERIFIED DIMENSIONS ARE REQUIRED.

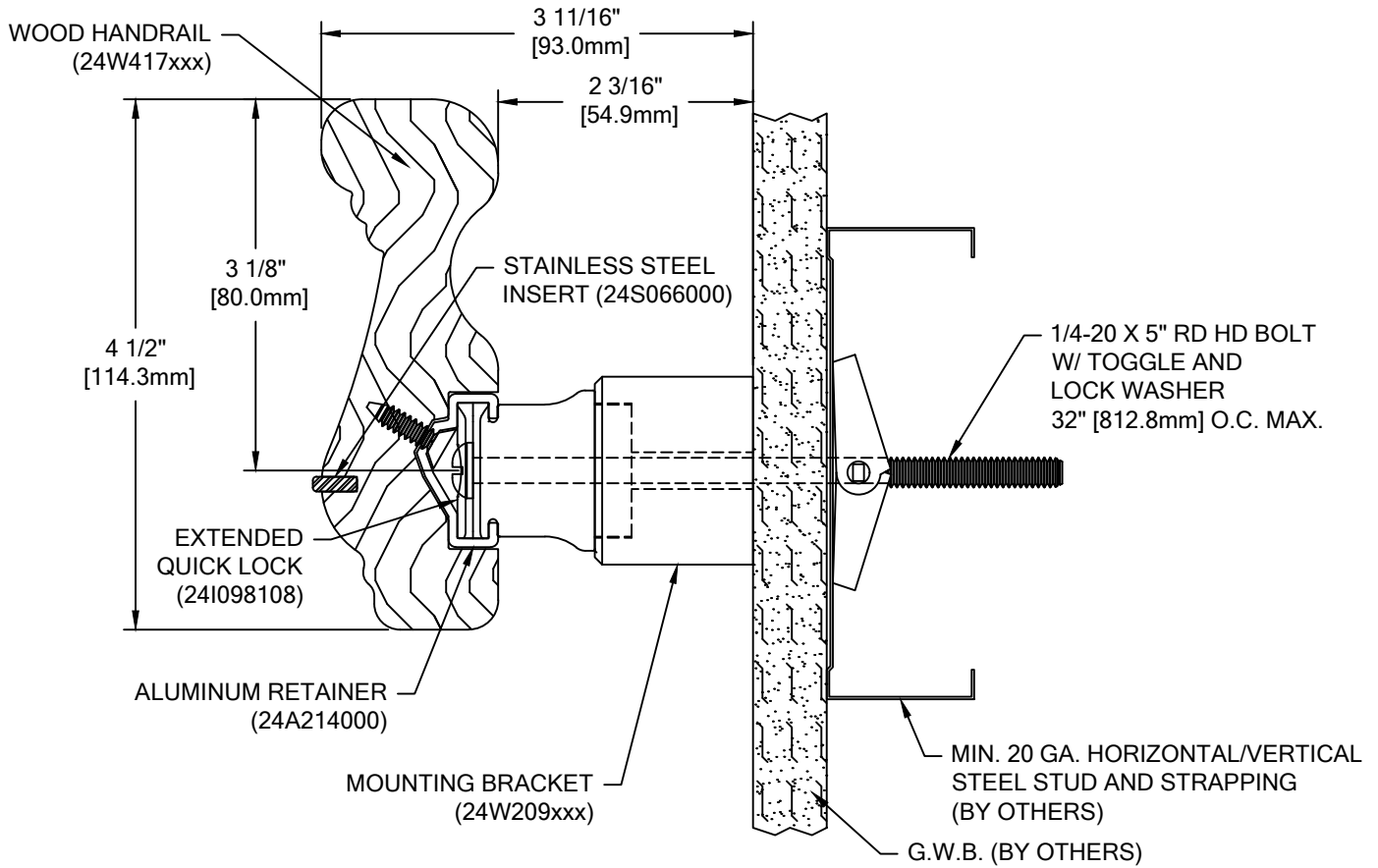

HRW-45S

INTERNATIONAL OFFSET

WALL CONDITION	SPECIFIED FASTENER	DRILL DIAMETERS		CS PART NUMBER
		WALL	RETAINER	
STEEL STUD/GYPSUM WALL	1/4-20 X 5" ROUND HEAD BOLT WITH TOGGLE, AND LOCK WASHER	3/4"	9/32"	90H049002 90H006003
CONCRETE/CONCRETE BLOCK	#14 X 5" S/S PHILLIPS RD HD ALL-PURPOSE SCREW	3/16"	9/32"	90H287006
WOOD STUD/GYPSUM WALL	#14 X 5" S/S PHILLIPS RD HD ALL-PURPOSE SCREW	1/8"	9/32"	90H287006

 Hughesville, PA 800.233.8493 570.546.5941 Mississauga, ON 888.895.8955 905.274.3611 www.c-sgroup.com © Copyright 2017 Construction Specialties, Inc.	PROJECT:	REVISION:
	JOB NO.:	F&F:
	CUSTOMER:	
	REP:	DATE:
	DRAWN BY:	SHEET NO: