

FB-22

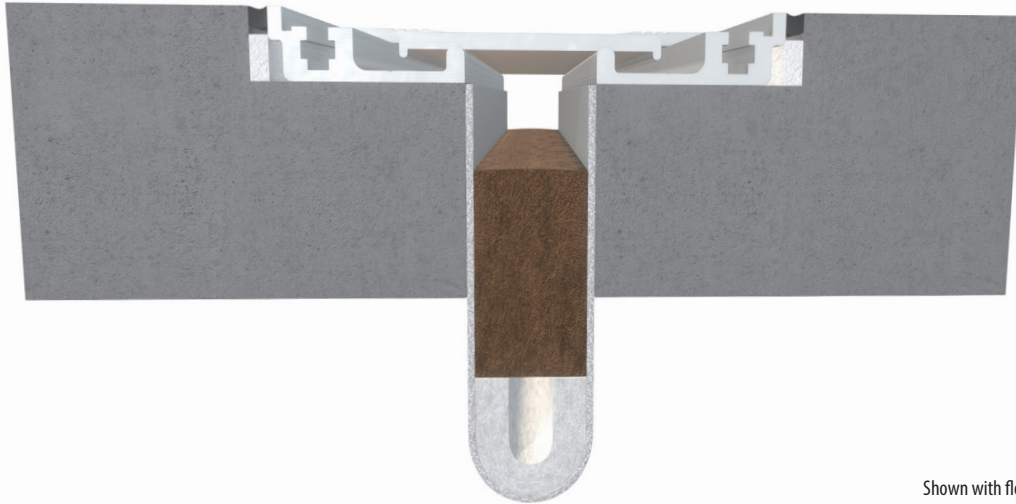

Shown with floor cover (sold separately)

This fire barrier is designed for 1" - 4" floor expansion joints. Our third-party listing ensures a 2-hour rating for 1" - 4" joints and up to 3-hour rating for 1" - 2" joints. This blanket type fire barrier accommodates dynamic movement without degradation of the material. FB-22 does not have any mechanical fasteners and has a simple splice method which reduces installation time.

Product Details

- For 1" - 4" (25.4mm - 101.6mm) nominal floor joints
- 25' (7.6m) stock lengths
- In Stock - 25 LF per box
- Transitions easily to FB-24 wall fire barrier
- Standard Five-Year Warranty

Certifications

- Performance Standards: UL-2079, ASTM E1399
- Code Compliance: UBC, SBC, BOCA, IBC

Applications

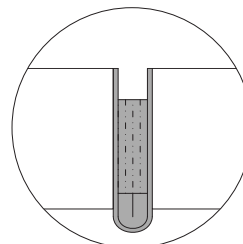

1" - 2" Floor

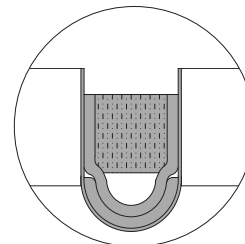

3" - 4" Floor



Additional resources

FB-22



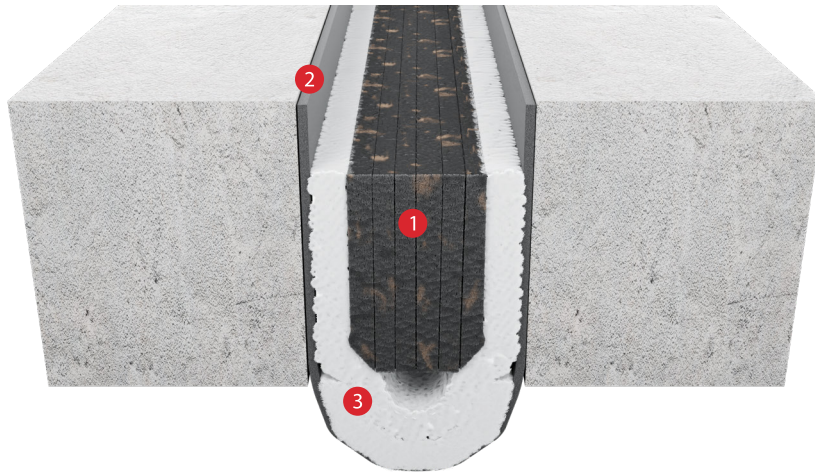

 Buy Online

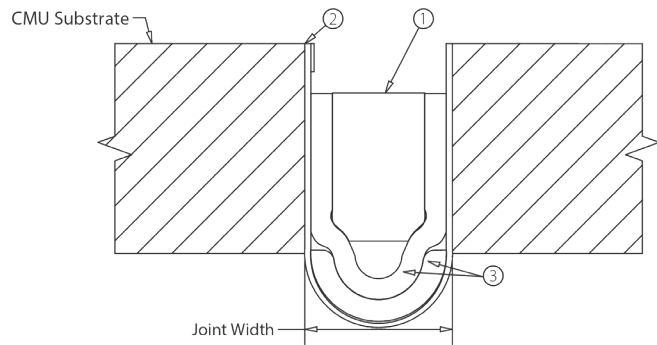

- 1. Insulation block
- 2. Ceramic paper
- 3. Ceramic blanket



Performance Data

MODEL NUMBER	JOINT WIDTH	MIN. OPENING	MAX. OPENING	FIRE RATING	LISTING NUMBER
 23FB22F1PK1	1.00" (25.4mm)	0.50" (12.7mm)	1.50" (38.1mm)	2HR/3HR	CSI/EJCA 120-04
 23FB22F2PK1	2.00" (50.8mm)	1.00" (25.4mm)	3.00" (76.2mm)	2HR/3HR	CSI/EJCA 180-02
 2FB22F3PK1	3.00" (76.2mm)	1.50" (38.1mm)	4.50" (114.3mm)	2HR	CSI/EJCA 120-04
 2FB22F4PK1	4.00" (101.6mm)	2.00" (50.8mm)	6.00" (152.4mm)	2HR	CSI/EJCA 120-04

FB-22

Technical Details

- Block type barrier designed for 6" (maximum open) wall expansion joints.
- Provides a 2-hour wall fire endurance rating, minimizing smoke passage and accommodates dynamic movement without degradation of the material.
- Tested and listed by a third party for 2 or 3-hour floor applications (model specific)
- Basic Uses
 - For 6" (maximum open) vertical wall rated expansion joints for buildings and parking decks.
- Precautions
 - Refer to Material Safety Data Sheet for detailed health and safety information prior to use.