

ATTENTION

Please read these instructions thoroughly prior to beginning the **HB-200W50** installation!

This instruction sheet is intended to provide a specific guide to follow for the installation of the **HB-200W50**. Contained within is the technical information and installation techniques required to complete an efficient, neat, and long-lasting installation.

See "**Industrial Bumper and Corner Guard**– Supplemental Information" sheet for additional notes and other helpful installation tips.

Minimum length of **HB-200W50** is 6" [152.4mm] and requires at least 4 fasteners per unit.

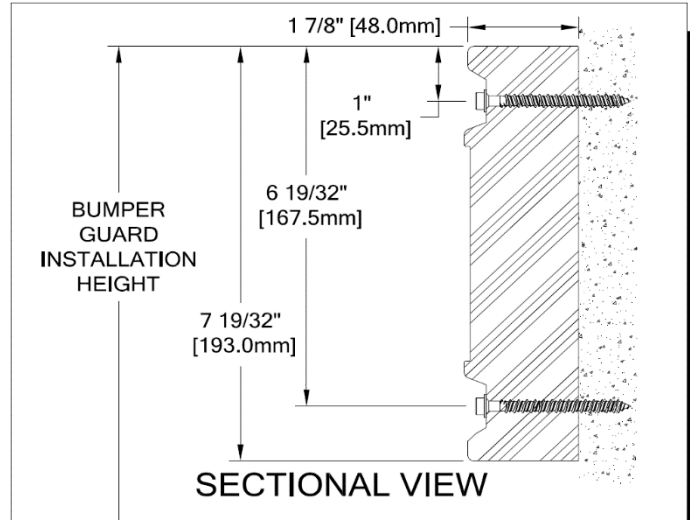

Parts List

1. HB-200W50 Industrial Bumper (24N027000)
2. Optional Reflective Tape (90M186003)
3. Specified Fasteners

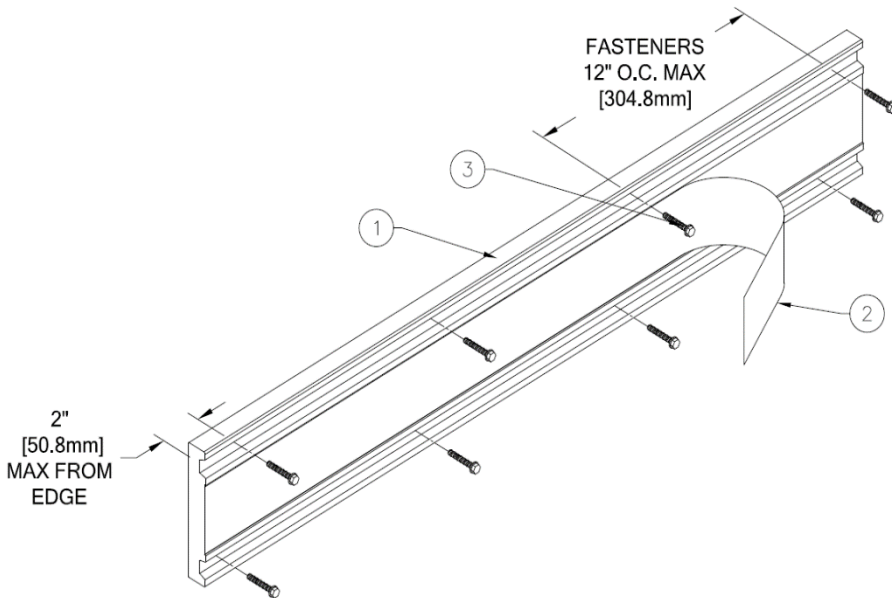

INSTALLATION INSTRUCTIONS

1. Establish bumper guard height above finish floor. Deduct 1" [25.0mm] and 6 19/32" [167.5mm] and snap a chalk line at that height. This marks the centerline location of the fasteners for the bumper guard.
2. Measure the area of the wall in which the bumper guard will be installed and cut the bumper guards unit to length.

Note: Bumper guard at inside and outside corners are to be field mitered.

3. Drill clearance holes in the guard 2" [50.8mm] max from each end of the unit and then 12" [304.8mm] max on center with top and bottom fasteners being staggered. Reference chart below for correct drill diameter.
4. Using the guard as a template, mark the fastener locations on the wall then pre-drill wall for specified fasteners. Use the chart below for drill hole diameters.
5. Install the bumper guard unit using the specified fasteners being careful not to overtighten. Use a level to insure the bumper guards is level.

NOTE: For walls that require more than (1) piece of bumper guard, multiple bumper guards can be butted together during installation.

NOTE: If the bumper guard gets the optional reflective tape, see below for installation.

6. Once the bumper guard is on the wall, clean product of any obvious dirty marks using mild detergent and water.

OPTIONAL REFLECTIVE TAPE INSTALLATION

1. Once bumper is on the wall, wipe the middle of the bumper down using denatured alcohol. Let bumper dry.
2. After the bumper is dry, apply the tape starting at one end of the industrial bumper.
3. Using a small paint roller with a foam roller, attach the tape over the entire desired length of the industrial bumper. The paint roller will help to smooth out any air bubbles while attaching the tape.
4. Once the tape is on the industrial bumper, clean product of any obvious dirty marks using mild detergent and water.

WALL CONDITION	SPECIFIED FASTENER	DRILL DIAMETER		CS PART NUMBER
		WALL	BUMPER	
Concrete / Concrete Block	1/4" x 2-3/4" Hex Washer Head Tapcon	3/16"	5/16"	90H941002
Steel Stud and Gypsum Wall Brd	1/4" x 5" Round Head Toggle Bolt with Toggle Wing	3/4"	9/32"	90H049002
Wood Stud and Gypsum Wall Brd	#14 X 4" Phillips Round Head All Purpose Screw	7/32"	9/32"	90H225002

Hughesville, PA | 800.233.8493 | 570.546.5941
 Mississauga, ON | 888.895.8955 | 905.274.3611

www.c-sgroup.com
IWPTechSupport@c-sgroup.com