

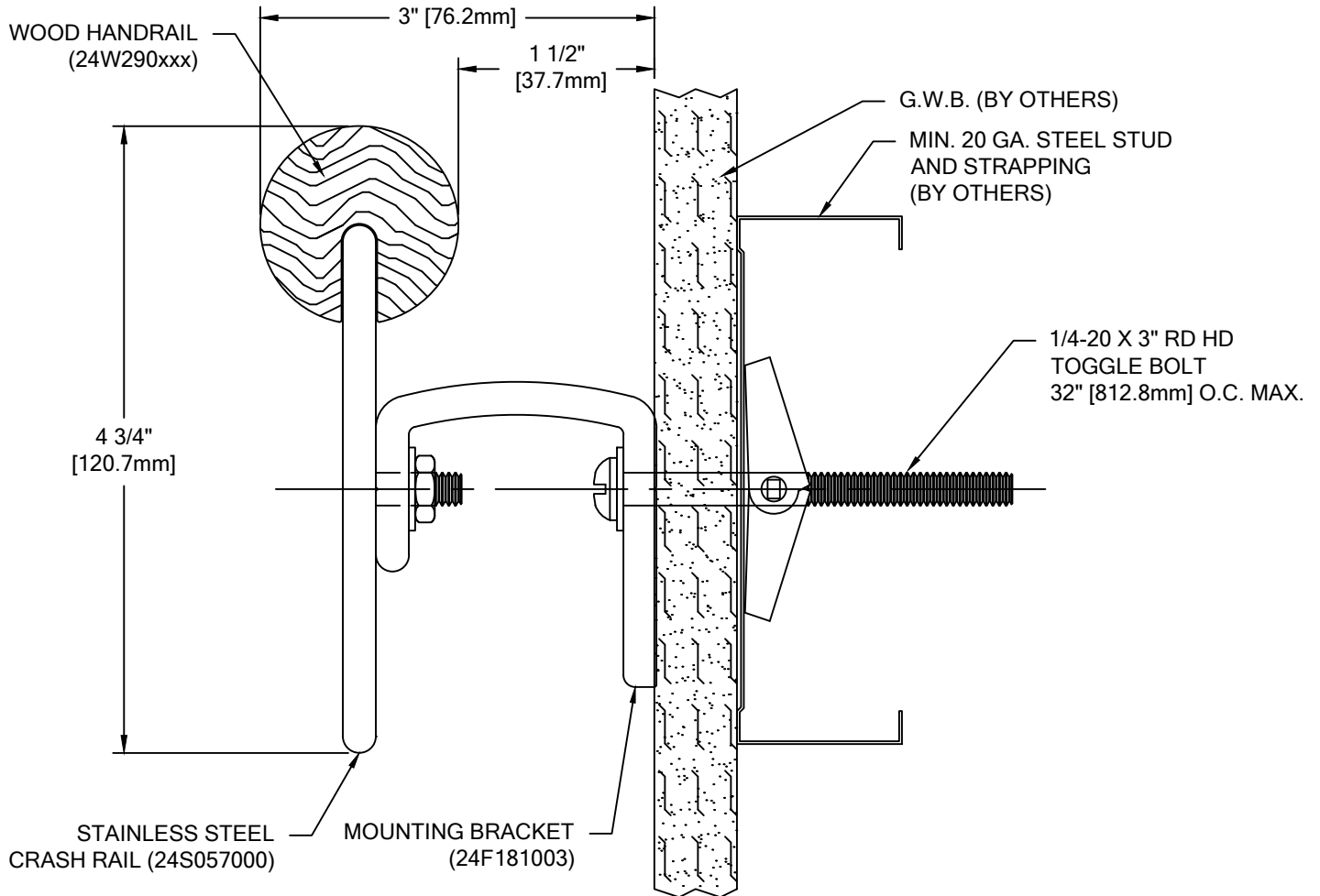

COLOR: \_\_\_\_\_  
 HANDRAIL WOOD SPECIES: \_\_\_\_\_  
 HANDRAIL WOOD FINISH: \_\_\_\_\_  
 COLOR TO BE SELECTED FROM ONE OF C/S STANDARD COLORS.

TOTAL L/F REQ'D	LEFT END CAPS	RIGHT END CAPS	O.S.C. REQ'D	I.S.C. REQ'D



# HRW-32S

WALL CONDITION	SPECIFIED FASTENER	DRILL DIAMETERS		C/S PART NUMBER
		WALL	RETAINER	
STEEL STUD/GYPSUM WALL	1/4-20 X 3" ROUND HEAD BOLT/TOGGLE WING	3/4"	N/A	90H045002
CONCRETE/CONCRETE BLOCK	#14 X 4" PHILLIPS ROUND HEAD ALL-PURPOSE SCREW	7/32"	N/A	90H225002
WOOD STUD/GYPSUM WALL	#14 X 4" PHILLIPS ROUND HEAD ALL-PURPOSE SCREW	7/32"	N/A	90H225002

 <p><b>Construction Specialties™</b>          6696 Route 405 Highway, Muncy PA 17756          (800) 233-8493 • Fax (570) 546-4692 • www.c-sgroup.com</p>	<b>PROJECT:</b>	<b>REVISION:</b>
	<b>JOB NO.:</b>	<b>F&amp;F:</b>
	<b>CUSTOMER:</b>	
	<b>REP:</b>	<b>DATE:</b>
	<b>DRAWN BY:</b>	<b>SHEET NO:</b>