

## FRWS-1 FEATURE RAIL

### PLEASE READ

PLEASE READ THESE INSTRUCTIONS THOROUGHLY PRIOR TO BEGINNING THE FRWS-1 FEATURE RAIL INSTALLATION!

THIS INSTRUCTION SHEET IS INTENDED TO PROVIDE A SPECIFIC GUIDE TO FOLLOW FOR THE INSTALLATION OF THIS FRWS-1 FEATURE RAIL. CONTAINED WITHIN IS THE TECHNICAL INFORMATION AND INSTALLATION TECHNIQUES REQUIRED TO COMPLETE AN EFFICIENT, NEAT AND LONG-LASTING INSTALLATION.

INSPECT ALL MATERIALS FOR DAMAGE OR MISSING PARTS. IF YOU DISCOVER DAMAGED OR MISSING MATERIALS, IN THE USA PLEASE NOTIFY THE FACTORY AT (800) 233-8493, AND IN CANADA (888) 895-8955 FOR CUSTOMER SERVICE.

FRWS-1 FEATURE RAIL MUST BE INSTALLED IN ACCORDANCE WITH THESE INSTRUCTIONS! FAILURE TO FOLLOW THESE INSTRUCTIONS MAY VOID ANY PRODUCT WARRANTIES AND RESULT IN AN UNSUCCESSFUL INSTALLATION. FOR SPECIFIC QUESTIONS REGARDING THE INSTALLATION OF THIS FRWS-1 FEATURE RAIL PLEASE CALL THE FACTORY IN THE USA AT (800) 233-8493 OR EMAIL IWPTECHSUPPORT@C-SGROUP.COM. IN CANADA CALL (888) 895-8955.

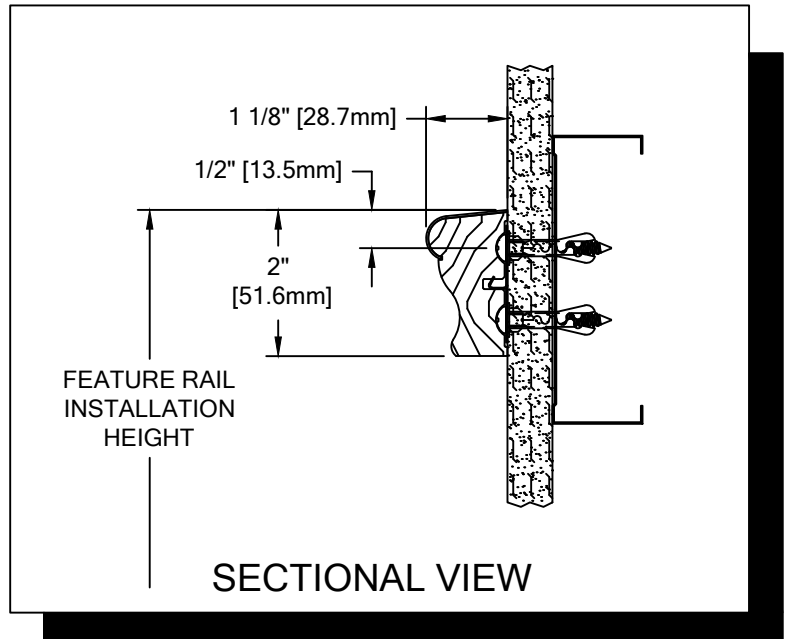

### IMPORTANT NOTES

1. THIS MATERIAL HAS BEEN MANUFACTURED TO CUSTOMER SPECIFIED DIMENSIONS AND CAN NOT BE CUT OR MODIFIED ON SITE. TO DO SO COULD VOID THE WARRANTY.
2. ALL DIMENSIONS ARE TYPICAL.
3. FOR DRYWALL/PLASTER WALL CONSTRUCTION, IT IS RECOMMENDED FOR FASTENERS TO BE ENGAGED INTO METAL/WOOD STUDS TO MAINTAIN MAXIMUM PULLOUT STRENGTH. IF DURING INSTALLATION YOU ENCOUNTER SPECIAL WALL CONDITIONS THAT DO NOT ALLOW FOR DIRECT ATTACHMENT TO THE STUDS PLEASE CONSULT THE LOCAL AUTHORITY HAVING JURISDICTION.
4. AF-6 PLASTIC ANCHORS SHOULD SEAT FLUSH WITH GYPSUM WALL.
5. MATERIAL MUST REACH 65°F MIN. TO 75°F MAX. 24 HOURS PRIOR TO INSTALLATION. THIS IS ESSENTIAL TO MINIMIZE EXPANSION AND CONTRACTION.
6. FEATURE RAIL SPLICE SHOULD NOT EXCEED 4" [101.6mm] DISTANCE FROM A WALL MOUNT CLIP.
7. THIS RAIL REQUIRES A MINIMUM OF 2 MOUNTING BRACKETS PER UNIT. THE MINIMUM END CAP-TO-END CAP CRASH RAIL LENGTH IS 4 1/2" [114.3mm].
8. FOR MORE INFORMATION ON FRWS-1 FEATURE RAIL SEE OUR WEBSITE AT [www.c-sgroup.com](http://www.c-sgroup.com).

**FRWS-1 FEATURE RAIL**
COMPONENTS & WALL FASTENERS



WOOD FEATURE RAIL  
(24W375xxx)



FRWS-1 STAINLESS  
STEEL COVER  
(24S254000)

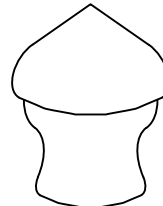

STAINLESS STEEL END CAP  
(24S239000, LH)  
(24S388000, RH)



OPTIONAL WOOD END CAP  
(24W376xxx, LH)  
(24W377xxx, RH)

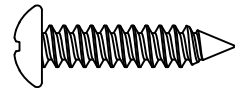

FASTENER #1  
#12 X 1" S/S PHILLIPS  
PAN HEAD SMS  
(90H716002)



ACCENT REVEAL  
(24F220004)

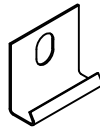

RETAINER CLIP  
(24M050000)

WALL CONDITION	SPECIFIED FASTENER	DRILL DIAMETERS		CS PART NUMBER
		WALL	RETAINER	
STEEL STUD/GYPSUM WALL	#10 x 1 1/2" PHILLIPS PAN HEAD SMS AF-6 PLASTIC ANCHORS	1/4"	9/32"	90H189002 90H039004
CONCRETE/CONCRETE BLOCK	#10 x 1 1/2" PHILLIPS PAN HEAD SMS AF-6 PLASTIC ANCHORS	1/4"	9/32"	90H189002 90H039004
WOOD STUD/GYPSUM WALL	#10 x 2-1/4" PHILLIPS PAN HEAD SMS	N/A	N/A	90H421008
20 GA. MIN. STEEL STUD AND 20 GA. MIN. STEEL STRAPPING / GYPSUM WALL CONSTRUCTION REQUIRED (TEK SCREWS)	#6 PHILLIPS PAN HEAD BUGLE HEAD TEK SCREW	N/A	N/A	90H079002

FRWS-1 FEATURE RAIL

LAYOUT VIEW

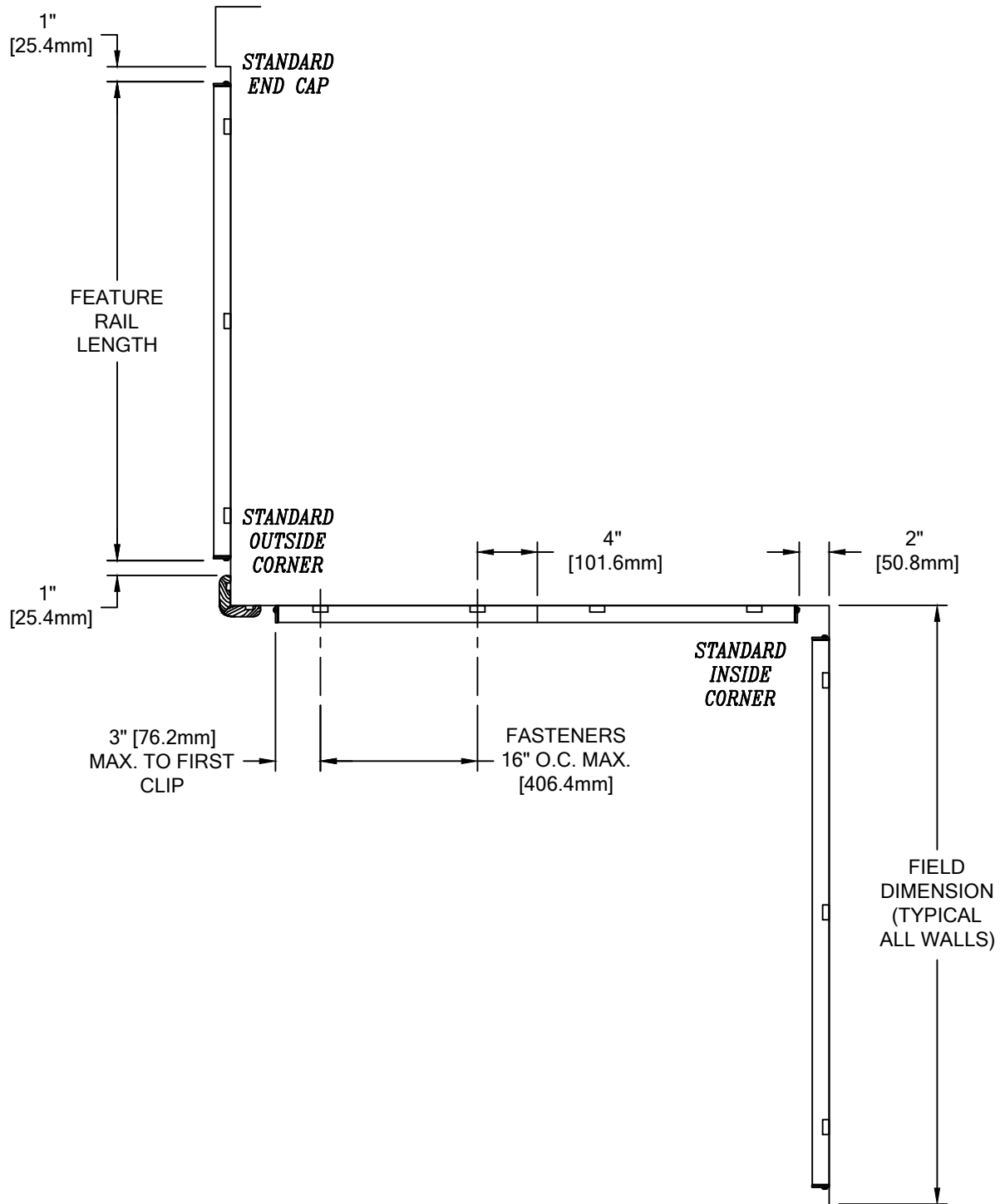

**FRWS-1 FEATURE RAIL**

TYPICAL ASSEMBLY

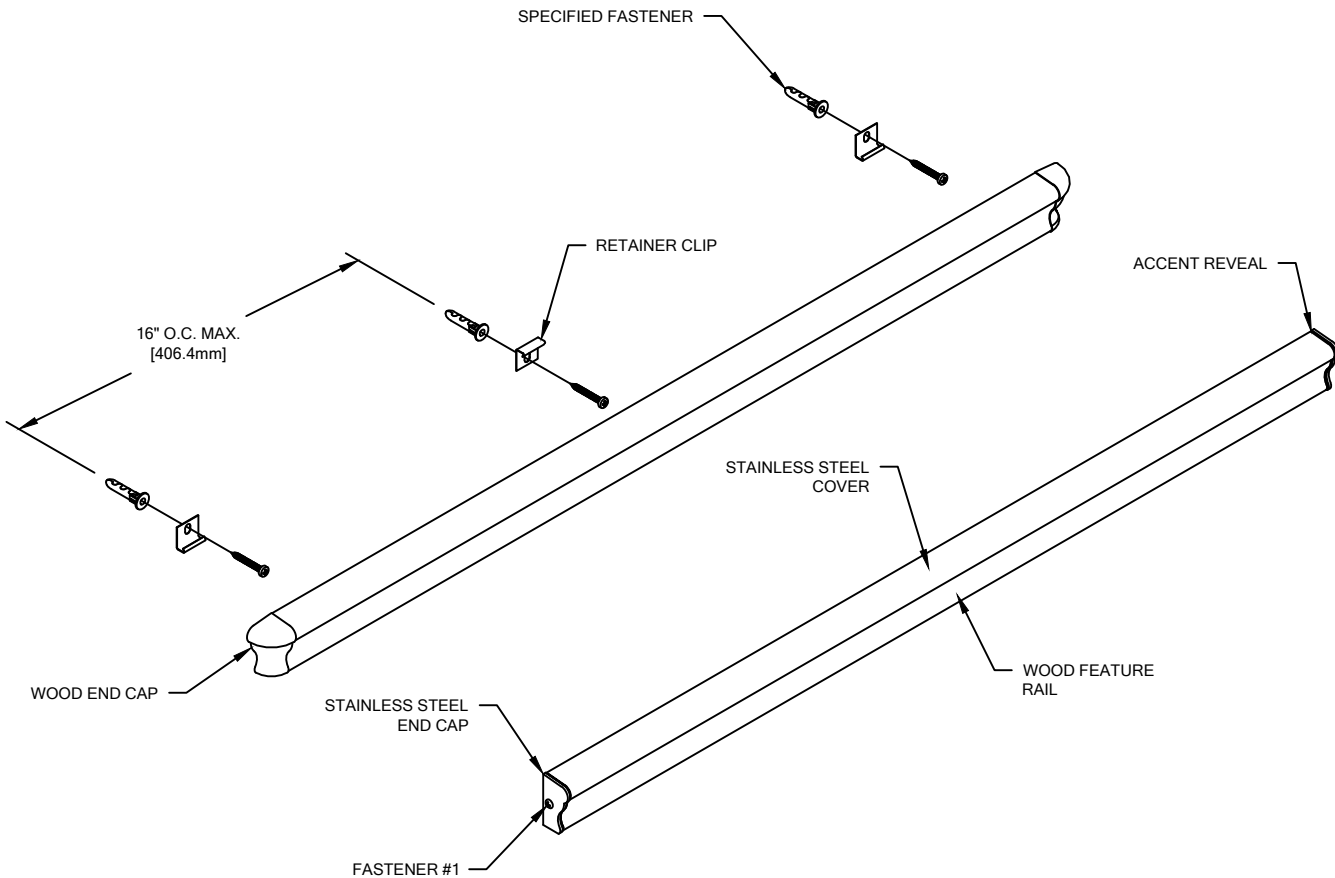

1. ESTABLISH FEATURE RAIL HEIGHT ABOVE FINISH FLOOR. FROM THE TOP EDGE OF THE FEATURE RAIL DEDUCT 1/2" [12.7mm] AND 1" [25.4mm] AND SNAP A CHALK LINE AT THESE HEIGHTS. THIS MARKS THE LOCATION OF THE FASTENERS FOR THE RETAINER CLIPS.
2. DETERMINE WALL FASTENER LOCATIONS BY USING THE REQUIRED DEDUCTIONS (SEE LAYOUT VIEW) AND DRILL HOLE DIAMETER IN THE WALL FOR SPECIFIED WALL FASTENERS. REFERENCE CHART ON PAGE 2 FOR CORRECT DRILL DIAMETERS.
3. INSTALL EACH RETAINER CLIP ONTO THE WALL (ALTERNATING UP AND DOWN, NOTE THE CLIP ORIENTATION ABOVE), IN SUCCESSION, USING THE APPROPRIATE FASTENERS. USE A LEVEL TO ENSURE RETAINER CLIPS ARE LEVEL.

**WARNING:** BE SURE RETAINER CLIPS AND FEATURE RAIL ARE IN CORRECT LOCATION. ONCE FEATURE RAIL IS INSTALLED, IT WILL BE DIFFICULT TO REMOVE WITHOUT DAMAGING FEATURE RAIL, WALL AND/OR RETAINER CLIPS.

4. TO INSTALL FEATURE RAIL, BEGIN CLIPPING FEATURE RAIL TO WALL AT ONE END AND WORK YOUR WAY DOWN THE LENGTH OF THE RAIL. USE A SOFT RUBBER Mallet TO TAP THE FACE AT CLIP LOCATIONS TO SEAT THE FEATURE RAIL ONTO THE RETAINER CLIPS. BE CAREFUL NOT TO DAMAGE THE FEATURE RAIL. SEE SECTIONAL VIEW FOR ALIGNMENT. THOROUGHLY CLEAN FEATURE RAIL UPON COMPLETION OF INSTALLATION.