

MODEL RFB-200 THRU 400 & RFBWB-200 THRU 400 INSTALLATION INSTRUCTIONS

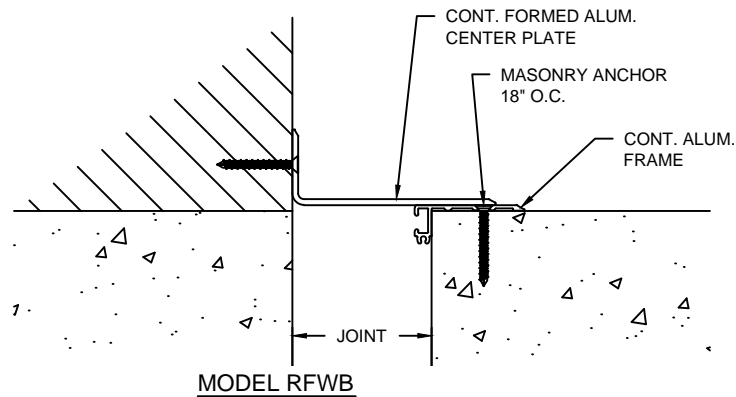
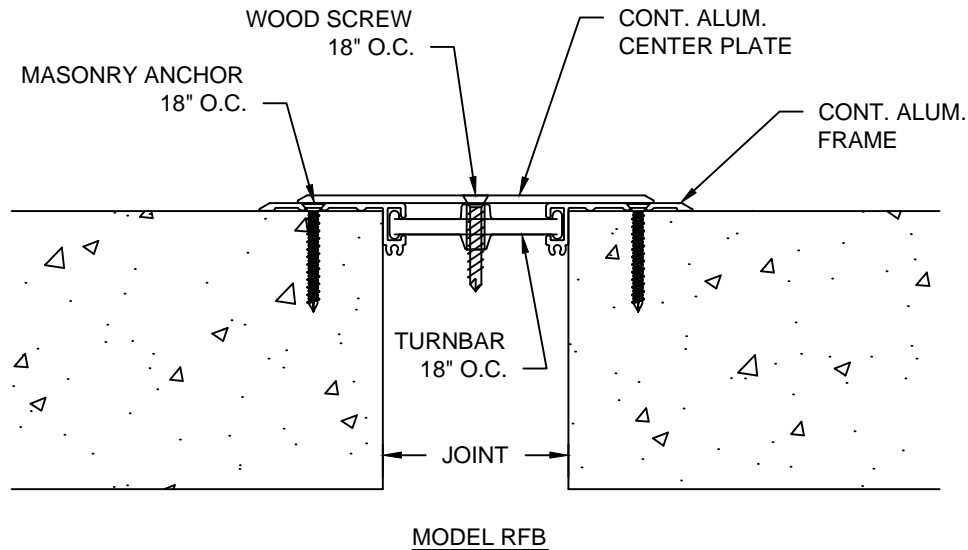

IMPORTANT INFORMATION

Prior to the commencement of installation, all materials **MUST** be inspected for damage. Any damage must be reported to CONSTRUCTION SPECIALTIES, INC., as soon as possible, so that replacement materials may be furnished without delay.

All work must be completed as per Architect's Approved "Shop Drawings", and in accordance with these Installation Instructions. When installation is complete, all materials must be protected from damage until the Architect's FINAL INSPECTION.

All materials should be arranged in the order that they are to be installed. All hardware required for each portion of the work should be placed with the appropriate materials.

Please review all Approved Shop Drawings and this document to familiarize yourself with all the details and components of this assembly.

IMPORTANT:

READ THROUGH ALL INSTRUCTIONS PRIOR TO STARTING INSTALLATION

8/26/13



Construction Specialties™

6696 Route 405 Highway, Muncy PA 17756
(800) 233-8493 • Fax (570) 546-5169 • www.c-sgroup.com

This document is the property of Construction Specialties, Inc. and contains CONFIDENTIAL PROPRIETARY INFORMATION that is not to be disclosed to third parties and is not to be used without approval in writing from Construction Specialties, Inc.

Notes

Before beginning installation, review the architectural drawings and approved Construction Specialties Inc. shop drawings to familiarize yourself with the joint cover models and locations.

Check all of the joint cover components to confirm that the correct joint cover model and size have been received. Also, check for materials that may have been damaged during shipping. Report all incorrect and/or damaged components to C/S at 800-233-8493.

Read through all the steps of these instructions prior to beginning work.

STEP 1

PREPARE FLOOR SLAB

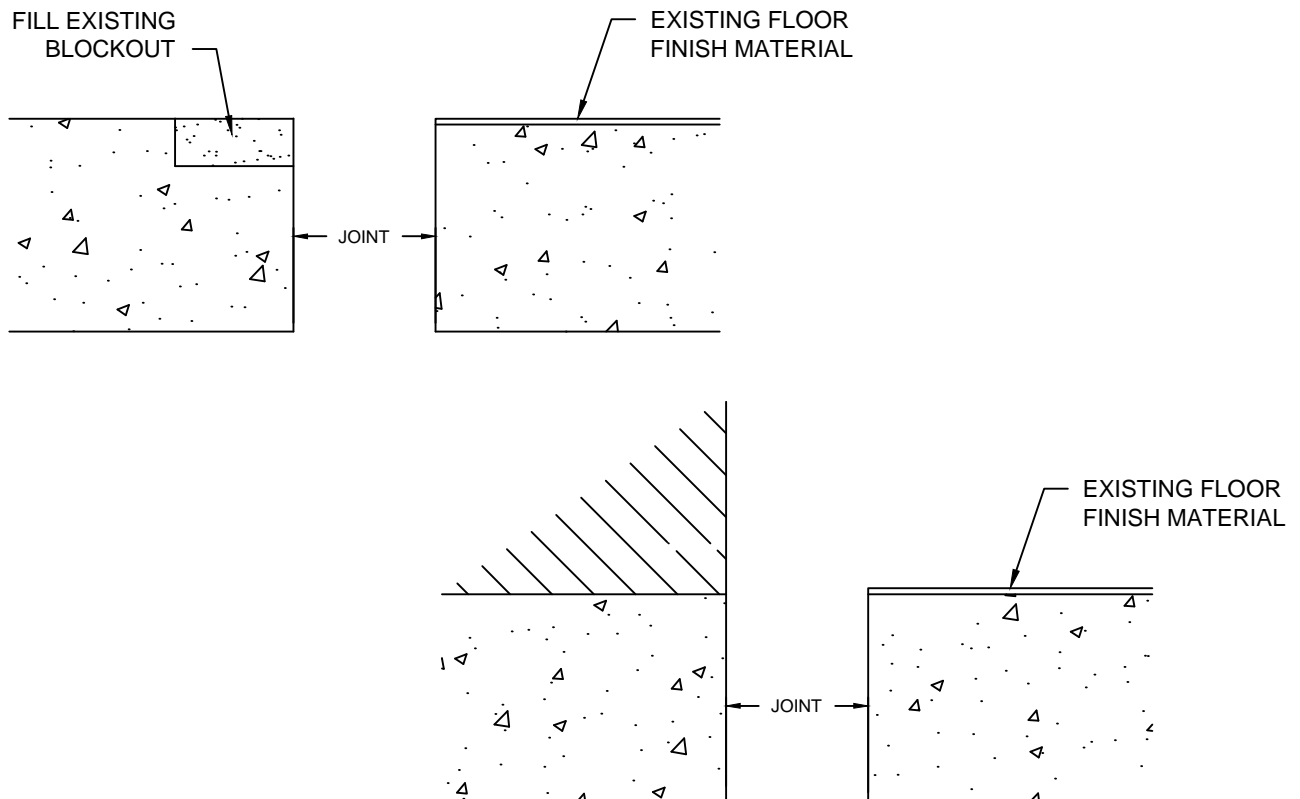

RFB/RFWB MODELS	
MODEL	JOINT DIM.
RFB-200, RFWB-200	2" [50.80mm]
RFB-300, RFWB-300	3" [76.20mm]
RFB-400, RFWB-400	4" [101.60mm]

Step 1:

1.1) Where necessary, prepare the floor slab for installation of the joint cover:

- Fill any existing joint cover blockout to level and smooth.
- RFB joint covers can be mounted over existing floor finish materials or direct to concrete slab.

STEP 2

FRAME INSTALLATION

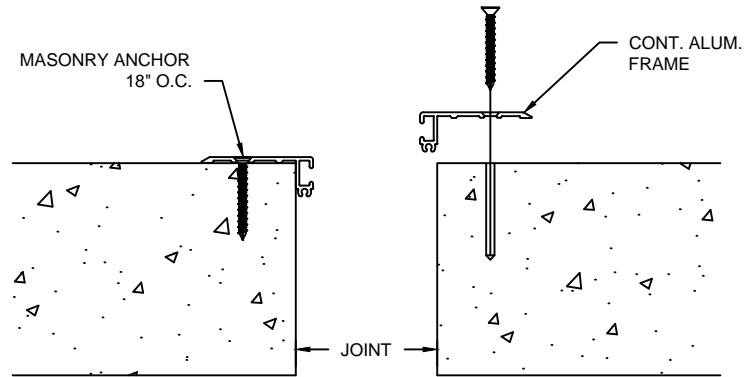

MODEL RFB

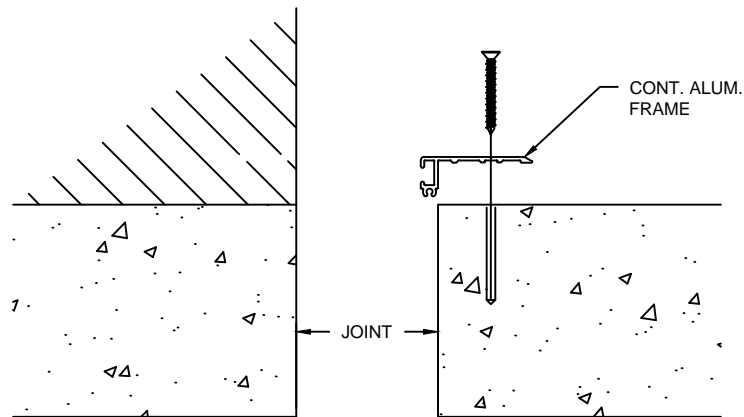

MODEL RFWB

Note:

- If a C/S Fire Barrier is to be installed in the joint, please review the Fire Barrier Installation Instructions supplied, and if required install the Fire Barrier **BEFORE** installation of C/S Expansion Joint Cover Aluminum Frames.
- If a Vapor Barrier/Waterstop is to be installed in the joint, please review the Vapor Barrier/Waterstop Installation Instructions supplied, and if required install the Vapor Barrier/Waterstop **BEFORE** installation of C/S Seismic Expansion Joint Aluminum Frames.
- If there is an expected temperature change of 20°F(+) daily, leave a 1/16" gap between Frames for 10' sections or an 1/8" gap between Frames for a 20' section due the thermal expansion of aluminum. Caulk (by others) in between Frames to seal gap.

Step 2:

2.1) Begin installation of the Frames by placing a length of Frame onto the floor slab at one end of the run. If necessary, cut the Frame to length as needed. The Frame is to sit level and flat. In floor-to-floor applications (RFB) the Frames on opposite sides of the joint must be parallel. Adjust as needed for uneven joint edges.

2.2) Using the Frame as a template, drill holes for the C/S supplied anchor bolts per manufacturer's guidelines.

2.3) Anchor the Frame to the slab using the C/S supplied anchor bolts following the manufacturer's guidelines.

Before proceeding with installation of additional Frame lengths if needed, insert Turnbars as indicated in Step 3.

STEP 3

TURNBAR INSTALLATION

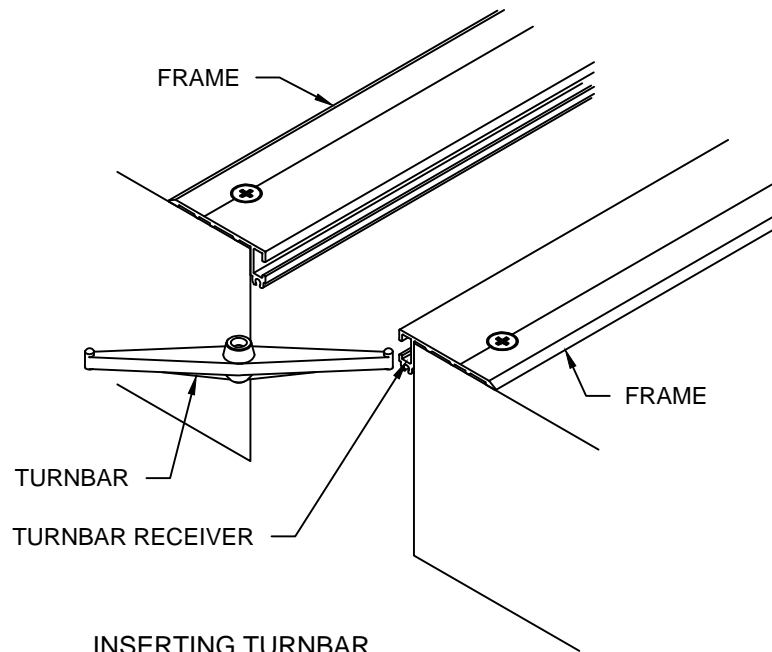

INSERTING TURNBAR

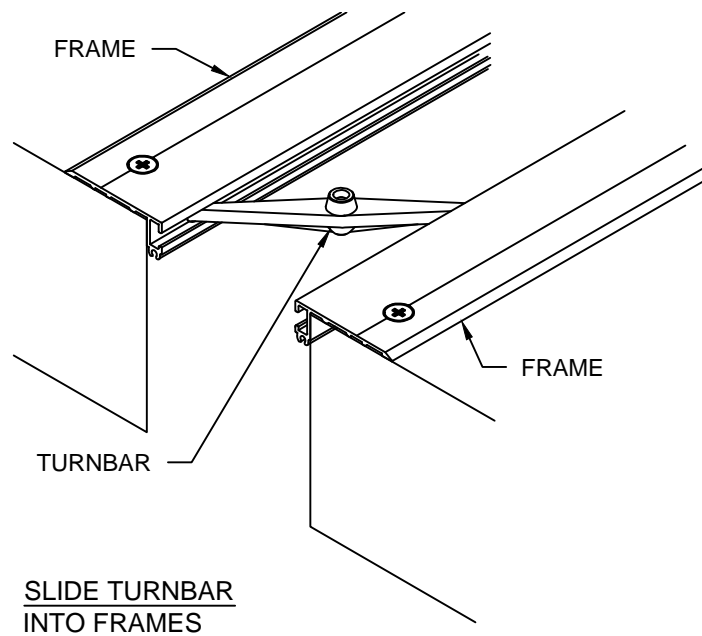

SLIDE TURNBAR INTO FRAMES

Step 3:

3.1) Begin installation of the Turnbars by determining the number of Turnbars needed for the length of the run. There are (7) required for each 10' length of cover plate or (14) for each 20' run of Frames. For cut lengths, Turnbars are to be 6" in from the end and 18" o.c..

3.2) Slide the Turnbars into the Turnbar receivers of the Frames (see detail above) and space at approx. 18" centers.

Notes: The orientation of the Turnbars should all be the same direction or the system will not function. Please note the orientation of the Turnbars in the details above (the side with the part number on it faces up). Floor-to wall models (RFWB) do not require any Turnbars.

STEP 4

ADDITIONAL FRAME INSTALLATION

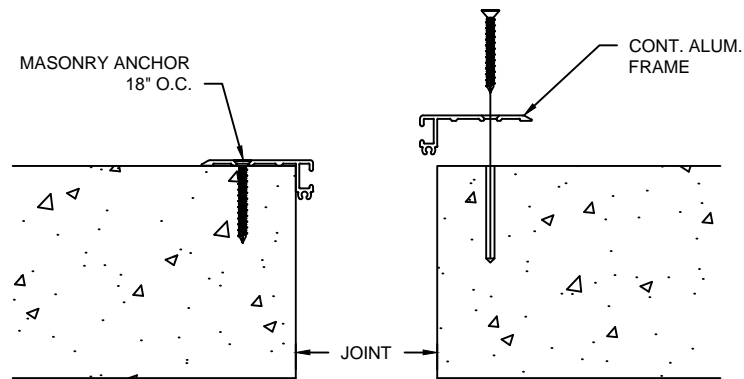

MODEL RFB

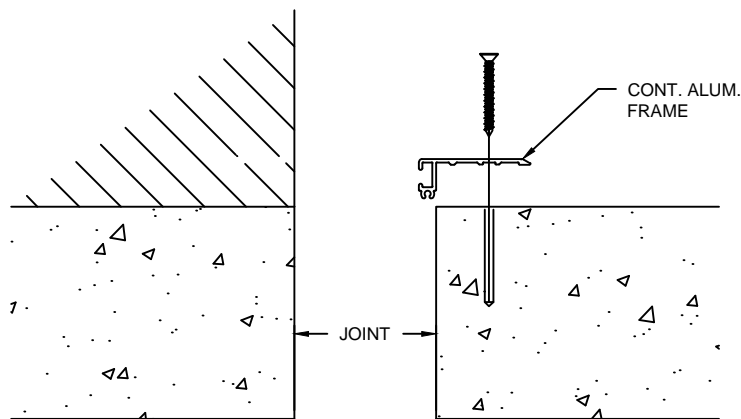

MODEL RFWB

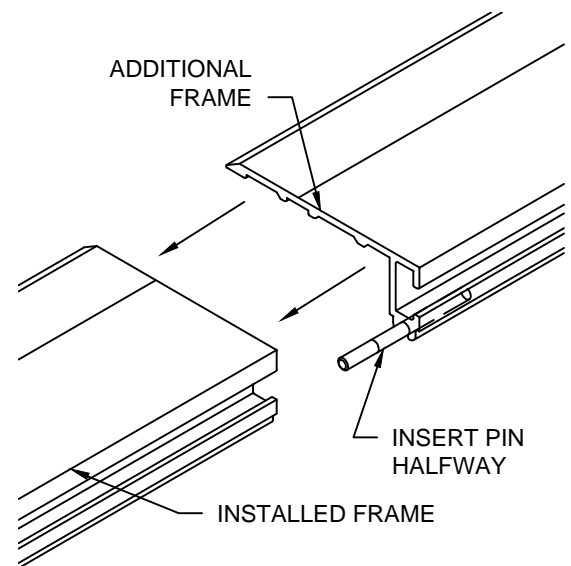

FRAME ALIGNMENT

4.1) Repeat the Step 2 installation procedure for any additional lengths of Frame.

4.2) For additional lengths of Frame, insert the grooved end of the Alignment Pin, approximately half of its length, into the alignment slots of the Additional Frame.

4.3) Align the loose Frame with the previously installed Frame and slide together. Make sure the Alignment Pins slide into the slots of the previously installed Frame.

4.4) At the end of the run, measure mark and cut Frames to the required length and install as instructed.

Note: Insert Turnbars with each pair of Frames as indicated in Step 3. At the end of the run, insert the Turnbars into the Frames before anchoring the Frames to the floor slabs.

STEP 5

COVER PLATE INSTALLATION

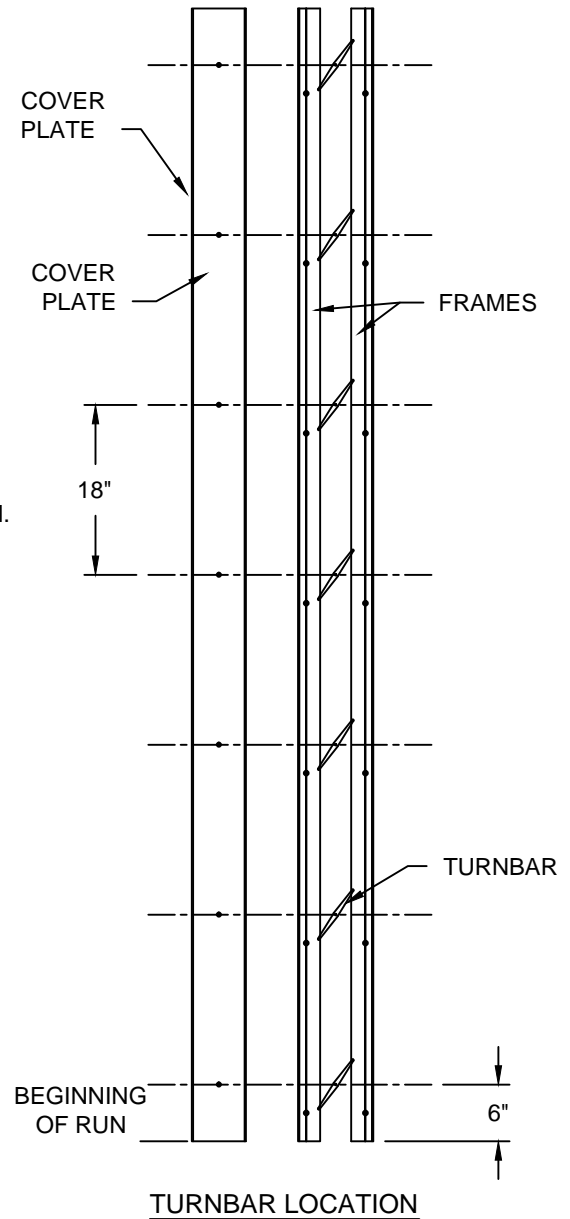
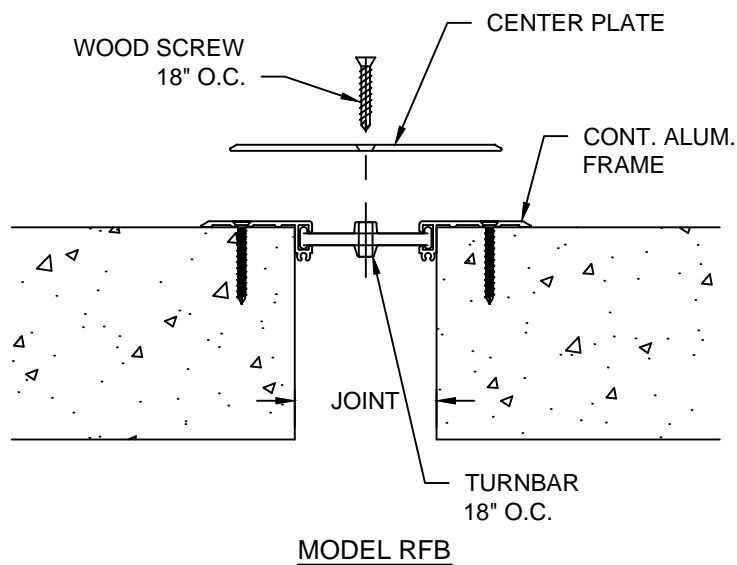

Step 5:

IMPORTANT NOTE: Over tightening of the Wood screw into the Turnbars may cause Turnbars to break. It is important to follow these instructions.

5.1) Begin installation of the Cover Plate by first placing a length of the Cover Plate beside the joint and aligned with the end of the run. Cut the plate to length if needed.

5.2) Slide the previously installed Turnbars along the frames and align a Turnbar with each hole in the Cover Plate.

5.3) Place the Cover Plate over the joint/Frames. Make sure that the holes of the Cover Plate and Turnbars are aligned. If needed, shine a light into the holes and use a piece of wire to align the Turnbars with the holes.

5.4) Using the C/S supplied wood screws attach the Center Plate to the Turnbars. **DO NOT FULLY TIGHTEN.**

5.5.) Once all of the wood screws have been partially fastened, go back through and tighten until the head of the screw is flush with the top of the Center Plate plus an additional 1/4 turn.

5.6) For additional lengths of Center Plate, repeat Steps 5.1 through 5.5.

STEP 6

COVER PLATE INSTALLATION

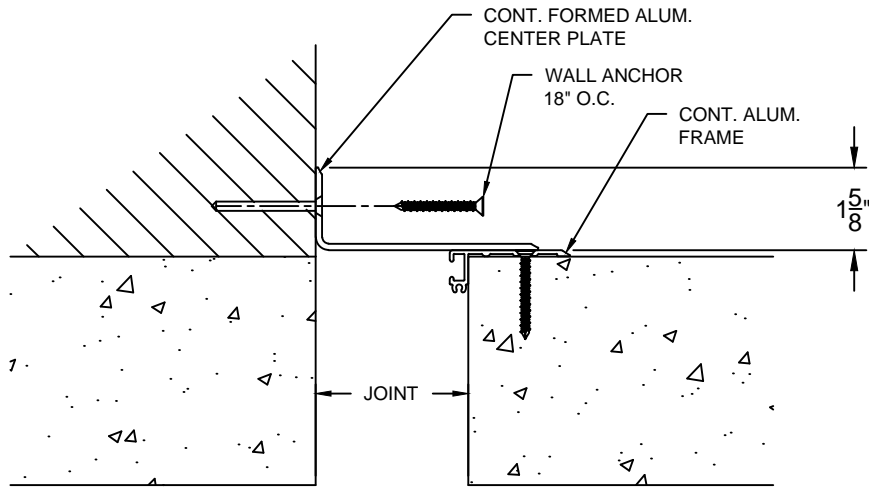

MODEL RFWB

Floor to Wall Applications:

- 6.1) Place the first length of Formed Cover on top of the Frame and against the face of the wall. The top edge of the Cover plate should be a 1 5/8" above the top of slab..
- 6.2) Using the Center Plate as a template, mark and drill the location for the C/S supplied wall fasteners. Note: The type of anchor will vary with the wall substrate.
- 6.3) Attached the Center Plate using the C/S supplied wall fasteners in accordance with the manufacturer's guidelines.
- 6.4) Repeat these installation instructions for any additional lengths of Formed Center Plate.

STEP 7

COMPLETE INSTALLATION

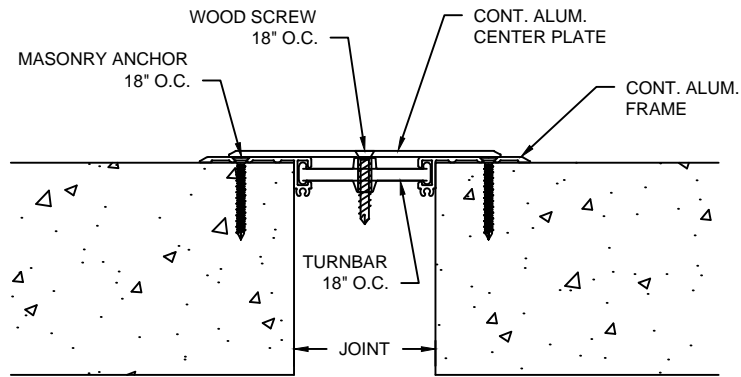

MODEL RFB

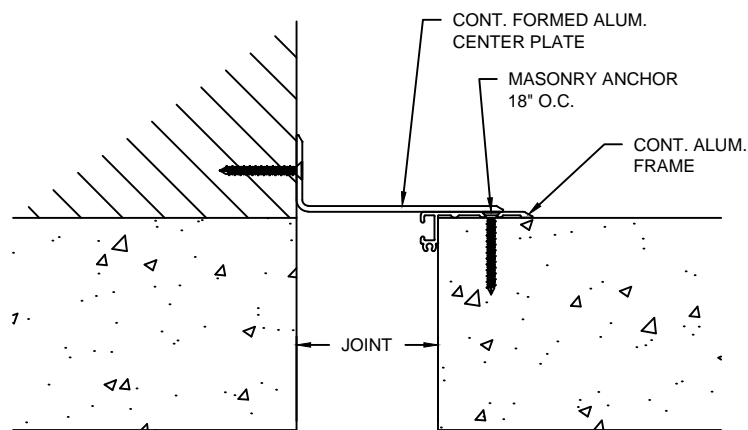

MODEL RFWB

Step 7:

- 7.1) When installation of the C/S Floor Expansion Joint Cover has been completed, remove all residue and foreign matter from the area and joint cover.
- 7.2) Clean the C/S Joint Cover and adjoining surfaces with appropriate cleaners.
- 7.3) Protect the Joint Cover until the Architect's final inspection.