

PEDIMAT AA WITH RECESSED TAPERED ANGLE FRAME



INSERT STYLE:

INSERT COLOR: PLEASE ADVISE

CATALOG NUMBER: M2

PART NUMBER:

|     |             |      |    |
|-----|-------------|------|----|
| NO. | REVISION    | DATE | BY |
| NO. | F&F RELEASE | DATE | BY |

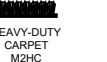
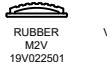
|   |   |  |  |  |  |  |
|---|---|--|--|--|--|--|
| <br>RECYCLED RUBBER<br>M2RR<br>19R005XXX | <br>EXTERIOR CARPET<br>M2EC<br>19C018XXX | <br>HEAVY-DUTY CARPET<br>M2HC<br>19C010XXX<br>19C022XXX | <br>RUBBER<br>M2V<br>19V022501<br>#8501 BLACK | <br>VINYL ABRASIVE<br>M2VA<br>19A007XXX<br>19M001XXX | <br>SERRATED ALUM. INSERT<br>M2SAI<br>19A001001 | <br>POURED ABRASIVE INSERT<br>M2PA<br>19A005XXX |
|---|---|--|--|--|--|--|

PEDIMAT AA INSERT STYLES

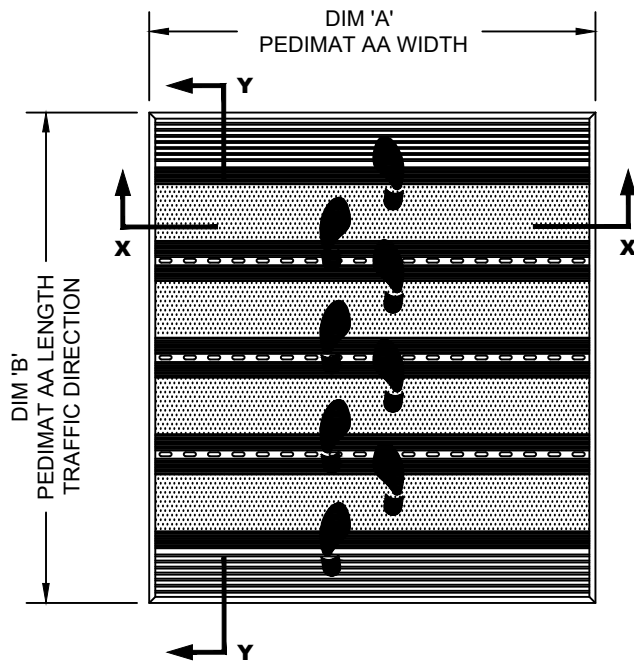

SQUARE END VINYL  
1" (25.4mm) WIDE (17V013XXX)  
2" (50.8mm) WIDE (17V014XXX)

ALUMINUM TAPERED  
ANGLE FRAME  
(16A051XXX)

FEMALE PEDIMAT AA  
RAIL (17A002XXX)

DIM 'B'  
PEDIMAT AA LENGTH  
TRAFFIC DIRECTION

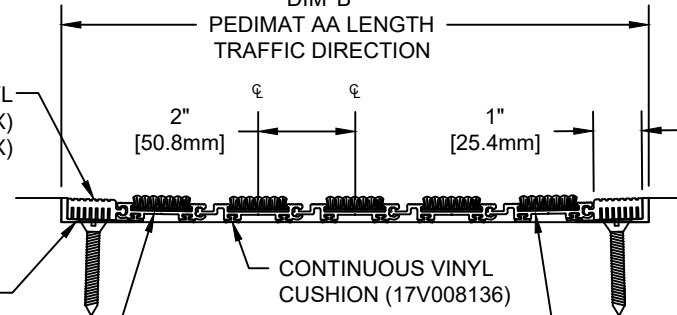

SECTION Y-Y

MALE / FEMALE  
PEDIMAT AA  
RAIL (17A001XXX)

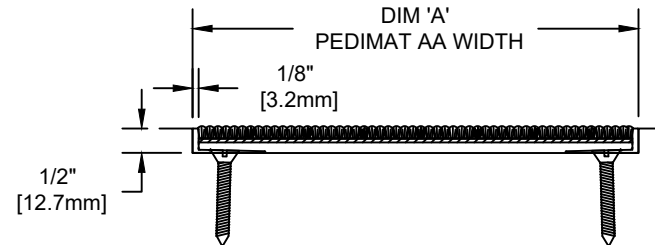

SECTION X-X

3/16" MASONRY  
LAG FASTENER  
(90H066004)  
24" (609.6mm) O.C.

NOTES:

\*ALL SURFACES IN CONTACT WITH MASONRY ARE TO RECEIVE A COAT OF ZINC CHROMATE PRIMER

\*MAX. SINGLE GRID SIZE NOT TO EXCEED 12'-0" (3.66M) IN WIDTH (DIM "A") OR 100 SQUARE FEET

\*PLEASE VERIFY TRAFFIC DIRECTION

\*PEDIMAT AA SHALL BE ABLE TO SUPPORT A 350 LB. ROLLING LOAD. LARGER LOADING MAY BE ACCOMMODATED. CONTACT C/S SALES WITH SPECIFIC LOADING REQUIREMENTS.

\*ADDITIONAL SPECIFICATIONS ARE CONTAINED IN THE LATEST C/S CATALOG OR AT C-SGROUP.COM AND ARE CONSIDERED PART OF THIS TRANSMITTAL.

**CS Construction Specialties**  
6696 Route 405 Highway, Muncy PA 17756  
(800) 233-8493 • Fax (570) 546-4692 • www.c-sgroup.com

| PLEASE VERIFY ALL | QTY | MARK # | LOCATION | MODEL | DIM 'A' WIDTH | DIM 'B' LENGTH | FINISH | NOTES |
|-------------------|-----|--------|----------|-------|---------------|----------------|--------|-------|
|                   |     |        |          |       |               |                |        |       |
|                   |     |        |          |       |               |                |        |       |
|                   |     |        |          |       |               |                |        |       |
|                   |     |        |          |       |               |                |        |       |

|             |       |          |
|-------------|-------|----------|
| PROJECT:    |       |          |
| LOCATION:   |       |          |
| CONTRACTOR: |       |          |
| AGENT:      |       | SHT:     |
| DRG. BY:    | DATE: | JOB NO.: |