

SGR-S & SGRW-S Series

Technical Data:

Aluminum

- Extrusion – CS uses multiple alloys & tempers which are established to be the most appropriate for the given use of individual parts. Will be one of the following: (6063-T5, T6, T52) (6061-T5, T6, T51) (6105-T5, T6) (6005-T5) (6005A-T5, T61), ASTM B221
- Sheet – 6061-T6, 3003-H14, 5005-H34, ASTM B209

Stainless Steel

- Type 304 ASTM A167, A240A, A240M

Primary Seal

- Dual Durometer 65 Shore A, 90 Shore A, ASTM D2240.
- Available in 4 Standard colors

Premium Color

- Platinum

Turnbar

- Material – C1075 Blue Temper Spring Steel
- Hardness – RC 44-47
- Finish – “A” Coating (Corrosion Protection)

Standard Loading

- 500 lbs.

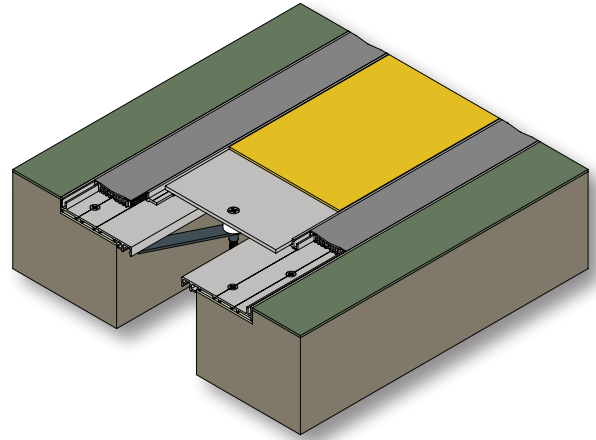

SGR-S & SGRW-S Series

MODEL	JOINT WIDTH	MINIMUM OPENING	MAXIMUM OPENING	EXPOSED SURFACE	BLOCKOUT WIDTH	BLOCKOUT HEIGHT
SGR-500S/B	5.00" (127mm)	2.75" (70mm)	9.25" (235mm)	12.00" (305mm)	3.50" (89mm)	0.75" (19mm)
SGR-600S/B	6.00" (152mm)	2.75" (70mm)	9.25" (235mm)	13.00" (330mm)	3.50" (89mm)	0.75" (19mm)
SGR-700S/B	7.00" (178mm)	2.75" (70mm)	12.25" (311mm)	15.00" (381mm)	4.00" (102mm)	0.75" (19mm)
SGR-800S/B	8.00" (203mm)	2.75" (70mm)	13.25" (337mm)	16.00" (406mm)	4.00" (102mm)	0.75" (19mm)
SGR-900S/B	9.00" (229mm)	2.75" (70mm)	14.13" (359mm)	18.00" (457mm)	4.50" (114mm)	0.75" (19mm)
SGR-1000S/B	10.00" (254mm)	2.75" (70mm)	16.25" (413mm)	19.00" (483mm)	4.50" (114mm)	0.75" (19mm)
SGR-1100S/B	11.00" (279mm)	2.75" (70mm)	18.13" (461mm)	21.00" (533mm)	5.00" (127mm)	0.75" (19mm)
SGR-1200S/B	12.00" (305mm)	2.75" (70mm)	18.38" (467mm)	22.00" (559mm)	5.00" (127mm)	0.75" (19mm)
SGR-1300S/B	13.00" (330mm)	2.75" (70mm)	21.25" (540mm)	24.00" (610mm)	5.50" (140mm)	0.75" (19mm)
SGR-1400S/B	14.00" (356mm)	2.75" (70mm)	22.25" (565mm)	25.00" (635mm)	5.50" (140mm)	0.75" (19mm)
SGR-1500S/B	15.00" (381mm)	2.75" (70mm)	22.75" (578mm)	27.00" (686mm)	6.00" (152mm)	0.75" (19mm)
SGR-1600S/B	16.00" (406mm)	2.75" (70mm)	25.25" (641mm)	28.00" (711mm)	6.00" (152mm)	0.75" (19mm)

Call factory for joints larger than 16"

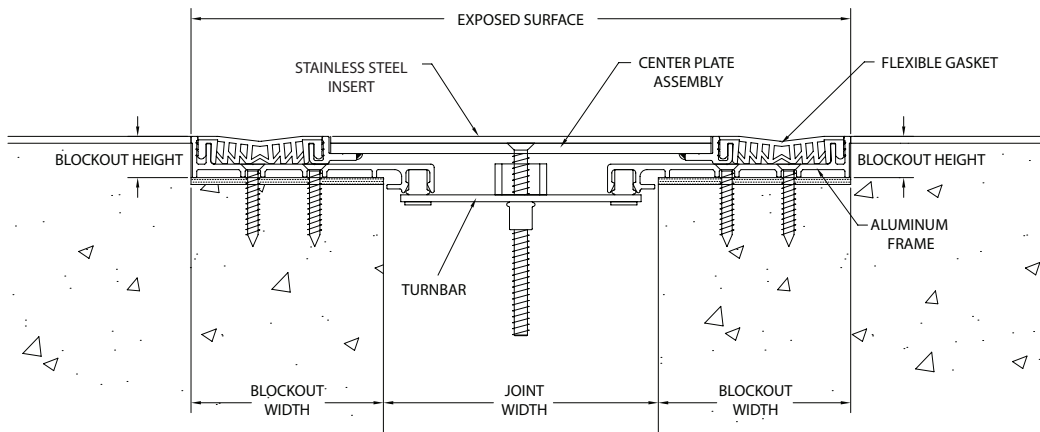

SGR-S

SGR-S & SGRW-S Series

MODEL	JOINT WIDTH	MINIMUM OPENING	MAXIMUM OPENING	EXPOSED SURFACE	BLOCKOUT WIDTH	BLOCKOUT HEIGHT
SGRW-500S/B	5.00" (127mm)	3.56" (90mm)	6.56" (167mm)	8.50" (216mm)	3.50" (89mm)	0.75" (19mm)
SGRW-600S/B	6.00" (152mm)	4.06" (103mm)	7.75" (197mm)	9.50" (241mm)	3.50" (89mm)	0.75" (19mm)
SGRW-700S/B	7.00" (178mm)	4.94" (125mm)	9.69" (246mm)	11.00" (279mm)	4.00" (102mm)	0.75" (19mm)
SGRW-800S/B	8.00" (203mm)	5.44" (138mm)	10.63" (270mm)	12.00" (305mm)	4.00" (102mm)	0.75" (19mm)
SGRW-900S/B	9.00" (229mm)	5.94" (151mm)	11.56" (294mm)	13.50" (343mm)	4.50" (114mm)	0.75" (19mm)
SGRW-1000S/B	10.00" (254mm)	6.44" (164mm)	13.13" (334mm)	14.50" (368mm)	4.50" (114mm)	0.75" (19mm)
SGRW-1100S/B	11.00" (279mm)	6.94" (176mm)	14.63" (372mm)	16.00" (406mm)	5.00" (127mm)	0.75" (19mm)
SGRW-1200S/B	12.00" (305mm)	7.44" (189mm)	15.25" (387mm)	17.00" (432mm)	5.00" (127mm)	0.75" (19mm)
SGRW-1300S/B	13.00" (330mm)	7.94" (202mm)	17.13" (435mm)	18.50" (470mm)	5.50" (140mm)	0.75" (19mm)
SGRW-1400S/B	14.00" (356mm)	8.44" (214mm)	18.13" (461mm)	19.50" (495mm)	5.50" (140mm)	0.75" (19mm)
SGRW-1500S/B	15.00" (381mm)	8.94" (227mm)	18.75" (476mm)	21.00" (533mm)	6.00" (152mm)	0.75" (19mm)
SGRW-1600S/B	16.00" (406mm)	9.44" (240mm)	20.63" (524mm)	22.00" (559mm)	6.00" (152mm)	0.75" (19mm)

Call factory for joints larger than 16"

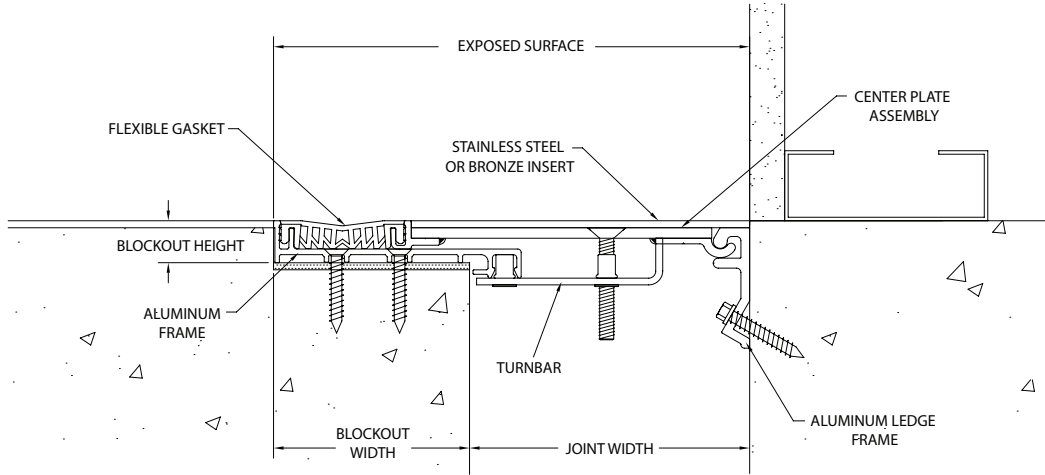

SGRW-S