

FR-451N FEATURE RAIL

PLEASE READ

PLEASE READ THESE INSTRUCTIONS THOROUGHLY PRIOR TO BEGINNING THE FR-451N FEATURE RAIL INSTALLATION!

THIS INSTRUCTION SHEET IS INTENDED TO PROVIDE A SPECIFIC GUIDE TO FOLLOW FOR THE INSTALLATION OF THIS FR-451N FEATURE RAIL. CONTAINED WITHIN IS THE TECHNICAL INFORMATION AND INSTALLATION TECHNIQUES REQUIRED TO COMPLETE AN EFFICIENT, NEAT AND LONG-LASTING INSTALLATION.

INSPECT ALL MATERIALS FOR DAMAGE OR MISSING PARTS. IF YOU DISCOVER DAMAGED OR MISSING MATERIALS, IN THE USA PLEASE NOTIFY THE FACTORY AT (800) 233-8493, AND IN CANADA (888) 895-8955 FOR CUSTOMER SERVICE.

FR-451N FEATURE RAIL MUST BE INSTALLED IN ACCORDANCE WITH THESE INSTRUCTIONS! FAILURE TO FOLLOW THESE INSTRUCTIONS MAY VOID ANY PRODUCT WARRANTIES AND RESULT IN AN UNSUCCESSFUL INSTALLATION. FOR SPECIFIC QUESTIONS REGARDING THE INSTALLATION OF THIS FR-451N FEATURE RAIL PLEASE CALL THE FACTORY IN THE USA AT (800) 233-8493 OR EMAIL IWPTECHSUPPORT@C-SGROUP.COM. IN CANADA CALL (888) 895-8955.

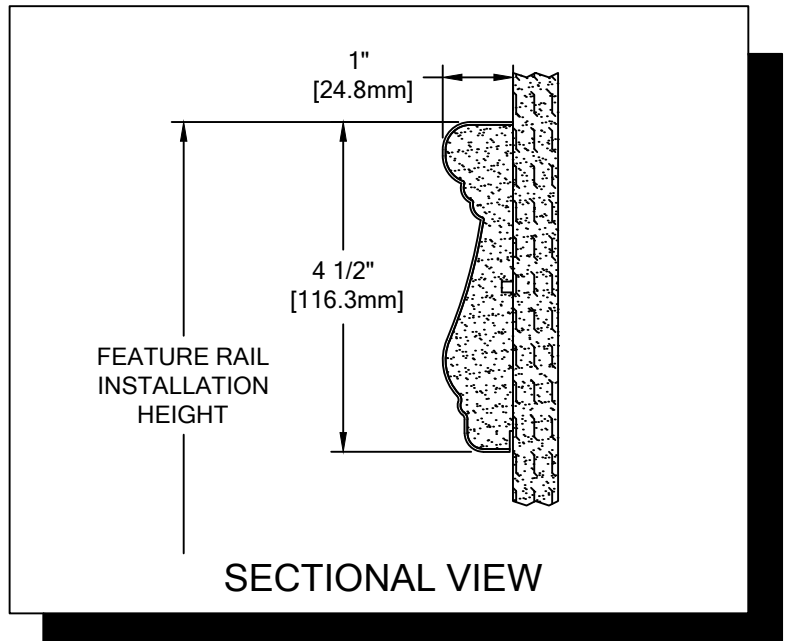

IMPORTANT NOTES

1. THIS FEATURE RAIL HAS BEEN SUPPLIED WITH A 1/4" WAINSCOT NOTCH TO ALLOW FOR MULTIPLE APPLICATIONS.
2. ALL ACROVYN MATERIAL TO BE SUPPLIED IN STOCK LENGTHS. THIS MATERIAL IS TO BE FIELD CUT USING QUALITY EQUIPMENT TO INSURE THAT ALL CUTS ARE SQUARE. WHEN CUTTING MATERIAL SECTIONS, CS RECOMMENDS USING AN 80-100 TOOTH CARBIDE TIPPED SAW BLADE OR EQUIVALENT, TO MINIMIZE CHIPPING AND MAINTAIN JOINT ALIGNMENT.
3. RADIAL MATERIAL MAY BE SUPPLIED FACTORY FORMED OR IN STRAIGHT LENGTHS FOR FIELD FORMING. CONSULT FACTORY FOR OPTIONS.
4. ALL WALL SURFACES MUST BE CLEAN, SMOOTH, DRY AND FREE OF ANY LOOSE PAINT OR ANY OTHER IRREGULARITIES WHICH WOULD PREVENT GOOD ADHESION.
5. ALL DIMENSIONS ARE TYPICAL.
6. MATERIAL MUST REACH 65°F MIN. TO 75°F MAX. 24 HOURS PRIOR TO INSTALLATION. THIS IS ESSENTIAL TO MINIMIZE EXPANSION AND CONTRACTION OF MATERIAL.
7. END CAPS AND INSIDE/OUTSIDE CORNERS ARE TO BE FIELD MITERED.
8. SPLICES ARE TO BE CUT AT A 45-DEGREE ANGLE AS SHOWN IN THESE INSTRUCTIONS.
9. THE MINIMUM END CAP-TO-END CAP RAIL LENGTH IS 4" [101.6mm].
10. FOR MORE INFORMATION ON FR-451N FEATURE RAIL SEE OUR WEBSITE AT www.c-sgroup.com.

FR-451N FEATURE RAIL

LAYOUT VIEW

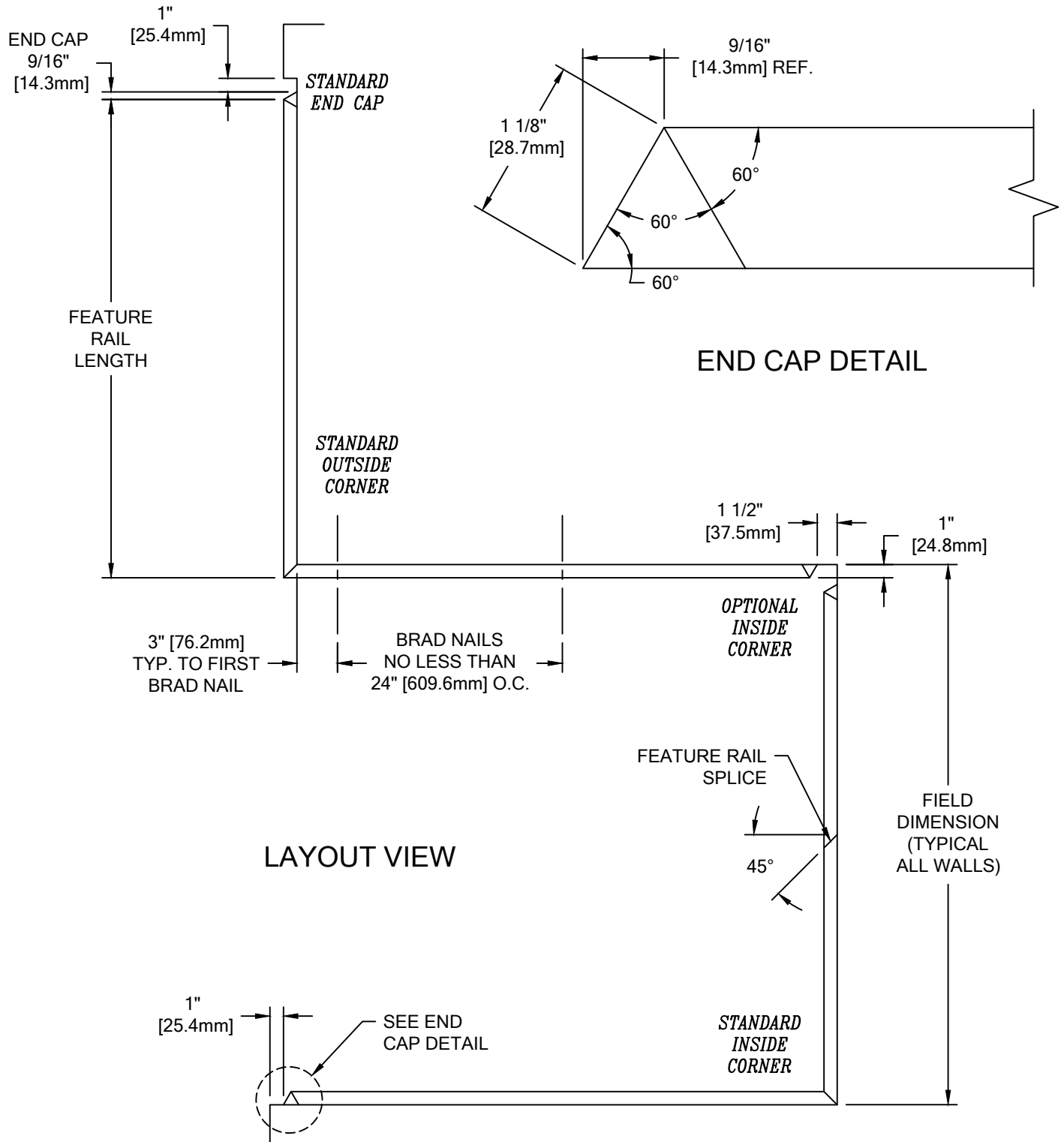

WALL CONDITION	SPECIFIED FASTENER	QUANTITY	CS PART NUMBER
STEEL STUD/GYPSUM WALL CONCRETE/CONC. BLOCK WOOD STUD/GYPSUM WALL	M1 STRUCTURAL ADHESIVE (85 L/F COVERAGE PER TUBE)	28 FL. OZ	90M135001

FR-451N FEATURE RAIL

TYPICAL ASSEMBLY

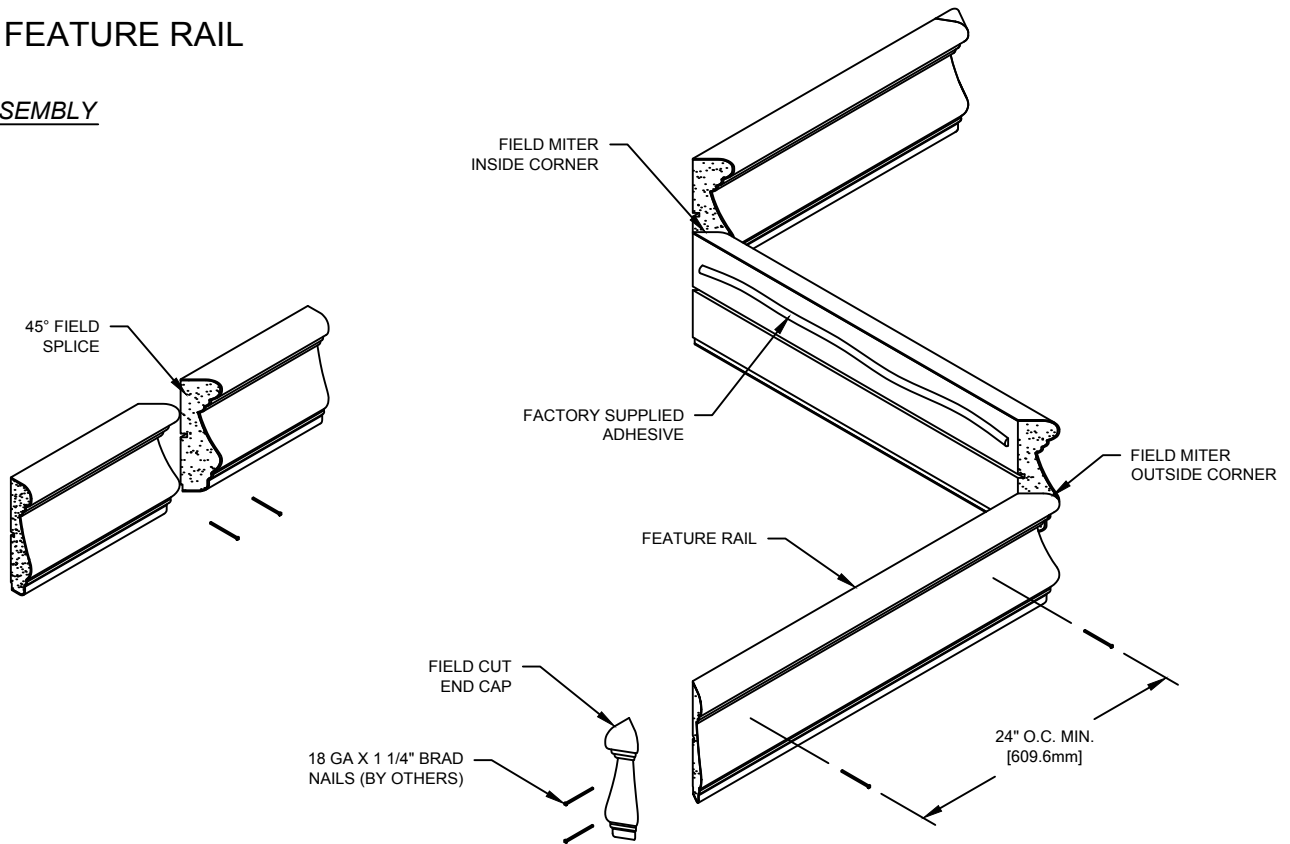

NOTE: INSTALLATION OF LINEAL OR RADIAL FR-451N FEATURE RAIL SHOULD BE DONE IN ACCORDANCE WITH THE FOLLOWING INSTRUCTIONS.

1. ALL WALL SURFACES MUST BE CLEAN, SMOOTH, DRY AND FREE OF ANY LOOSE PAINT OR ANY OTHER IRREGULARITIES WHICH WOULD PREVENT GOOD ADHESION.
2. ESTABLISH FEATURE RAIL HEIGHT ABOVE FINISH FLOOR. DEDUCT 4 1/2" [114.3mm] AND SNAP A CHALK LINE AT THE BOTTOM OF THE FEATURE RAIL TO BE USED AS A GUIDE FOR ALIGNING.
3. CUT ACROVYN FEATURE RAIL TO LENGTH (REFERENCE LAYOUT VIEW). ALL OUTSIDE AND INSIDE CORNERS ARE TO BE FIELD MITERED. ENDS THAT RECEIVE END CAPS ARE TO BE CUT AT A 60-DEGREE ANGLE (SEE END CAP DETAIL ON PAGE 2).

NOTE: IT IS RECOMMENDED THAT ACROVYN FEATURE RAIL BE CUT WITH AN 80-100 TOOTH CARBIDE TIPPED SAW BLADE OR EQUIVALENT.

4. DUE TO COLOR MATCH, END CAPS ARE TO BE CUT FROM THE SAME FEATURE RAIL SECTION. FIELD CUT THE END CAPS WITH 60-DEGREE CUTS ON BOTH ENDS. (SEE END CAP DETAIL ON PAGE 2)
5. ATTACH END CAPS TO THE FEATURE RAIL WITH WOOD GLUE (TITEBOND IS RECOMMENDED) AND TWO 18 GA X 1 1/4" BRAD NAILS. FEATURE RAILS THAT INTERSECT AT INSIDE/OUTSIDE CORNERS AND SPLICES ARE TO BE JOINED IN THE SAME MANNER. WIPE OFF ANY EXCESS GLUE. USE THE CS SUPPLIED COLOR MATCHED FIL-STICK TO HIDE THE BRAD NAILS.
6. MOUNT FEATURE RAIL TO THE WALL USING THE FACTORY SUPPLIED ADHESIVE. APPLY A 1/4" [6.4mm] BEAD OF ADHESIVE TO THE BACK SIDE OF THE RAIL. STARTING AT ONE END OF THE RUN OR INSIDE/OUTSIDE CORNER, ALIGN THE BOTTOM EDGE OF THE RAIL WITH THE PREVIOUSLY SNAPPED CHALK LINE AND PRESS FIRMLY AGAINST THE WALL. RUB EACH RAIL WITH A CLEAN SOFT CLOTH AND APPLY MEDIUM HAND PRESSURE TO ENSURE MAXIMUM ADHESION TO THE WALL SURFACE.

NOTE: WHEN INSTALLING FIELD MITERED SPLICES, IT IS RECOMMENDED THAT SPLICES BE GLUED AND BRAD NAILED TOGETHER.

NOTE: WHEN FIELD FORMING RADIUS FEATURE RAIL, BE SURE TO APPLY NEEDED PRESSURE ALONG WHOLE RAIL.

7. WHILE THE ADHESIVE IS DRYING, DISCRETELY APPLY SEVERAL BRAD NAILS THROUGH THE RAIL INTO THE WALL TO HOLD THE RAIL IN PLACE. IT IS RECOMMENDED TO APPLY THE BRAD NAILS NO LESS THAN 24" [609.6mm] O.C. USE THE CS SUPPLIED COLOR MATCHED FIL-STIK TO HIDE THE BRAD NAILS.

NOTE: IF INSTALLED WITH SARATOGA WALL SYSTEM BE SURE THE BRAD NAIL IS NOT INSTALLED THROUGH THE ACROVYN SHEET.