

**P-RWS HANDRAIL**

PLEASE READ

PLEASE READ THESE INSTRUCTIONS THOROUGHLY PRIOR TO BEGINNING THE P-RWS HANDRAIL INSTALLATION!

THIS INSTRUCTION SHEET IS INTENDED TO PROVIDE A SPECIFIC GUIDE TO FOLLOW FOR THE INSTALLATION OF THIS P-RWS HANDRAIL. CONTAINED WITHIN IS THE TECHNICAL INFORMATION AND INSTALLATION TECHNIQUES REQUIRED TO COMPLETE AN EFFICIENT, NEAT AND LONG-LASTING INSTALLATION.

INSPECT ALL MATERIALS FOR DAMAGE OR MISSING PARTS. IF YOU DISCOVER DAMAGED OR MISSING MATERIALS, IN THE USA PLEASE NOTIFY THE FACTORY AT (800) 233-8493, AND IN CANADA (888) 895-8955 FOR CUSTOMER SERVICE.

P-RWS HANDRAIL MUST BE INSTALLED IN ACCORDANCE WITH THESE INSTRUCTIONS! FAILURE TO FOLLOW THESE INSTRUCTIONS MAY VOID ANY PRODUCT WARRANTIES AND RESULT IN AN UNSUCCESSFUL INSTALLATION. FOR SPECIFIC QUESTIONS REGARDING THE INSTALLATION OF THIS P-RWS HANDRAIL PLEASE CALL THE FACTORY IN THE USA AT (800) 233-8493 OR EMAIL IWPTECHSUPPORT@C-SGROUP.COM. IN CANADA CALL (888) 895-8955.

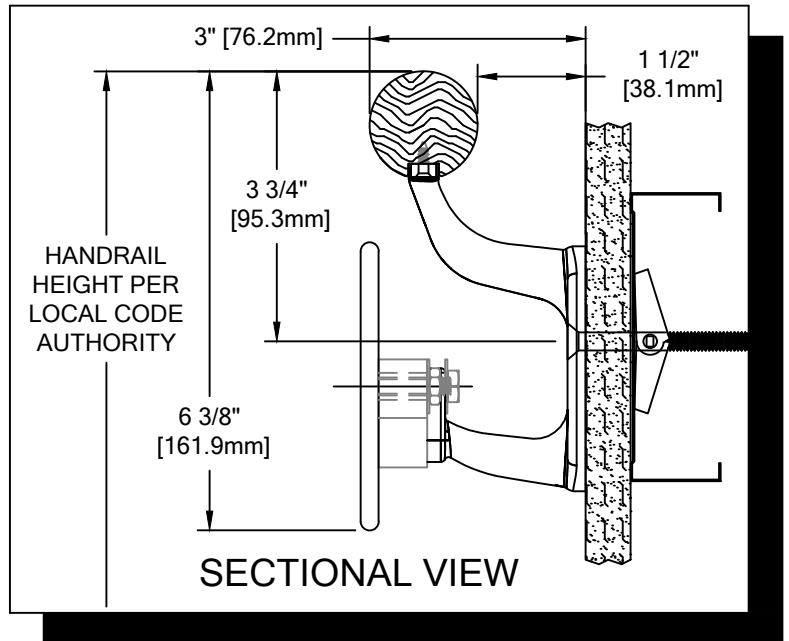

IMPORTANT NOTES

1. DUE TO WOOD BEING A NATURAL PRODUCT, COMPONENTS MAY GROW AND SHRINK AT DIFFERENT RATES. BECAUSE OF THIS, CS HAS DESIGNED THIS HANDRAIL TO UTILIZE A BEVEL AS SHOWN IN THESE INSTRUCTIONS (SEE FIGURE 1). THIS BEVEL MUST BE APPLIED AT ALL WOOD JOINTS AND MUST MATCH FACTORY BEVEL ON END CAPS.
2. THIS HANDRAIL HAS BEEN MANUFACTURED TO CUSTOMER SPECIFIED DIMENSIONS AND CAN NOT BE CUT OR MODIFIED ON SITE. TO DO SO COULD VOID THE WARRANTY.
3. ALL DIMENSIONS ARE TYPICAL.
4. FOR DRYWALL/PLASTER WALL CONSTRUCTION, IT IS RECOMMENDED FOR FASTENERS TO BE ENGAGED INTO METAL/WOOD STUDS TO MAINTAIN MAXIMUM PULLOUT STRENGTH. IF DURING INSTALLATION YOU ENCOUNTER SPECIAL WALL CONDITIONS THAT DO NOT ALLOW FOR DIRECT ATTACHMENT TO THE STUDS PLEASE CONSULT YOUR LOCAL AUTHORITY HAVING JURISDICTION.
5. INSTALL OUTSIDE CORNERS FIRST.
6. INSTALL LONGEST RUN OF HANDRAIL FIRST.
7. WOOD HANDRAIL SPLICE SHOULD NOT EXCEED 3" [76.2mm] DISTANCE FROM A BRACKET.
8. MATERIAL MUST REACH 65°F MIN. TO 75°F MAX. 24 HOURS PRIOR TO INSTALLATION. THIS IS ESSENTIAL TO MINIMIZE EXPANSION AND CONTRACTION OF MATERIAL.
9. MAY REQUIRE USE OF FIRE PUTTY WHEN INSTALLED ON FIRE WALL WITH TOGGLE BOLTS. REFERENCE INSTRUCTIONS 24FIREPUTTY FOR FIRE PUTTY INSTALLATION.
10. THIS HANDRAIL REQUIRES A MINIMUM OF 2 MOUNTING BRACKETS PER UNIT. THE MINIMUM END CAP-TO-END CAP HANDRAIL LENGTH IS 16" [406.4mm].
11. FOR MORE INFORMATION ON P-RWS HANDRAIL SEE OUR WEBSITE AT [www.c-sgroup.com](http://www.c-sgroup.com).

**P-RWS HANDRAIL**

COMPONENTS & WALL FASTENERS



WOOD HANDRAIL  
(24W236xxx)



WOOD HANDRAIL END CAP  
(24W238xxx, RH SHOWN)  
(24W237xxx, LH)  
(24W239xxx, OSC)

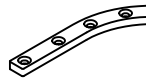

END CAP  
MOUNTING PLATE  
(90H142010)

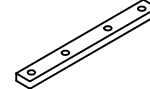

HANDRAIL SPLICE PLATE  
(90H150010)

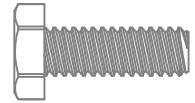

FASTENER #1  
1/4"-20 X 3/4" HEX  
HEAD MACHINE SCREW  
(90H008002)

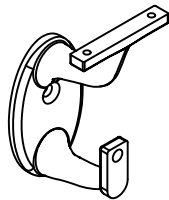

STAINLESS STEEL  
MOUNTING BRACKET  
(24S160000)

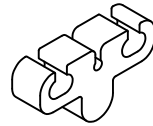

BRACKET ADAPTER  
PLATE  
(24F230003)



STAINLESS STEEL  
CRASH RAIL

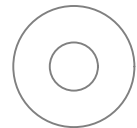

FASTENER #2  
1/4" FLAT WASHER  
(90H007003)



FASTENER #3  
1/4"-20 HEX NUT  
(90H010001)

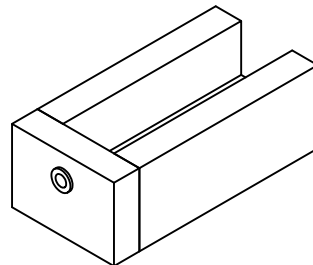

DRILL JIG  
(90H151010)

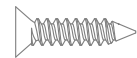

FASTENER #4  
#6 X 5/8" S/S PHILLIPS  
FLAT HEAD SMS  
(90H231004)

WALL CONDITION	SPECIFIED FASTENER	DRILL DIAMETERS		CS PART NUMBER
		WALL	RETAINER	
STEEL STUD/GYPSUM WALL	1/4-20 X 3" S/S FLAT HEAD BOLT WITH TOGGLE	3/4"	N/A	90H184002
CONCRETE/CONCRETE BLOCK	1/4" X 1 3/4" S/S FLAT HEAD MASONRY ANCHOR	3/16"	N/A	90H390000
WOOD STUD/GYPSUM WALL	#14 X 3" S/S PHILLIPS FLAT HEAD WOOD SCREW	7/32"	N/A	90H538004
20 GA. STEEL STUD/GYPSUM WALL (OSHPD)	1/4 - 20 X 3" S/S FLAT HEAD BOLT 1/4" TOGGLER WING 3M MOLDABLE FIRE PUTTY	1/2"	N/A	90H063002 90H062004 90M012000

P-RWS HANDRAIL

LAYOUT VIEW

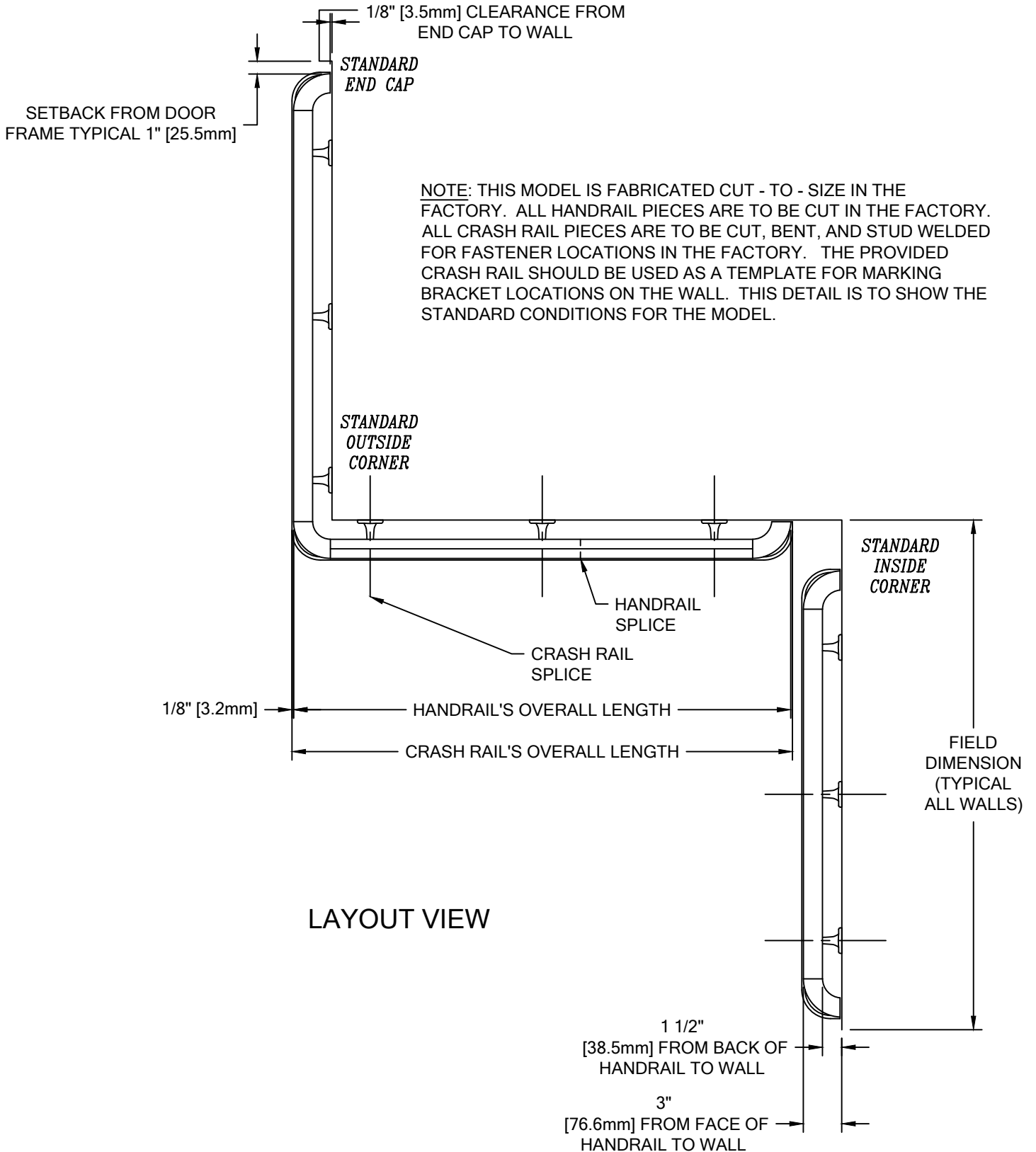

P-RWS HANDRAIL

TYPICAL ASSEMBLY

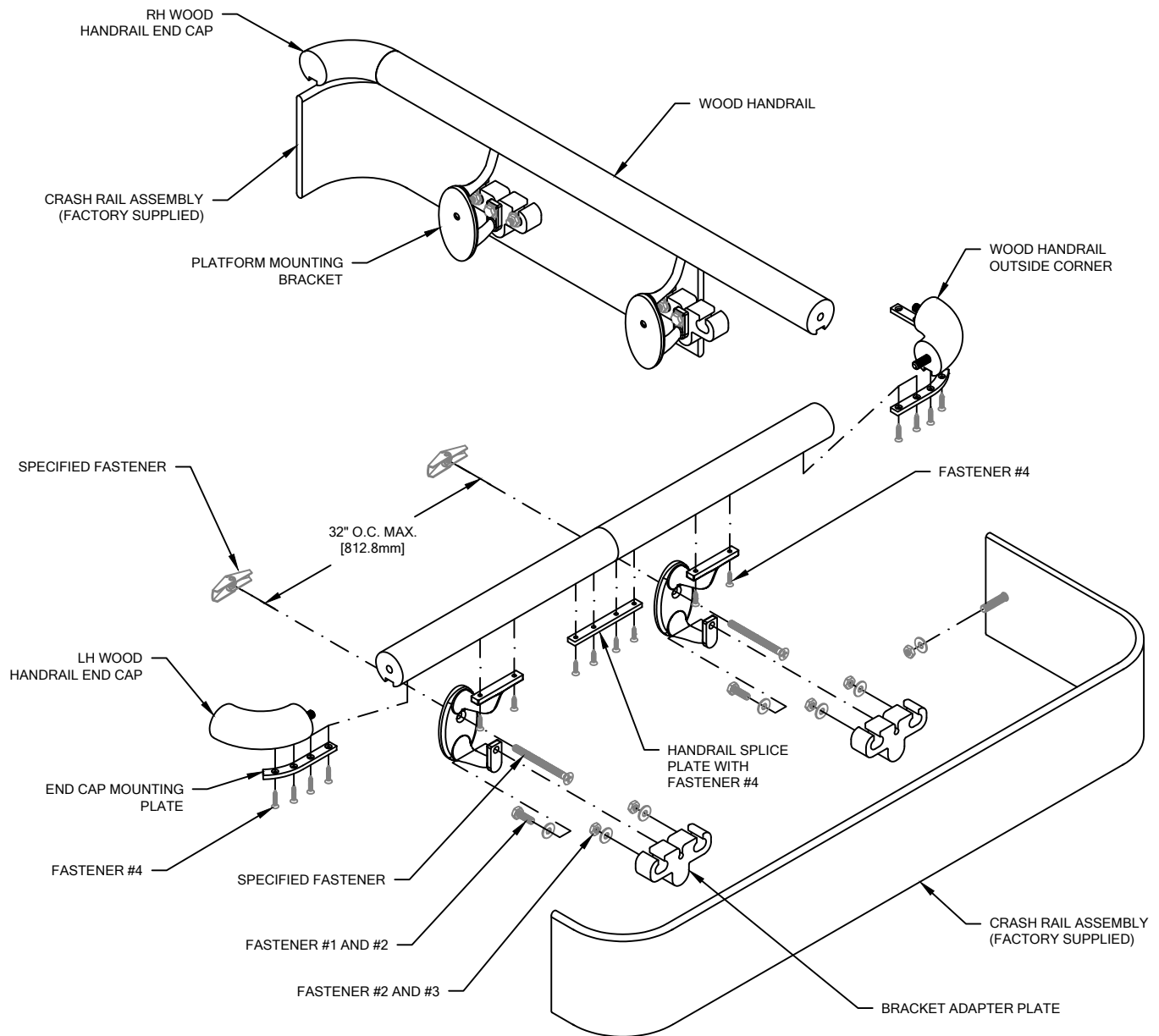

**P-RWS HANDRAIL**

TYPICAL HANDRAIL ASSEMBLY

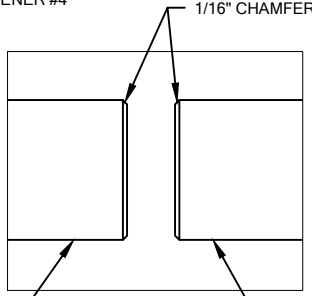
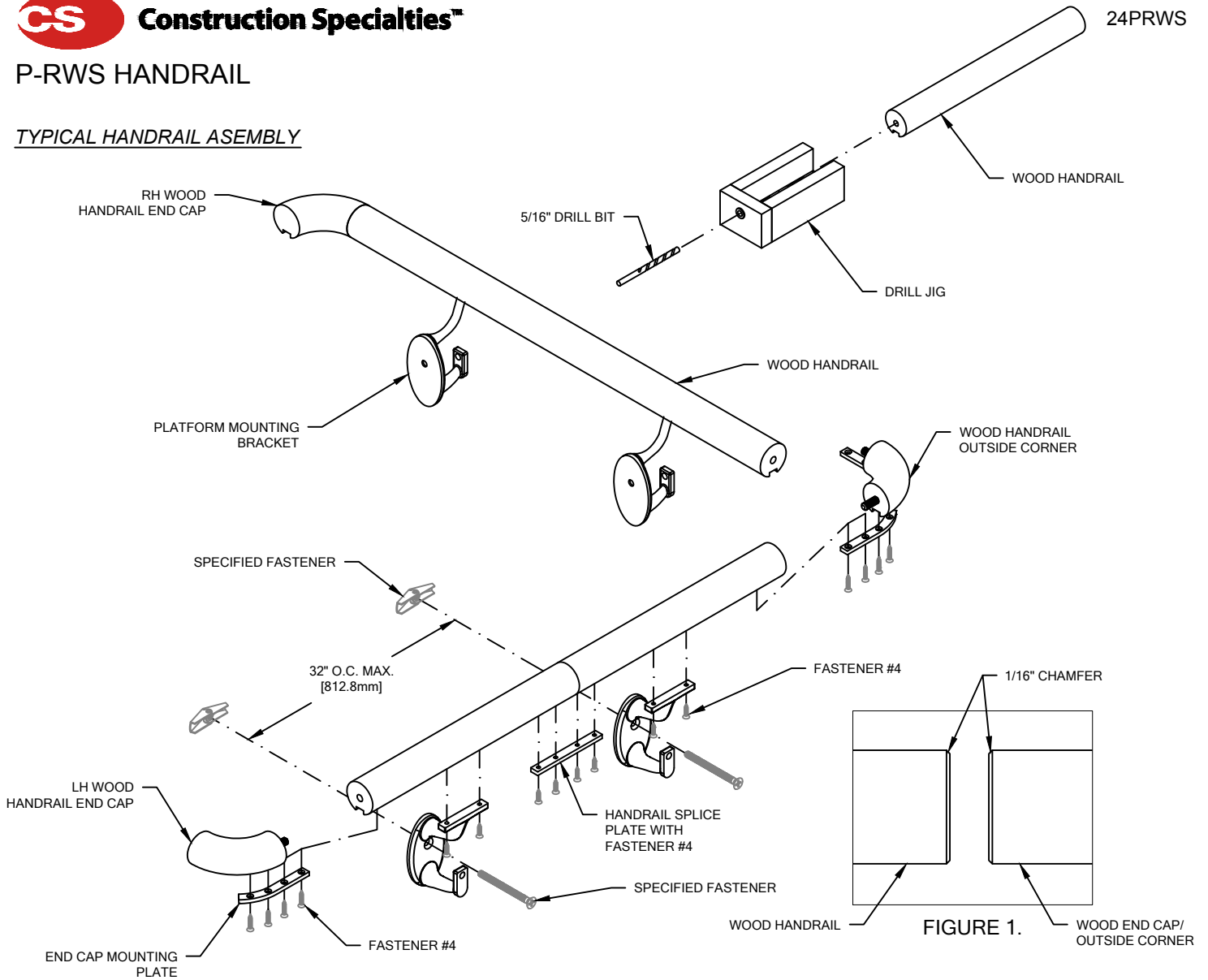

**FIGURE 1.**

**NOTE:** THIS MATERIAL HAS BEEN MANUFACTURED TO CUSTOMER SPECIFIED DIMENSIONS AND CAN NOT BE CUT OR MODIFIED ON SITE. TO DO SO COULD VOID WARRANTY.

1. USING "LOCAL CODE" REQUIREMENTS, ESTABLISH HANDRAIL HEIGHT ABOVE FINISH FLOOR. DEDUCT 3 3/4" [95.3mm] AND SNAP A CHALK LINE AT THAT HEIGHT. THIS MARKS THE LOCATION OF THE HOLE FOR THE MOUNTING BRACKET FASTENERS.
2. DRILL CLEARANCE HOLES IN WALL SURFACE FOR MOUNTING HARDWARE. REFERENCE CHART ON PAGE 2 FOR CORRECT DRILL DIAMETERS. USE CRASH RAIL WITH ATTACHED BRACKETS AS A TEMPLATE TO MARK BRACKET LOCATIONS ON THE WALL, REFERENCE STEP #9.
3. INSTALL MOUNTING BRACKETS USING APPROPRIATE FASTENERS. USE A LEVEL TO ENSURE THAT THE BRACKETS ARE LEVEL. WARNING: MOUNTING BRACKET LOCATIONS MUST BE IDENTICAL TO THE FACTORY INSTALLED STUDS ON THE BACKSIDE OF THE CRASH RAIL.
4. TO ENSURE PROPER ALIGNMENT OF HANDRAIL TO END CAP, USE THE END CAP DRILL JIG TO DRILL A HOLE FOR DOWEL PIN IN EACH END OF THE HANDRAIL. SEE ILLUSTRATION ABOVE.
  - LOCATE HANDRAIL TIGHT AGAINST DRILL JIG'S BOTTOM DRILL BUSHING.
  - DRILL 5/16" PILOT HOLE, 7/8" DEEP, IN EACH END OF THE HANDRAIL.
  - CONTINUALLY CLEAN OUT WOOD CHIPS AS THE PILOT HOLE IS BEING DRILLED.
5. ATTACH WOOD END CAPS TO WOOD HANDRAIL BY SLIDING THE END CAP DOWEL INTO THE ALIGNMENT HOLE IN THE HANDRAIL. BEFORE APPLYING WOOD GLUE, DRY FIT COMPONENTS TOGETHER TO DOUBLE CHECK FIT. APPLY WOOD GLUE INTO THE HOLE AND HANDRAIL SURFACE PRIOR TO END CAP INSERTION. TITEBOND WOOD GLUE IS RECOMMENDED FOR THIS APPLICATION. WIPE OFF ANY EXCESS GLUE.
6. ATTACH AN END CAP MOUNTING PLATE TO THE BOTTOM OF THE HANDRAIL AT THE END CAPS. USE THE MOUNTING PLATE AS A TEMPLATE TO DRILL 1/16" PILOT HOLES INTO THE WOOD. FASTEN THE MOUNTING PLATE TO THE HANDRAIL AND END CAP/OUTSIDE CORNER WITH FOUR #6 X 5/8" PHILLIPS FLAT HEAD SHEET METAL SCREWS.
7. DRILL 1/16" PILOT HOLES INTO THE WOOD HANDRAIL FOR MOUNTING BRACKET ATTACHMENT. MOUNTING BRACKETS ARE TO BE LOCATED 3" [76.2mm] FROM EACH END OF THE WOOD HANDRAIL AND 32" [812.6mm] ON CENTER ALONG LENGTH, AS REQUIRED.
8. FASTEN THE WOOD HANDRAIL TO THE WALL BRACKETS IN SUCCESSION BY INSERTING TWO #6 X 5/8" PHILLIPS FLAT HEAD SHEET METAL SCREWS THROUGH THE UNDERSIDE OF THE BRACKET INTO THE WOOD HANDRAIL. CAUTION: OVER-TORQUEING MAY CAUSE THE FASTENERS TO STRIP.

P-RWS HANDRAIL

TYPICAL CRASH RAIL ASSEMBLY

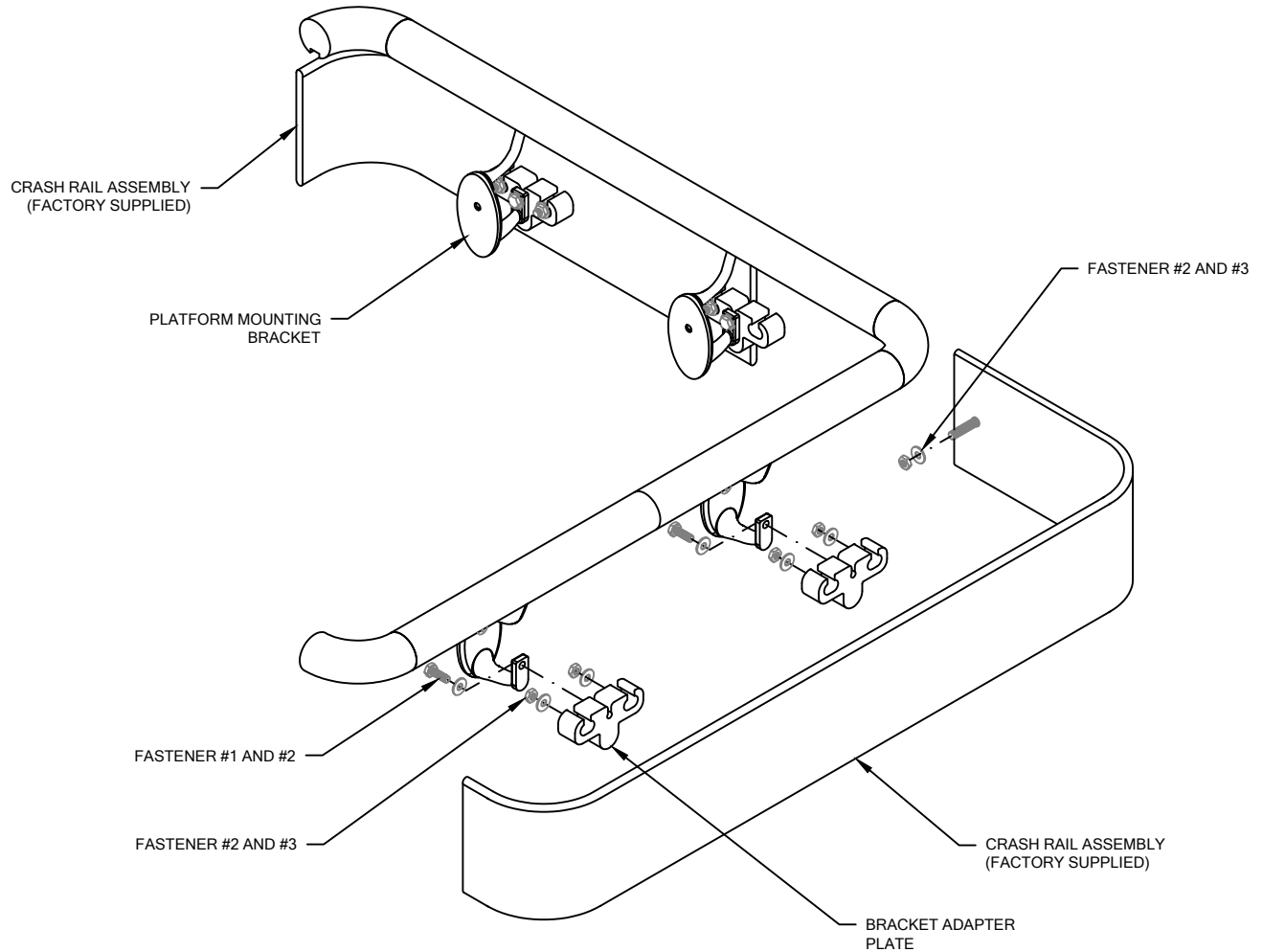

9. ATTACH CRASH RAIL TO THE WALL MOUNTING BRACKETS:
- DISTRIBUTE MATERIAL. MATCH THE NUMBER ON THE BACK OF THE RAIL TO THE MARK NUMBER ON THE DRAWING. SOME LARGE RUNS REQUIRE MORE THAN ONE PIECE OF CRASH RAIL. THESE ARE NOTED WITH A MARK NUMBER AND A LETTER, I.E., 2001A, 2001B.
  - LOCATE A BRACKET ADAPTER PLATE ON EACH SET OF THREADED STUDS ON THE BACKSIDE OF THE CRASH RAIL.
  - SECURE THE BRACKET ADAPTER PLATE BY INSTALLING A 1/4" WASHER AND 1/4-20 NUT ONTO EACH THREADED STUD.
  - ALIGN EACH MOUNTING BRACKET WITH THE BRACKET ADAPTER PLATE'S THREADED HOLE.
  - INSERT 1/4-20 HEX HEAD BOLT AND 1/4" WASHER THROUGH THE MOUNTING BRACKET AND INTO THE MOUNTING BRACKET'S THREADED HOLE. THE BRACKET ADAPTER PLATE IS SLOTTED TO ACCOMMODATE ANY SLIGHT MISALIGNMENT.
  - FASTENERS MUST BE TORQUED TO 150 IN/LBS.