

Wainscot Dimensional Moldings With Vertical Stiles

Please read these instructions thoroughly prior to beginning the wainscot Dimensional Moldings installation.

This instructions sheet is intended to provide a specific guide to follow for the installation of wainscot Dimensional Moldings. Contained within is the technical information and installation techniques required to complete an efficient, neat and long-lasting installation.

Wainscot Dimensional Moldings must be installed in accordance with these instructions! **Failure to follow these instructions may void any product warranties and result in an unsuccessful installation.** For specific questions regarding the installation of Wainscot Dimensional Moldings please call the factory in the USA at (800) 233-8493 or email iwptechsupport@c-sgroup.com. In Canada call (888) 895-8955.

IMPORTANT NOTES - DO NOT OVERLOOK

- The building environment where wainscot Dimensional Moldings are being installed must always be climate controlled.
- Ideal room temperature during installation is between 65° f - 75° f (18° c - 24° c).
- Room temperature after installation must always be maintained between 65° f - 75° f (18° c - 24° c).
- Allow materials to acclimate to facility room temperature (min. 24 Hours) before beginning the installation.
- If the quantity of sheets to be installed in a specific area is 25 or more, break the stack down to a maximum of 25 sheets.
- Shipment may contain more than one lot number, as noted on back side of sheets. Sort and install accordingly, failure to do so may result in shade variations.
- Do not expose wall covering to ultra-violet light sources, as this could cause fading and/or color variations.
- Radial material may be supplied factory formed or in straight lengths for field forming. Consult factory for options.

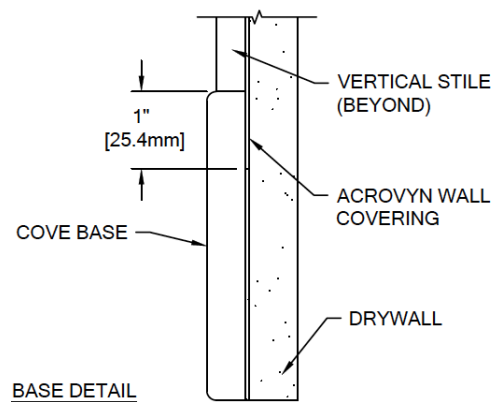
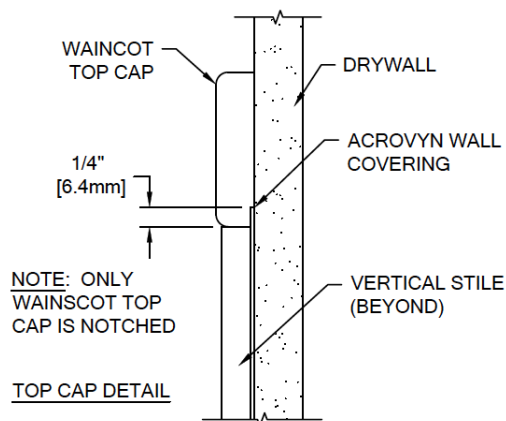

Wainscot Dimensional Moldings With Vertical Stiles

Do's & Don'ts

Do read all notes on the cover page about critical climate control recommendations before starting the installation.

Do read all instructions for wall primers & installation procedures prior to beginning the installation.

Do make sure the materials are kept flat and in a clean, dry area while in storage before acclimating them. Material should be well supported and the temperature should be a min. 50° f (10° c) and max. 100° f (38° c).

Do make certain porous substrates like drywall or concrete block are sealed with primer before adhesive application.

Do wipe the back of the wall covering with a clean damp cloth to remove any dust or dirt just before installing.

Do apply the adhesive to the wall surface only.

Do allow the mastic adhesive to cure properly. Under ideal conditions, curing time will be approximately 30 min. However, it will vary depending on temperature and relative humidity. The mastic adhesive cure time for applications over nonporous substrates is critical and will also vary.

Do allow the M-1 structural adhesive to cure properly. Under ideal conditions, curing time will be approximately 24 hours, however it will vary depending on temperature and relative humidity.

Do remove excess adhesive immediately. Dried adhesive is to be removed from tools using paint thinner or a similar solvent.

Do drill oversize holes when installing fixtures such as handrails, air ducts, etc. If another contractor is to install these items, be certain to notify them that oversized holes are necessary.

Do refer to the MSDS for disposal of extra adhesive and primer.

Don't stand sheet on end.

Don't install sheets exceeding 12'-0" [3.7m] long.

Don't use polyvinyl acetate (PVA) based primers or joint compounds in conjunction with Acrovyn interiors water based mastic.

Don't use any primers or adhesives other than those recommended for use with this product.

Don't use adhesive, primer or caulk that has frozen and thawed more than 3 times.

Don't dilute Acrovyn interiors water based mastic with water or solvent.

Don't begin the installation if the relative humidity is above 80%.

Don't butt wall covering tight against door jambs, ceilings or baseboards. Allow a 1/16" [1.6mm] gap for expansion.

Don't expose wall covering to elevated temperatures or direct sunlight after the installation. This causes the surface temperature to rise, which will cause bubbles and delamination.

Don't use Methyl Ethyl Ketone (MEK), cleaners containing MEK or similar solvents to clean Acrovyn wall covering.

Don't use scotch-brite pads, steel wool or similar cleaning pads on Acrovyn wall covering.

Don't install Acrovyn wall covering when the room temperature is below 65° f (18° c).

Don't rush the installation!

If there are any doubts or concerns about the installation, perform a trial installation before beginning the project. Should you have any questions regarding the installation, please call the factory in the USA at (800) 233-8493 or email iwptechsupport@c-sgroup.com. In Canada call (888) 895-8955.

Wainscot Dimensional Moldings With Vertical Stiles

Tools & Equipment

Supplied by Contractor

- Chalk Line
- 6'-0" Level (or Larger)
- Straight Edge
- Drop Cloth
- Masking Tape
- Utility Knife
- Water Bucket
- Mild Detergent
- Brad Nails (18 GA X 1-1/2" Length)
- Caulk Gun
- Electric Shears
- Spiral Saw
- Paint Tray & Roller (If Using Primer)

Supplied by Construction Specialties

- 1/8" V-Notch Trowel
- Acrovyn Interiors Heavy Duty Water Based Mastic Adhesive
- Primer (If Required) (Coverage: 350-400ft²/Gal.)
- M-1 Structural Adhesive
- Color Matched Fil-Stik

Optional Kit If Purchased Separately

- Crain #333 Extension Roller (95w010000)
- 1/8" V-Notch Trowel
- Color Matched Caulking
- Scissors
- Putty Knife
- Compass
- Utility Knife
- Sponge Pad
- Paint Tray & Roller

All Acrovyn sheet cuts can be performed by using electric shears, a spiral saw or a utility knife. Several cuts will be required to cut completely through if utilizing a utility knife.

Note: installation of lineal or radial Dimensional Molding trims should be done in accordance with the following instructions.

Wall Preparation - Examine all new or existing walls that are to receive Acrovyn wall covering. They must be clean, smooth, dry and free of any oils or loose paint prior to applying primer.

Specific Conditions:

New Drywall Or Plaster - New drywall should be taped and sanded smooth. When finished, all surfaces should be wiped clean to remove any dust. New plaster should be allowed to cure a minimum of 30 days.

Particle Board Or Plywood - New particle board or plywood should be smooth and all surfaces should be wiped clean to remove any dust to allow for best adhesion.

Painted Surfaces - Painted surfaces must be tested for adhesion. Apply a 12" x 12" (304.8mm x 304.8mm) piece of Acrovyn in an inconspicuous area. After allowing the sample to set for 24 hours, remove the test piece and examine the area. If the paint has softened where the adhesive was applied, the paint must be removed or sealed with primer. If the walls are drywall, test over a joint compound location if possible.

Existing Wall Coverings - When installing over existing materials like wallpaper or vinyl wall covering, the entire surface must be inspected for areas that are not securely bonded to the wall surface. Any loose areas must be removed and repaired as required. The existing wall covering should then be cleaned with a mild detergent and wiped dry. Be certain all cleaned areas are completely dry before proceeding.

Concrete / Concrete Masonry Units / Tile - This system is not recommended for use over concrete, cmu walls, or tile because of the unevenness of the walls and the need for brad nailing.

Wainscot Dimensional Moldings With Vertical Stiles

Step 1: Preventative Measures

Because Acrovyn has a grain direction, all material should be installed with the same top and bottom orientation. To prevent mistakes, mark the shipping cartons with top or bottom designation and install the material with this orientation throughout the project.

To ensure easy clean-up and/or prevent damage to adjacent finishes, provide a drop cloth at the base of the walls, mask door and window frame edges, and remove all cover plates like switches, outlets and thermostat covers.

Step 2: Wall Priming

Never use polyvinyl acetate primers! Allow at least 24 hours before installing wall covering over newly primed walls. The projected coverage is 350-400ft²/gal.

New Drywall or Plaster - Walls should be primed with primer.

Painted Drywall or Plaster - Painted walls must be checked for adhesion as described above under the wall preparation section. If the paint will not provide an acceptable base for adhesion, the most severe areas must be removed and primed with primer.

Wood Paneling, Plywood or Similar - These surfaces must be made smooth with a suitable filler and then primed with primer.

Flexible or Rigid Wall Covering Over Drywall or Plaster - Existing wall covering must be clean and its installation must be secure before installing Acrovyn wall covering. Priming is not necessary for these surfaces.

Wainscot Dimensional Moldings With Vertical Stiles

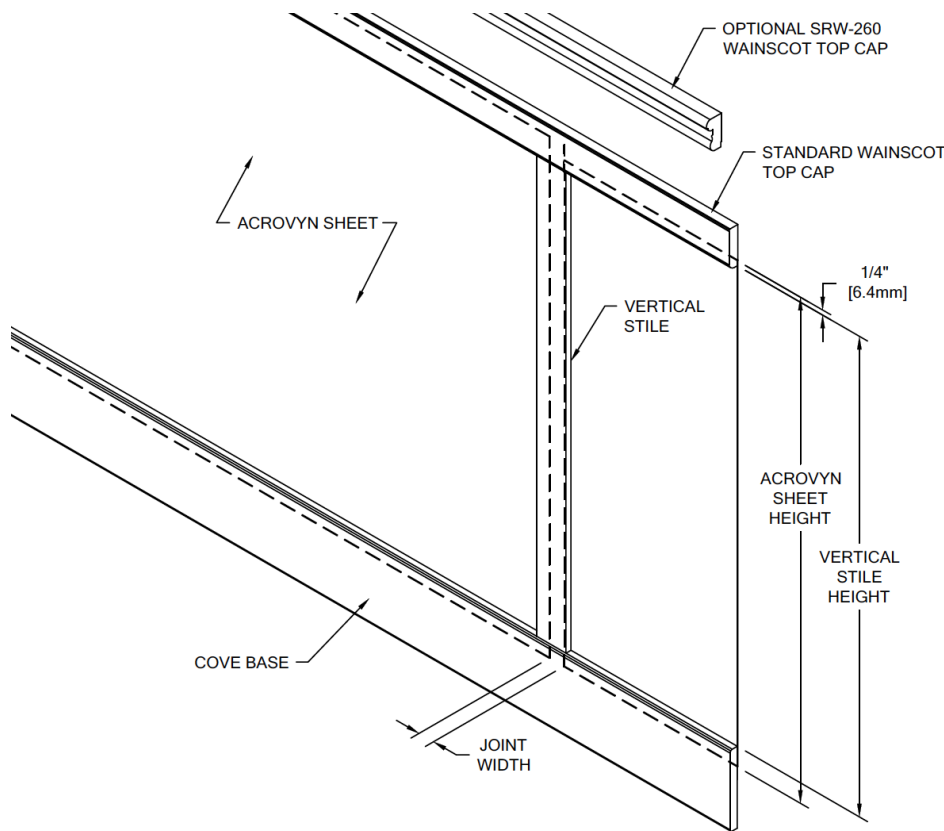

Step 3: Starting Procedures

Locate and install wainscot wall protection system in accordance with architectural drawings and specifications. When required, CS shop drawings should be used in conjunction with these documents.

Each wall must be treated individually to ensure all horizontal and vertical trims are aesthetically correct. Always refer to the base detail and top cap detail on page 1 which reflect the sheet location in conjunction with the base and the top cap. Also refer to the joint width chart on page 5 to determine the proper joint width required to match all trim widths being used on your job. (Example: 4" wide base trim requires a 3" joint width.) Proper joint widths are essential to ensure proper expansion and contraction of the sheet and to allow the trim to be directly glued to the wall.

Joint locations must be determined and then level lines should be established on the complete wall to indicate joint locations of all horizontal trims, vertical trims, starting location of the sheet off the finished floor, wainscot trim height and inside/outside corners. Once the joint locations for the complete wall are laid out, apply painters tape only in the joint areas to avoid adhesive being applied in these areas during the adhesive application process. Apply the adhesive to the joint only, and only apply brad nails through the trim and the substrate. The painters tape should be removed after the adhesive is applied to the wall.

Wainscot Dimensional Moldings With Vertical Stiles

JOINT WIDTHS				
MOLDING WIDTHS	2" [50.8mm]	4" [101.6mm]	6" [152.4mm]	8" [203.2mm]
BASE TRIM JOINT WIDTH	1" [25.4mm]	3" [76.2mm]	5" [127mm]	7" [177.8mm]
HORIZONTAL TRIM JOINT WIDTH	1" [25.4mm]	3" [76.2mm]	5" [127mm]	7" [177.8mm]
VERTICAL TRIM JOINT WIDTH	1" [25.4mm]	3" [76.2mm]	5" [127mm]	7" [177.8mm]

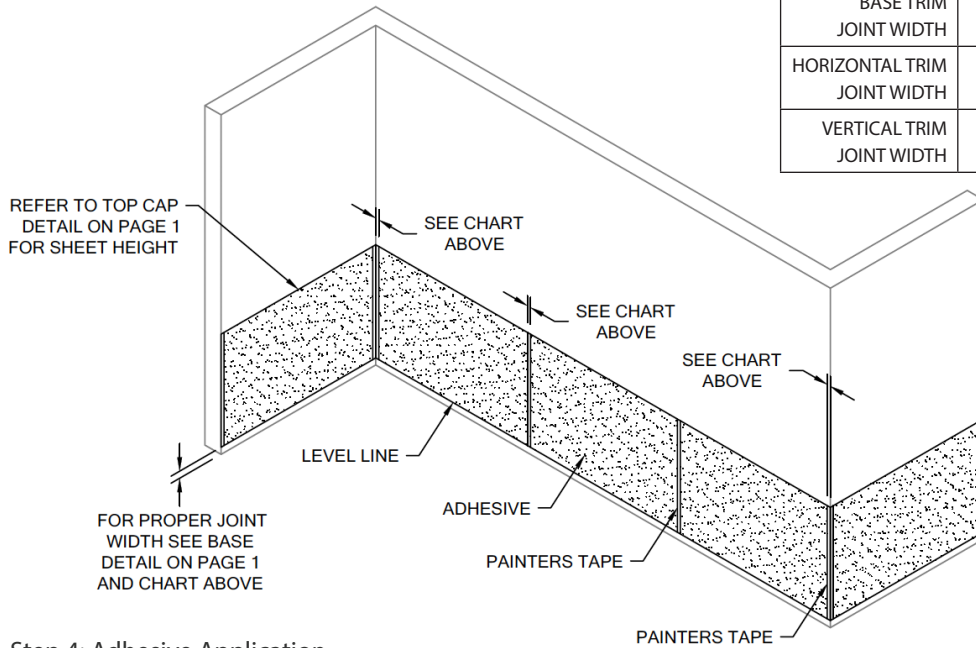

Step 4: Adhesive Application

Use the 1/8" [3.175 mm] v-notch trowel to apply Acrovyn interiors heavy duty water based mastic adhesive to an area of the wall surface that can be completed within the cure time of the adhesive. Make sure the entire area receives an even coat.

Do not allow the adhesive to over cure!

When applying the adhesive to the wall, the trowel must be held as close to perpendicular or 90 degrees to the wall as possible. Angles less than perpendicular reduce the amount of adhesive for proper installation and may result in delamination.

Be certain the trowel notches are cleaned regularly. Allowing the notches to fill with dried adhesive will reduce the application, which will cause failures because of inadequate adhesive. The projected coverage using the 1/8" [3.175 mm] v-notch trowel is 125 sq. ft. / gallon. Occasionally check the adhesive coverage to ensure the correct amount is being applied. Painters tape should be removed once the adhesive has been applied.

Under ideal conditions, the proper cure time of the adhesive should be approximately 30 min. But could be up to 2 hrs. However, this time will vary depending on temperature and relative humidity. The use of fans for air movement may help reduce the adhesive cure time. A dehumidifier may also be used in high humidity conditions to help reduce cure time. When applied, the adhesive is white and creamy. As it cures, the adhesive will become translucent and tacky. In a porous substrate application, it is best to install the wall covering when the adhesive has cured approximately 75% or when it becomes tacky and does not transfer onto your finger.

Nonporous surfaces like metal, high-pressure laminate or vinyl will not absorb moisture from the adhesive, thus retarding its cure time. It is important that the adhesive is firm, yet pliable, to the touch and that it does not transfer onto your finger. If the wall covering is installed before the adhesive has reached this stage, the moisture released by the curing adhesive will become trapped and at elevated temperatures the wall covering will bubble and/or delaminate. Once the adhesive has cured properly, the wall covering can be installed.

Wainscot Dimensional Moldings With Vertical Stiles

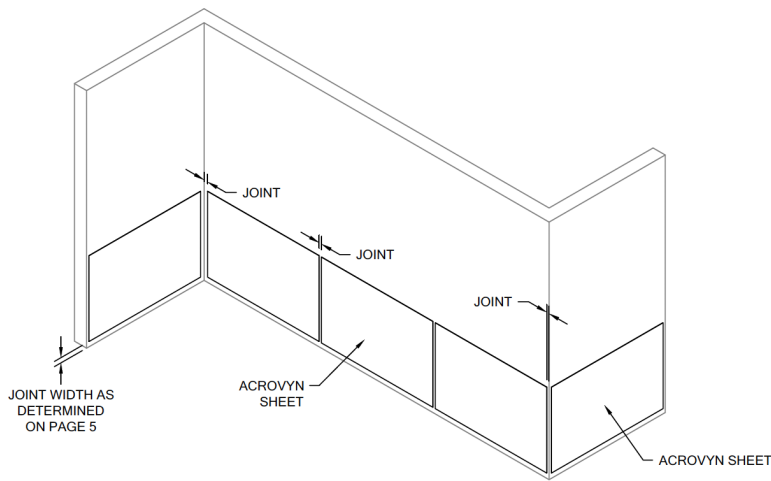

Step 5: Sheet Preparation and Cleaning

Prepare the first sheet by making any necessary cutouts. Remember to allow a 1/16" [1.6mm] gap around door and window frames, ceilings and baseboards. Use a straight edge to ensure neat cutouts. Place the sheet with the smooth side up and wipe the sheet with a clean damp cloth to remove any dust or dirt.

Step 6: Handling and Installation

Careless handling of Acrovyn wall covering could result in damage and unrepairable "kink" marks. Damage is less likely to occur when using two people to move and position the sheets.

Align the edge of the wall covering with the plumb or level lines established in step 3 and rub the wall covering along the edge no more than six inches from that edge. Continue this procedure over the full length of that edge of wall covering until it has been aligned. Lightly rub the remaining wall covering until all areas have made contact with the wall surface. Sheets can be repositioned as long as they are not pressed firmly into the mastic adhesive. Remember to maintain the appropriate joint width between the next sheets. **It is important to remove any excess adhesive with soap and water before it cures and becomes much more difficult to remove.**

Step 7: Smoothing Operation

Once the Acrovyn sheet has been aligned with the plumb line or adjacent sheet, use a roller to insure maximum contact with the Acrovyn interiors water based mastic adhesive. With the roller, start in the middle of the sheet and work toward the top, bottom and edges using full width strokes in an arching motion. By smoothing the sheet, you will also be able to remove any trapped air pockets. Once completed, run the palm of your hand over the entire surface feeling for bubbles or loose areas. Repeat the smoothing process as necessary until the entire sheet makes full contact with the adhesive.

Step 8: Clean Up

Upon completion of the installation, remove all protective materials (masking tape, etc.) Except for the drop cloths. Inspect all joints and cutouts to ensure that all excess adhesive has been removed. Use soap and water to clean any areas that may have adhesive residue. Once the inspection and clean-up have been completed, the drop cloths can be removed and the cover plates and other wall-mounted items can be installed.

Wainscot Dimensional Moldings With Vertical Stiles

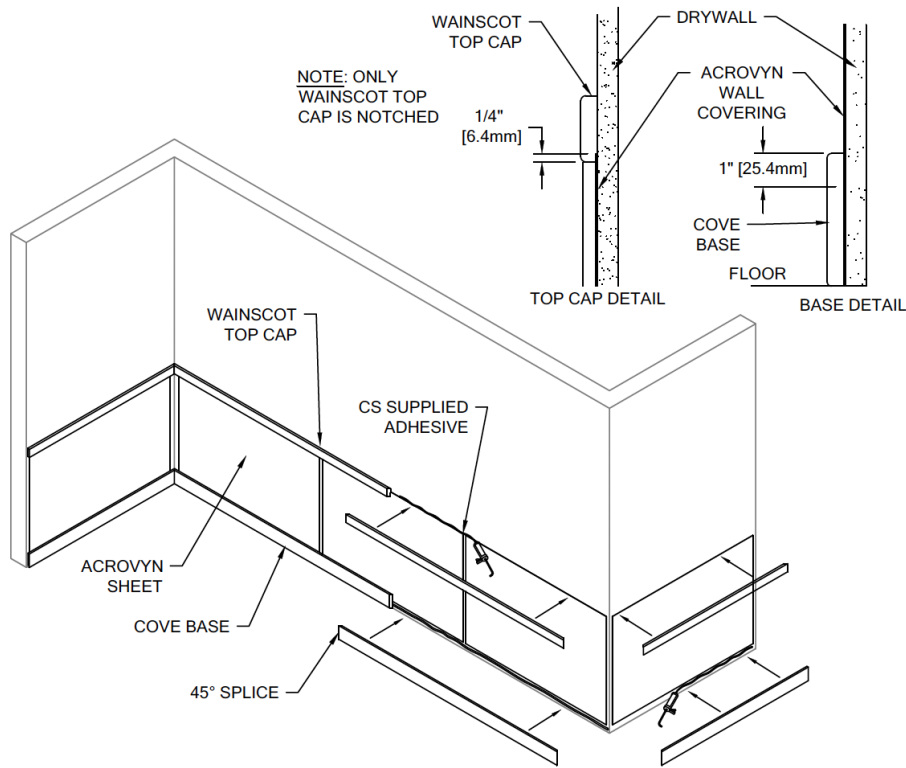

Step 9: Horizontal Trim Installation

Note: if installing optional plinth block outside corners see step 9a.

All wall surfaces must be clean, smooth, dry and free of any loose paint or any other irregularities which would prevent good adhesion.

Establish the horizontal trim height above the finish floor. Using a chalk line, make a level line to be used as a guide for aligning the top of the horizontal trim.

Cut horizontal trims to length. All inside/outside corners and splices are to be field mitered. At the end of a run, measure and cut final section to size. Note: it is recommended that horizontal trims be cut with an 80-100 tooth carbide tipped saw blade or equivalent.

When installing cove base, apply 1/4" [6.4mm] bead of CS supplied structural adhesive 1" [25.4mm] below the bottom edge of the previously installed sheet.

When installing wainscot top cap, apply 1/4" [6.4mm] bead of CS supplied structural adhesive 1/2" [12.7mm] above the top edge of the installed sheet.

Starting at one end of the run or inside/outside corners, begin installing the horizontal trim. Rub each trim with a clean soft cloth and apply medium hand pressure to ensure maximum adhesion to the wall surface. Note: when installing field mitered splices, it is recommended that splices be glued (titebond is recommended) and brad nailed together. When field forming radius horizontal trims, be sure to apply needed pressure across entire trim.

Wainscot Dimensional Moldings With Vertical Stiles

While the adhesive is drying, discretely apply several brad nails through the trim into the wall to hold the trim in place. It is Recommended to apply the brad nails no less than 24" [609.6mm] o.c. Be sure the brad nail is not installed through the Acrovyn sheet. Use the CS supplied color matched fil-stik to hide the brad nail.

Note: all horizontal trim inside/outside corners are to be field mitered. For inside corner conditions a file may be used on the Backside of the trim to accommodate any radius installed in the drywall.

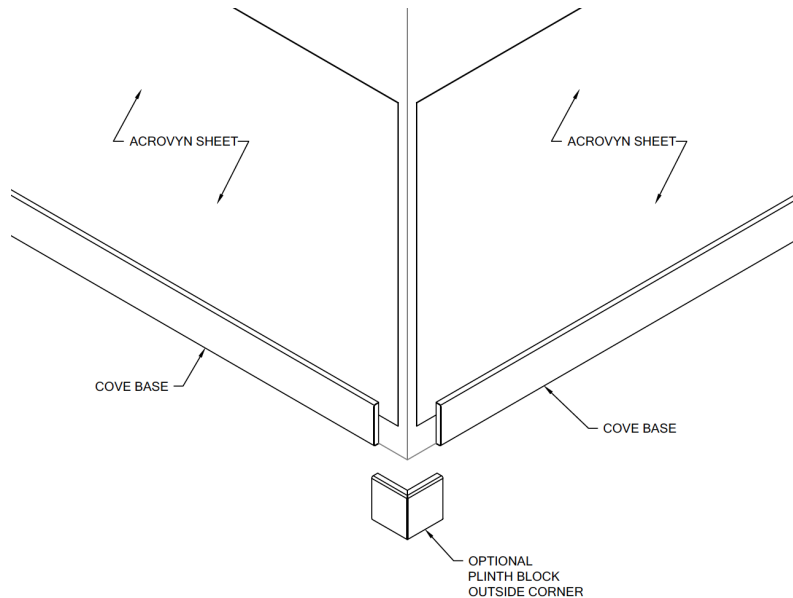

Step 9a: optional plinth block outside corner

All wall surfaces must be clean, smooth, dry and free of any loose paint or any other irregularities which would prevent good Adhesion.

Cut cove base to length as required. All inside corners and lap joints are to be field mitered. At the end of a run, measure and cut final section to size.

Note: it is recommended that Acrovyn cove base be cut with an 80-100 tooth carbide tipped saw blade or equivalent. Apply 1/4" [6.4mm] bead of CS supplied structural adhesive 1" [25.4mm] below the bottom edge of the previously installed sheet.

Starting at one end of the run or inside corners, begin installing the cove base. Rub each base with a clean soft cloth and apply Medium hand pressure to ensure maximum adhesion to the wall surface.

While the adhesive is drying, discretely apply several brad nails through the trim into the wall to hold the trim in place. It is Recommended to apply the brad nails no less than 24" [609.6mm] o.c. Be sure the brad nail is not installed through the Acrovyn sheet. Use the CS supplied color matched fil-stik to hide the brad nail.

Apply a 1/4" [6.4mm] vertical bead of CS supplied structural adhesive on each leg of the plinth block and install on outside corner. Apply medium hand pressure to ensure maximum adhesion to the wall surface. While the adhesive is drying, discretely apply several brad nails through the corner block into the wall to hold it in place. Be sure the brad nail is not installed through the Acrovyn sheet. Use the CS supplied color matched fil-stik to hide the brad nail.