

FLAT ROOF TO FLUSH WALL TRANSITION AT ROOF EDGE

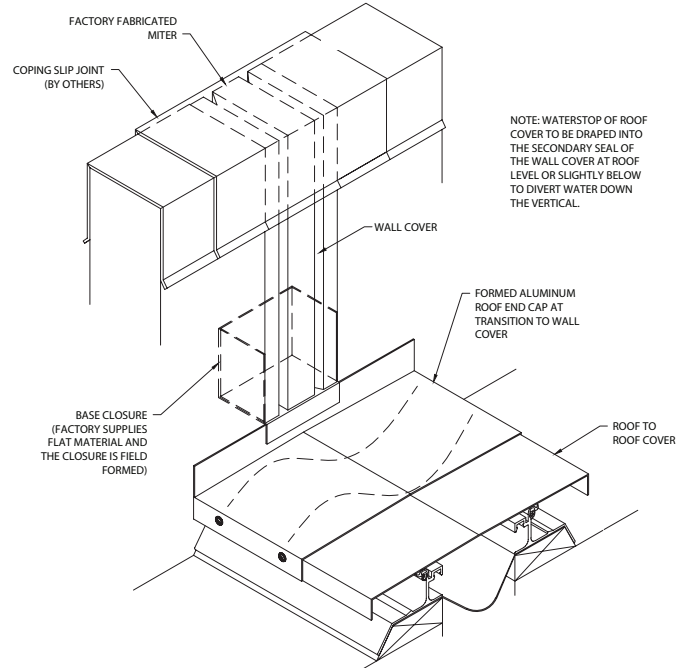

FLAT ROOF TO FLUSH WALL TRANSITION AT PARAPET

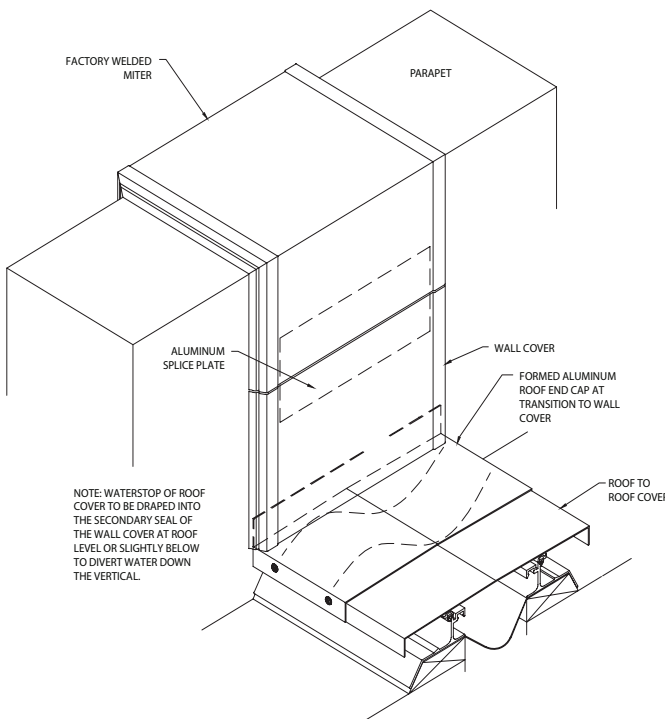

FLAT ROOF TO FLAT WALL TRANSITION AT PARAPET

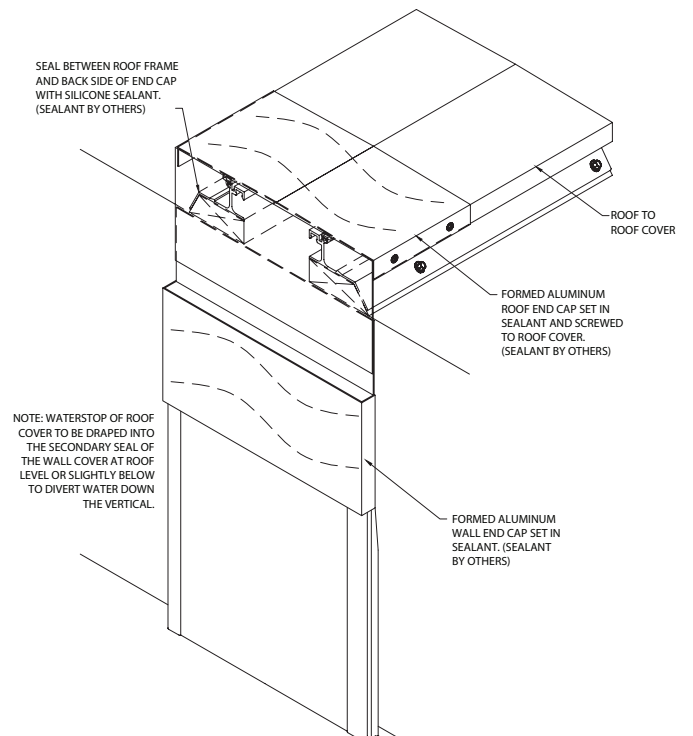

FLAT ROOF TO FLAT WALL TRANSITION AT ROOF EDGE

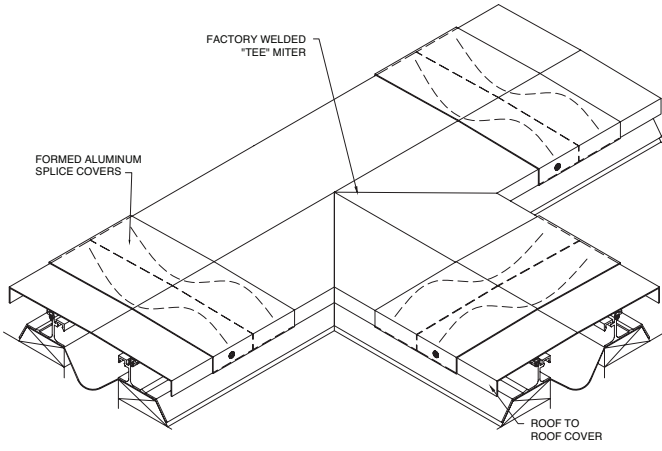

FLAT ROOF TEE MITER

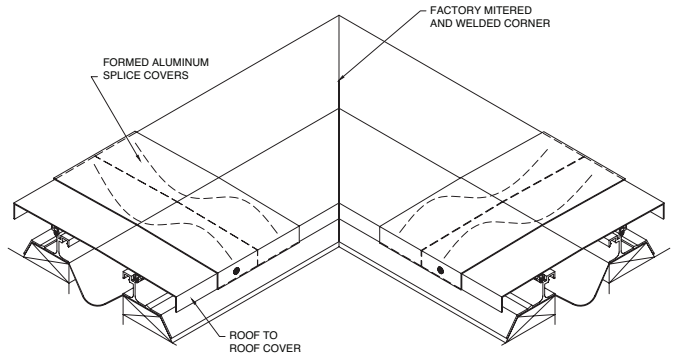

FLAT ROOF 90° MITER

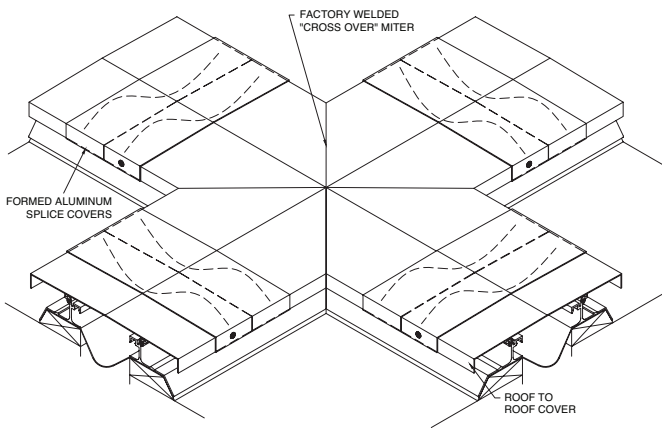

FLAT ROOF CROSS OVER MITER

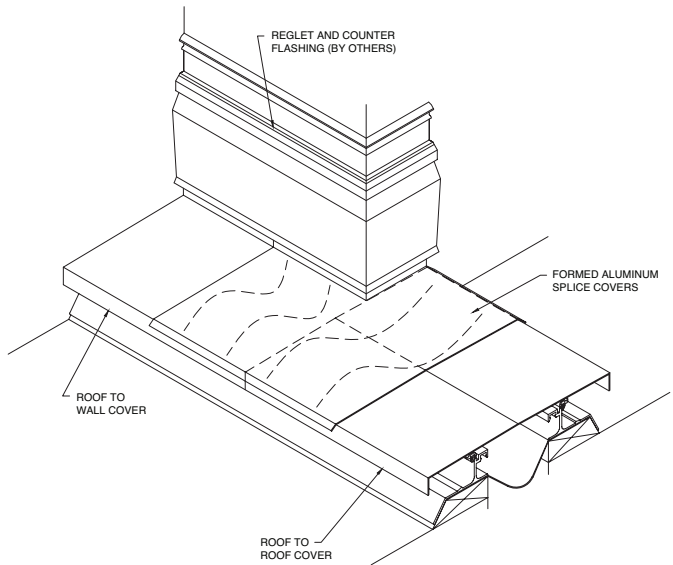

FLAT ROOF TO ROOF TO WALL TRANSITION

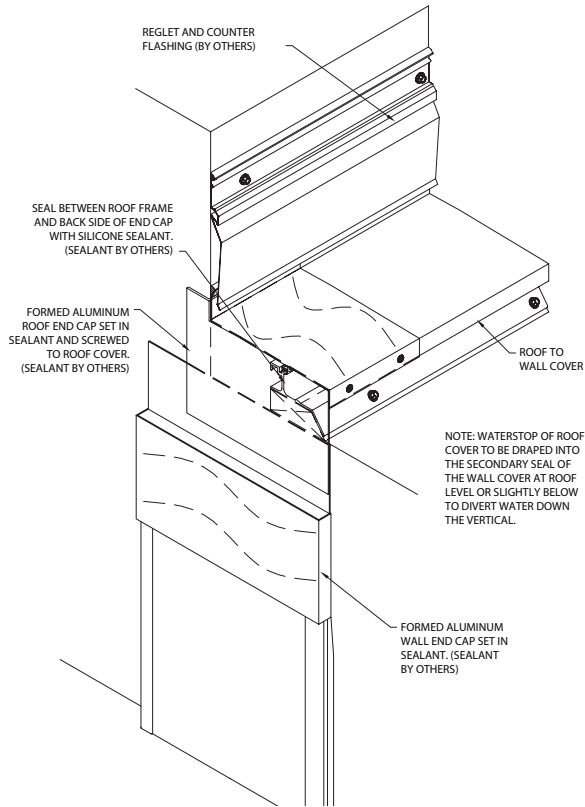

ROOF TO WALL TO FLAT WALL TRANSITION AT THE ROOF EDGE

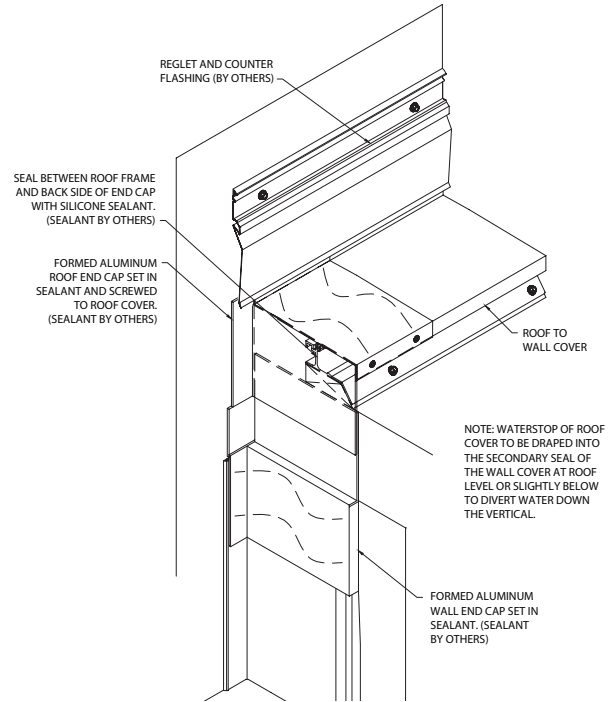

ROOF TO WALL TO CORNER WALL TRANSITION AT ROOF EDGE

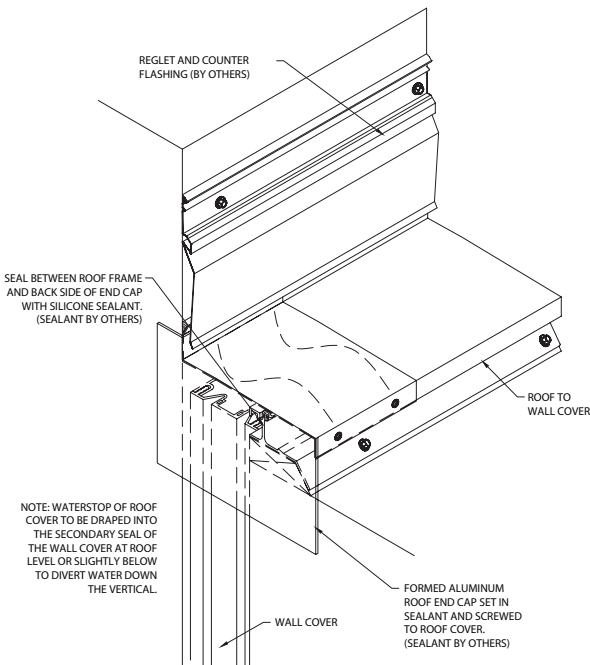

ROOF TO WALL TO FLUSH WALL TRANSITION AT ROOF EDGE

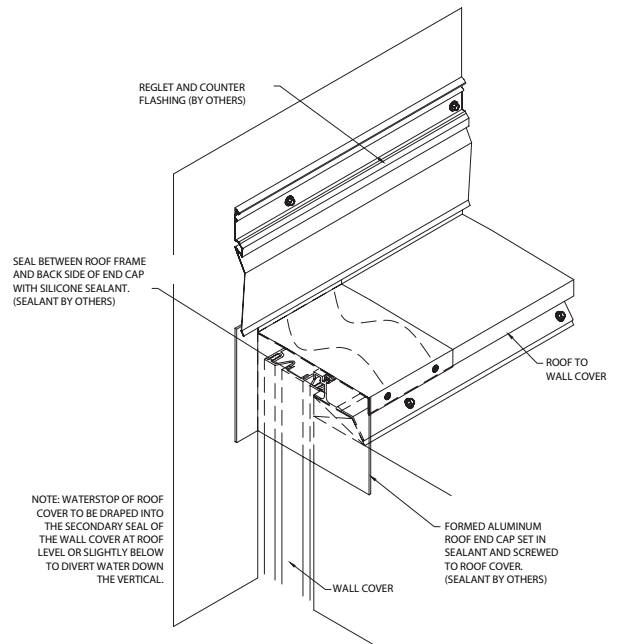

ROOF TO WALL TO FLUSH CORNER WALL TRANSITION AT THE ROOF EDGE

To download detail, specs & photos visit www.c-sgroup.com
 For technical and design assistance call 800-233-8493.

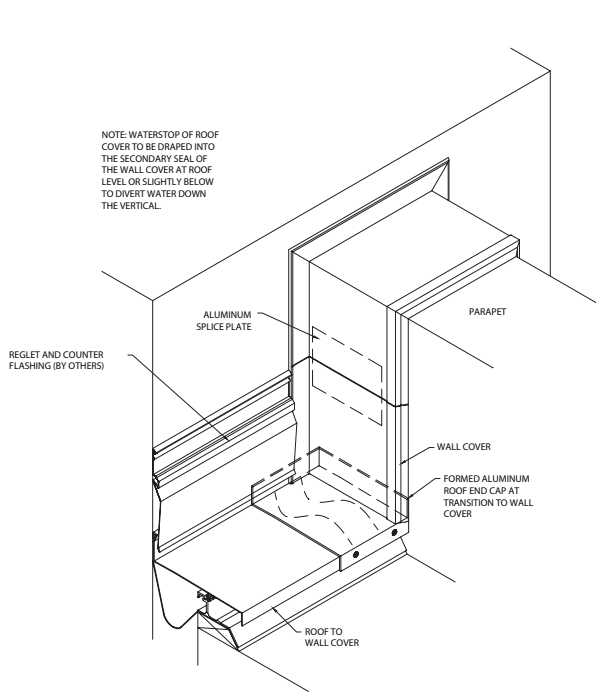

ROOF TO WALL TO CORNER WALL TRANSITION AT PARAPET

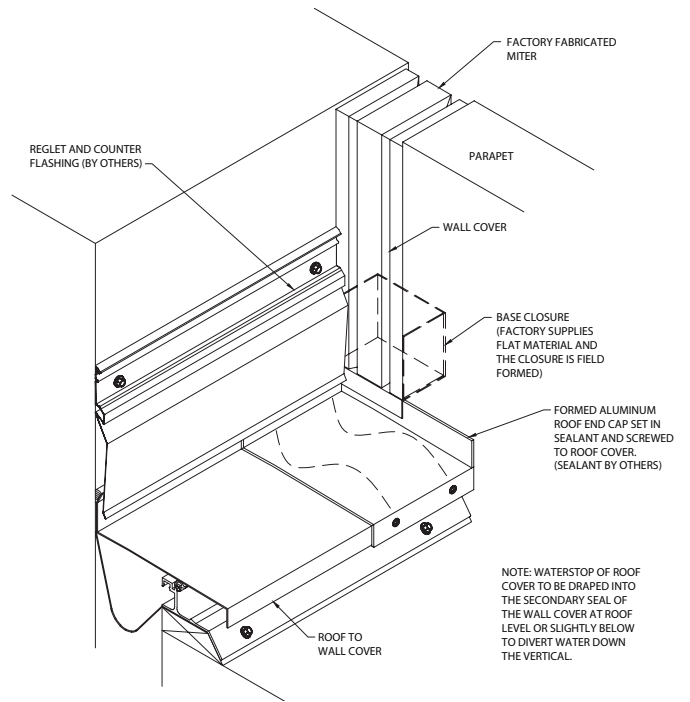

ROOF TO WALL TO FLUSH WALL TRANSITION AT PARAPET

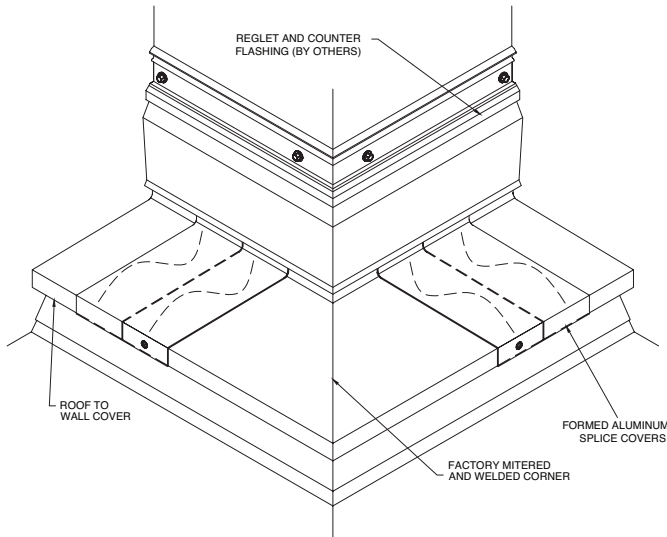

ROOF TO WALL 90° OUTSIDE CORNER MITER

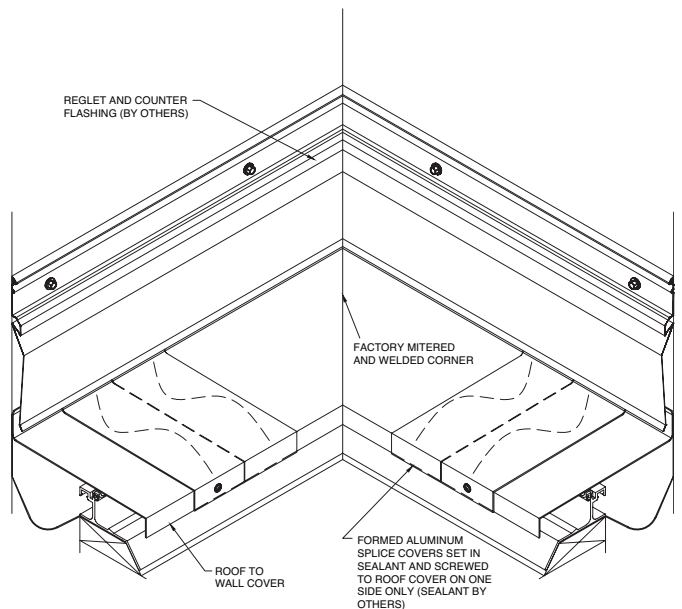

ROOF TO WALL 90° INSIDE CORNER MITER