

**COLOR:**  
**HANDRAIL WOOD SPECIES:** \_\_\_\_\_  
**HANDRAIL WOOD FINISH:** \_\_\_\_\_  
**\*MOUNTING BRACKET:** \_\_\_\_\_  
 COLOR TO BE SELECTED FROM ONE OF C/S STANDARD COLORS.

**\*MOUNTING BRACKET SUPPLIED IN STANDARD MILL FINISH. OPTIONAL CLEAR ANODIZED AND POWDER COAT FINISH AVAILABLE. PLEASE ADVISE POWDER COAT FINISH IF REQUIRED.**

TOTAL L/F REQ'D	LEFT END CAPS	RIGHT END CAPS

**NOTES:**

1. THIS MODEL IS FABRICATED CUT-TO-SIZE, THEREFORE FIELD VERIFIED DIMENSIONS ARE REQUIRED.

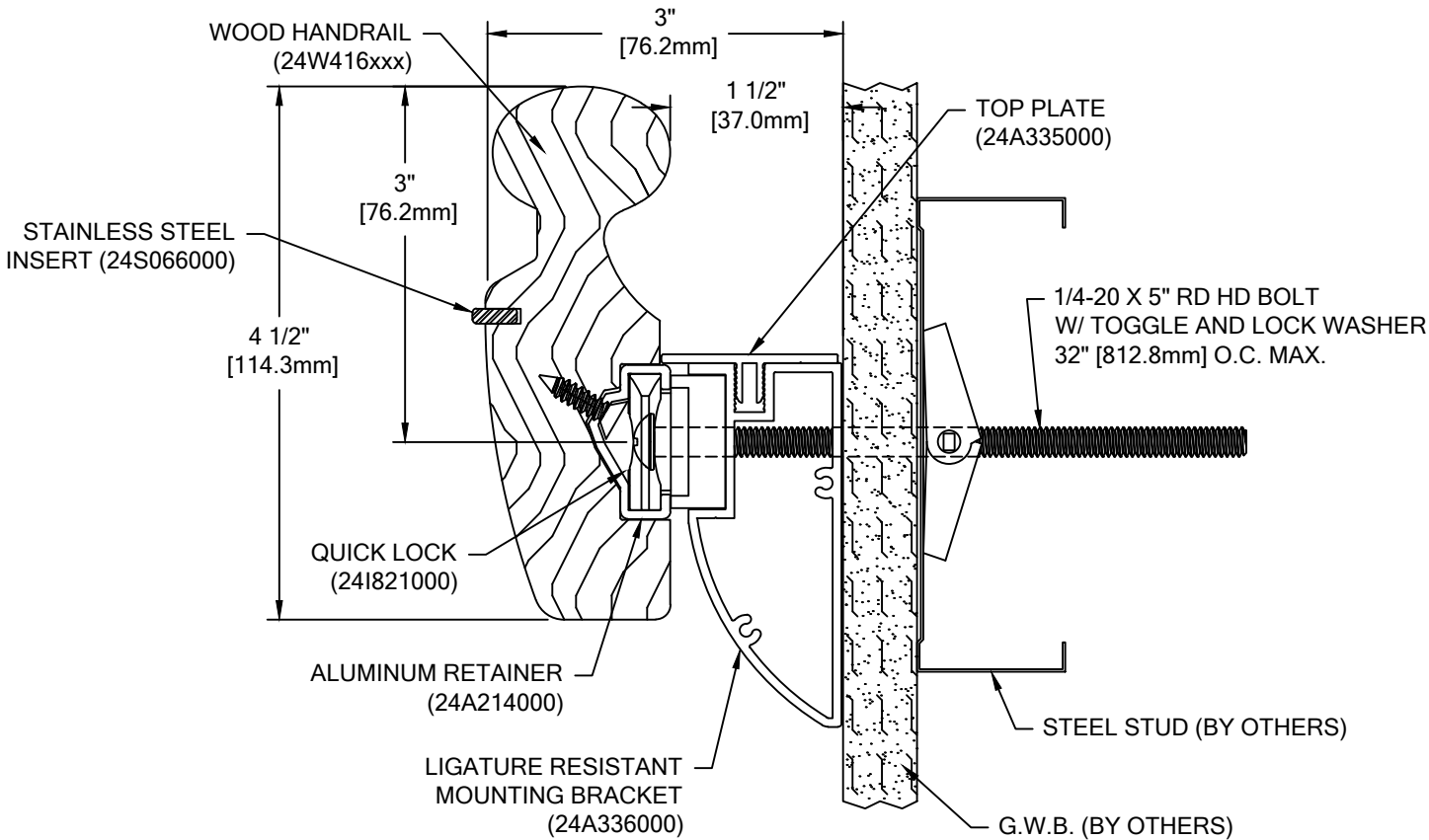

# HRW-20SCM

WALL CONDITION	SPECIFIED FASTENER	DRILL DIAMETERS		C/S PART NUMBER
		WALL	RETAINER	
STEEL STUD/GYPSUM WALL	1/4-20 X 5" ROUND HEAD BOLT WITH TOGGLE, AND LOCK WASHER	3/4"	9/32"	90H049002 90H006003
CONCRETE/CONCRETE BLOCK	#14 X 5" PHILLIPS RD HD ALL-PURPOSE SCREW	3/16"	9/32"	90H287002
WOOD STUD/GYPSUM WALL	#14 X 5" PHILLIPS RD HD ALL-PURPOSE SCREW	1/8"	9/32"	90H287002

 <p><b>Construction Specialties™</b>          6696 Route 405 Highway, Muncy PA 17756          (800) 233-8493 • Fax (570) 546-4692 • www.c-sgroup.com</p>	<b>PROJECT:</b>	<b>REVISION:</b>
	<b>JOB NO.:</b>	<b>F&amp;F:</b>
	<b>CUSTOMER:</b>	
	<b>REP:</b>	<b>DATE:</b>
	<b>DRAWN BY:</b>	<b>SHEET NO:</b>