

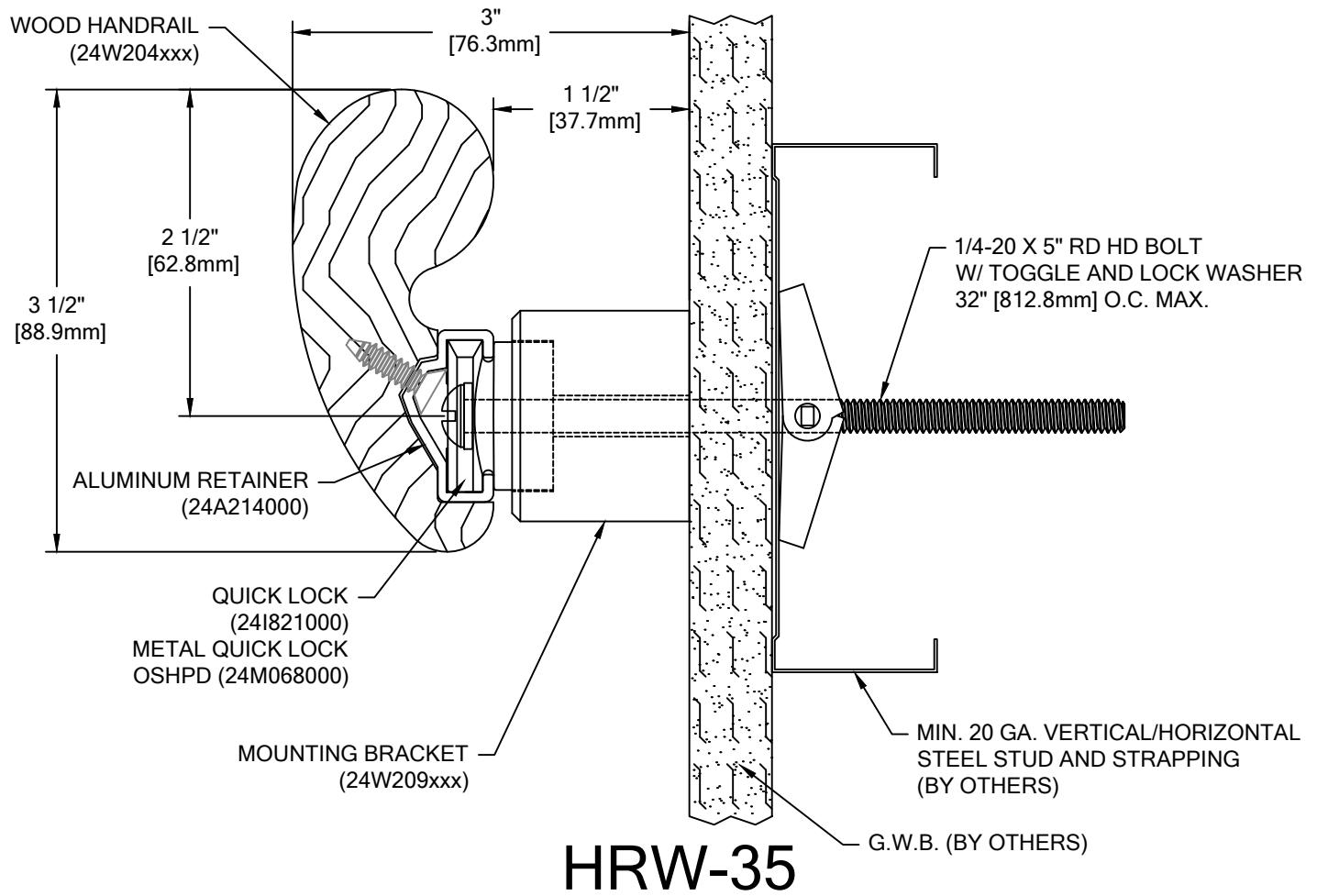

COLOR: _____
 HANDRAIL WOOD SPECIES: _____
 HANDRAIL WOOD FINISH: _____
 COLOR TO BE SELECTED FROM ONE OF C/S STANDARD COLORS.

| TOTAL L/F REQ'D | LEFT END CAPS | RIGHT END CAPS |
|-----------------|---------------|----------------|
| | | |
| | | |
| | | |



| WALL CONDITION | SPECIFIED FASTENER | DRILL DIAMETERS | | C/S PART NUMBER |
|---|--|-----------------|----------|--|
| | | WALL | RETAINER | |
| STEEL STUD/GYPSUM WALL | 1/4-20 X 5" ROUND HEAD BOLT WITH TOGGLE, AND LOCK WASHER | 3/4" | N/A | 90H049002 90H006003 |
| CONCRETE/CONCRETE BLOCK | #14 X 5" PHILLIPS RD HD ALL-PURPOSE SCREW | 3/16" | N/A | 90H287002 |
| WOOD STUD/GYPSUM WALL | #14 X 5" PHILLIPS RD HD ALL-PURPOSE SCREW | 1/8" | N/A | 90H287002 |
| 20 GA. STEEL STUD/GYPSUM WALL (OSHPD) | 1/4-20 X 5" RD. HD. BOLT WITH FLAT WASHER 1/4" TOGGLER WING 3M MOLDABLE FIRE PUTTY | 1/2" | N/A | 90H659002 90H007003 90H062004 90M012000 |
| 16 GA. MIN. STEEL STUD AND 16 GA. MIN. STEEL STRAPPING / GYPSUM WALL CONSTRUCTION REQUIRED (TEK SCREWS) | #14 X 5" PHILLIPS PAN HEAD #3 SELF DRILLING TEK SCREW ZINC PLATED | N/A | N/A | 90H286001 |

FABRICATION AND APPEARANCE OF THIS WOOD RAIL MATERIAL IS BASED ON FACTORY CUT AND ATTACHED END CAPS. IF STOCK SIZES ARE REQUIRED, END CAPS MUST BE CUT IN THE FIELD BY INSTALLER OR C/S WILL NOT GUARANTEE MATCH AND APPEARANCE OF CAPS TO RAIL.

| | | |
|--|------------------|------------------|
|  Hughesville, PA 800.233.8493 570.546.5941 Mississauga, ON 888.895.8955 905.274.3611 www.c-sgroup.com © Copyright 2018 Construction Specialties, Inc. | PROJECT: | REVISION: |
| | JOB NO.: | F&F: |
| | CUSTOMER: | |
| | REP: | DATE: |
| | DRAWN BY: | SHEET NO: |