

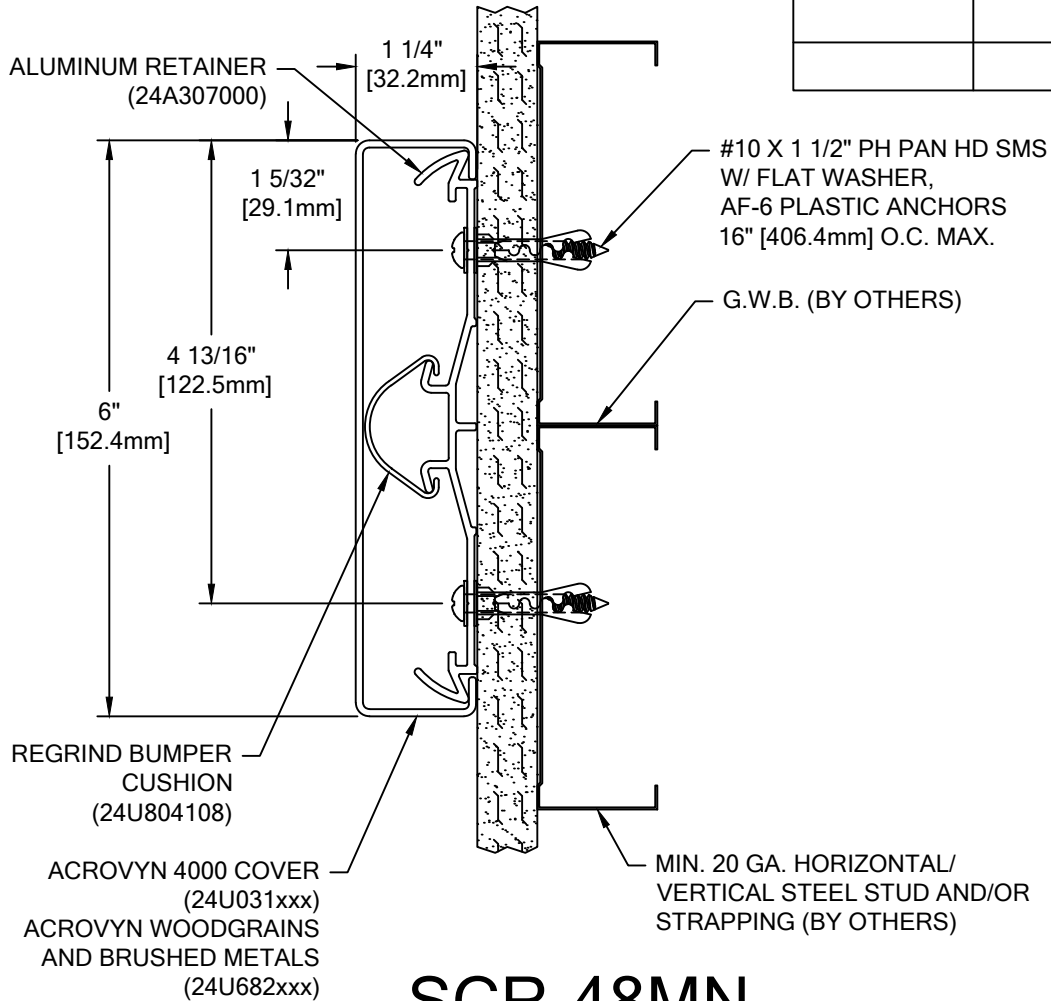

COLOR: \_\_\_\_\_  
 CRASH RAIL: \_\_\_\_\_  
 COLOR TO BE SELECTED FROM ONE OF C/S STANDARD COLORS.

TOTAL L/F REQ'D	END CAPS	O.S. REQ'D



## SCR-48MN ACROVYN 4000

WALL CONDITION	SPECIFIED FASTENER	DRILL DIAMETERS		C/S PART NUMBER
		WALL	RETAINER	
STEEL STUD/GYPUSM WALL	#10 X 1 1/2" PHILLIPS PAN HEAD SMS 1/4" FLAT WASHER SAE AF-6 PLASTIC ANCHOR	1/4"	9/32"	90H189002 90H007003 90H039004
CONCRETE/CONC. BLOCK	#10 X 1 1/2" PHILLIPS PAN HEAD SMS 1/4" FLAT WASHER SAE AF-6 PLASTIC ANCHOR	1/4"	9/32"	90H189002 90H007003 90H039004
WOOD STUD/GYPSUM WALL	#9 X 2 1/4" WAFER HD PH DRYWALL SCREW 1/4" FLAT WASHER SAE	N/A	N/A	90H421002 90H007003
20 GA. MIN. STEEL STUD AND 20 GA. MIN. STEEL STRAPPING / GYPSUM WALL (CONSTRUCTION REQUIRED) (TEK SCREWS)	#6 PHILLIPS BUGLE HEAD TEK SCREW	N/A	N/A	90H079002

 <p><b>Construction Specialties™</b>          6696 Route 405 Highway, Muncy PA 17756          (800) 233-8493 • Fax (570) 546-4692 • www.c-sgroup.com</p>	<b>PROJECT:</b>	<b>REVISION:</b>
	<b>JOB NO.:</b>	<b>F&amp;F:</b>
	<b>CUSTOMER:</b>	
	<b>REP:</b>	<b>DATE:</b>
	<b>DRAWN BY:</b>	<b>SHEET NO:</b>