

HRB-20CMN HANDRAIL

WITH INTERNATIONAL OFFSET

PLEASE READ

PLEASE READ THESE INSTRUCTIONS THOROUGHLY PRIOR TO BEGINNING THE HRB-20CMN HANDRAIL INSTALLATION!

THIS INSTRUCTION SHEET IS INTENDED TO PROVIDE A SPECIFIC GUIDE TO FOLLOW FOR THE INSTALLATION OF THIS HRB-20CMN HANDRAIL. CONTAINED WITHIN IS THE TECHNICAL INFORMATION AND INSTALLATION TECHNIQUES REQUIRED TO COMPLETE AN EFFICIENT, NEAT AND LONG-LASTING INSTALLATION.

INSPECT ALL MATERIALS FOR DAMAGE OR MISSING PARTS. IF YOU DISCOVER DAMAGED OR MISSING MATERIALS, IN THE USA PLEASE NOTIFY THE FACTORY AT (800) 233-8493, AND IN CANADA (888) 895-8955 FOR CUSTOMER SERVICE.

HRB-20CMN HANDRAIL MUST BE INSTALLED IN ACCORDANCE WITH THESE INSTRUCTIONS! FAILURE TO FOLLOW THESE INSTRUCTIONS MAY VOID ANY PRODUCT WARRANTIES AND RESULT IN AN UNSUCCESSFUL INSTALLATION. FOR SPECIFIC QUESTIONS REGARDING THE INSTALLATION OF THIS HRB-20CMN HANDRAIL PLEASE CALL THE FACTORY IN THE USA AT (800) 233-8493 OR EMAIL IWPTECHSUPPORT@C-SGROUP.COM. IN CANADA CALL (888) 895-8955.

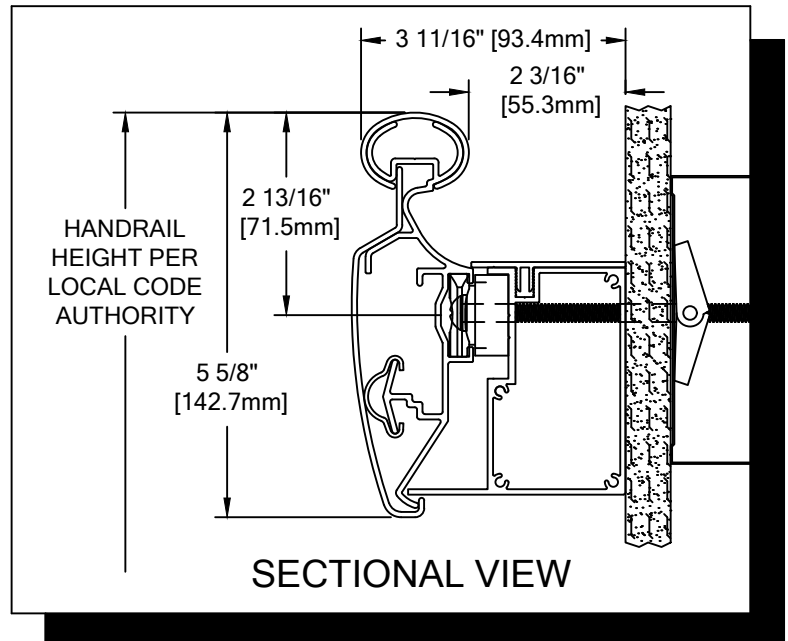

IMPORTANT NOTES

1. ALL LINEAL MATERIAL TO BE SUPPLIED IN STOCK LENGTHS. ALUMINUM AND ACROVYN IN LENGTHS UP TO 20'-0". THIS MATERIAL IS TO BE FIELD CUT USING QUALITY EQUIPMENT TO INSURE THAT ALL CUTS ARE SQUARE. WHEN CUTTING MATERIAL SECTIONS, CS RECOMMENDS USING AN 80-100 TOOTH CARBIDE TIPPED SAW BLADE OR EQUIVALENT, TO MINIMIZE CHIPPING AND MAINTAIN JOINT ALIGNMENT.
2. ALL DIMENSIONS ARE TYPICAL.
3. FOR DRYWALL/PLASTER WALL CONSTRUCTION, IT IS RECOMMENDED FOR FASTENERS TO BE ENGAGED INTO METAL/WOOD STUDS TO MAINTAIN MAXIMUM PULLOUT STRENGTH. IF DURING INSTALLATION YOU ENCOUNTER SPECIAL WALL CONDITIONS THAT DO NOT ALLOW FOR DIRECT ATTACHMENT TO THE STUDS, PLEASE CONSULT THE LOCAL AUTHORITY HAVING JURISDICTION.
4. INSTALL OUTSIDE CORNERS FIRST.
5. INSTALL LONGEST RUN OF HANDRAIL FIRST.
6. ALUMINUM RETAINER SPLICE SHOULD NOT EXCEED 4" [101.6mm] DISTANCE FROM A BRACKET.
7. THE DISTANCE BETWEEN AN ACROVYN SPLICE JOINT AND AN ALUMINUM RETAINER SPLICE JOINT SHOULD BE STAGGERED 4" [101.6mm].
8. MATERIAL MUST REACH 65°F MIN. TO 75°F MAX. 24 HOURS PRIOR TO INSTALLATION. THIS IS ESSENTIAL TO MINIMIZE EXPANSION AND CONTRACTION OF MATERIAL.
9. MAY REQUIRE USE OF FIRE PUTTY WHEN INSTALLED ON FIRE WALL WITH TOGGLE BOLTS. REFERENCE INSTRUCTIONS 24FIREPUTTY FOR FIRE PUTTY INSTALLATION
10. THIS HANDRAIL REQUIRES A MINIMUM OF 2 MOUNTING BRACKETS PER UNIT. THE MINIMUM END CAP-TO-END CAP HANDRAIL LENGTH IS 17" [431.8mm].
11. FOR MORE INFORMATION ON HRB-20CMN HANDRAIL SEE OUR WEBSITE AT www.c-sgroup.com.

HRB-20CMN HANDRAIL

COMPONENTS & WALL FASTENERS

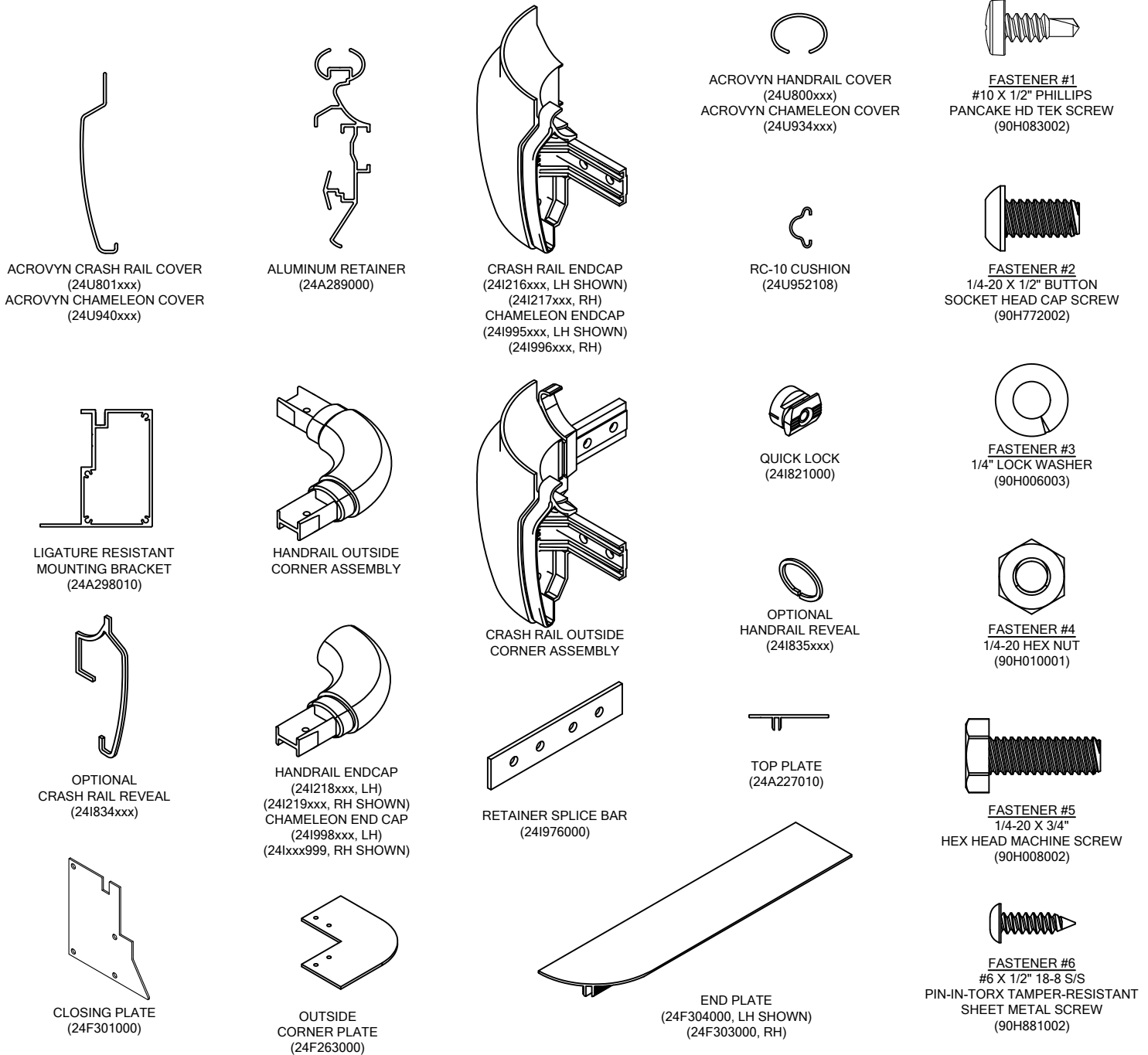

WALL CONDITION	SPECIFIED FASTENER	DRILL DIAMETERS		CS PART NUMBER
		WALL	RETAINER	
STEEL STUD/GYPSUM WALL	1/4-20 X 5" ROUND HEAD BOLT WITH TOGGLE, AND LOCK WASHER	3/4"	N/A	90H049002 90H006003
CONCRETE/CONCRETE BLOCK	#14 X 5" PHILLIPS RD HD ALL-PURPOSE SCREW	3/16"	N/A	90H287002
WOOD STUD/GYPSUM WALL	#14 X 5" PHILLIPS RD HD ALL-PURPOSE SCREW	1/8"	N/A	90H287002

HRB-20CMN HANDRAIL

LAYOUT VIEW

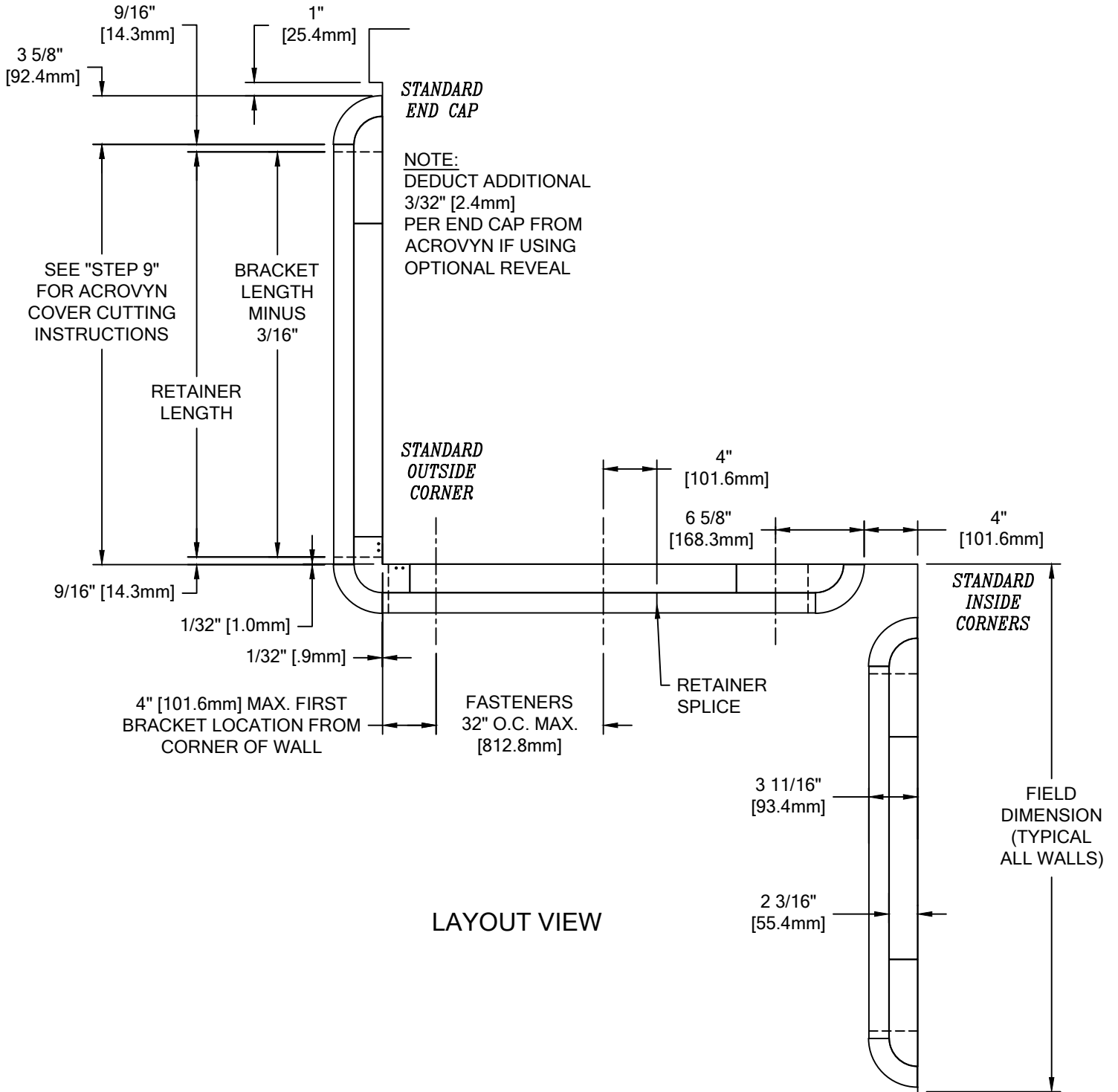

HRB-20CMN HANDRAIL

TYPICAL ASSEMBLY

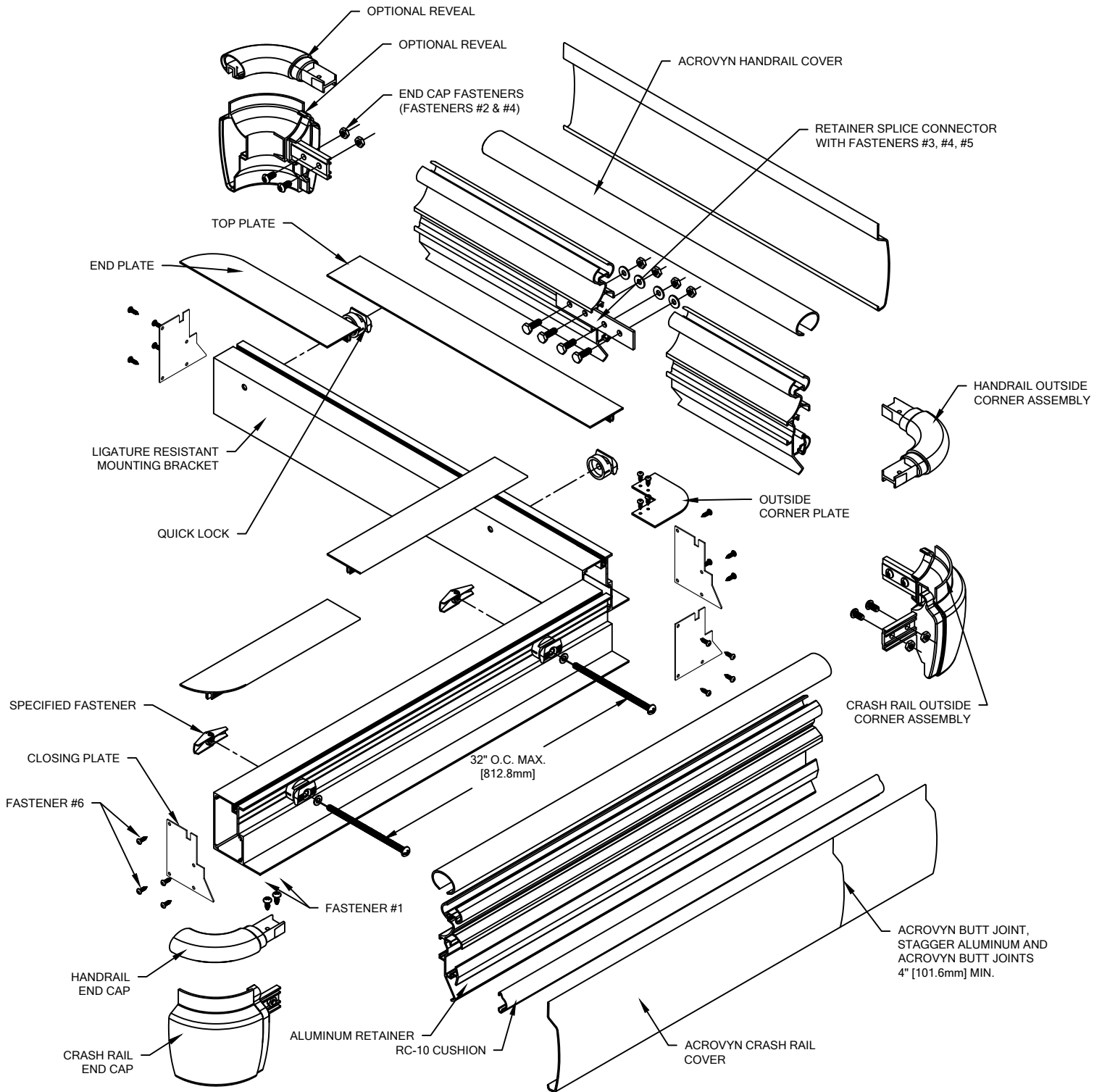

HRB-20CMN HANDRAIL

1. USING LOCAL CODE, ESTABLISH HANDRAIL HEIGHT ABOVE FINISH FLOOR. DEDUCT 2 13/16" [71.4mm] AND SNAP A CHALK LINE AT THAT HEIGHT. THIS MARKS THE LOCATION OF THE FASTENERS FOR THE HANDRAIL BRACKETS.
2. CUT THE LIGATURE RESISTANT MOUNTING BRACKET TO LENGTH USING THE REQUIRED DEDUCTIONS (SEE LAYOUT VIEW). PRE-DRILL CLEARANCE HOLES FOR THE SPECIFIED WALL FASTENERS IN THE LIGATURE RESISTANT MOUNTING BRACKET 4" [101.6mm] FROM EACH END. REFERENCE CHART ON PAGE 2 FOR CORRECT DRILL DIAMETERS. ALL OTHER BRACKET HOLES MUST NOT EXCEED 32" [812.8mm] ON CENTER. ATTACH ONE CLOSING PLATE WITH FOUR (4) #6 X 1/2" TAMPER-RESISTANT SHEET METAL SCREWS TO EACH END OF THE LIGATURE RESISTANT BRACKET BEFORE ATTACHING TO THE WALL.
3. PLACE A QUICK LOCK AT EACH CLEARANCE HOLE ON THE LIGATURE RESISTANT BRACKET. USING THE APPROPRIATE FASTENERS, ATTACH THE BRACKET ASSEMBLIES TO THE WALL AT THE PRE-DRILLED LOCATIONS. SEE ILLUSTRATION 1.
4. CUT THE CONTINUOUS ALUMINUM RETAINER TO LENGTH USING THE REQUIRED DEDUCTIONS AS NOTED (SEE LAYOUT VIEW).

NOTE: IT IS RECOMMENDED THAT THE ACROVYN COVERS AND ALUMINUM RETAINER BE CUT WITH AN 80-100 TOOTH CARBIDE TIPPED SAW BLADE OR EQUIVALENT.

5. CUT RC-10 CUSHION TO LENGTH NOTING REQUIRED DEDUCTIONS (SEE LAYOUT VIEW) AND INSTALL ONTO ALUMINUM RETAINER.

OPTIONAL: THE END CAPS AND COVERS MAY BE INSTALLED ONTO THE RETAINER FIRST, AND THE ASSEMBLY PLACED ONTO THE BRACKETS AS A COMPLETE UNIT AND THEN LOCKED INTO PLACE.

6. PLACE THE RETAINER ON THE WALL BRACKETS SO THAT THE HEAD OF EACH QUICK LOCK INSERTS INTO THE CHANNEL ON THE BACK OF THE RETAINER. USING THE WRENCH PROVIDED, TWIST EACH LOCK 90° TO SECURE THE BRACKET BASE INTO PLACE. SEE ILLUSTRATIONS 1 THROUGH 4. USE A LEVEL TO ENSURE RETAINER IS LEVEL.
7. ATTACH END CAPS/OR CORNER ASSEMBLIES BY LOOSELY THREADING TWO (2) 1/4-20 X 1/2" BUTTON SOCKET HEAD CAP SCREWS THROUGH THE BACKSIDE OF THE FLANGE OF EACH END CAP (FOUR (4) PER CORNER ASSEMBLY) INTO THEIR RESPECTIVE NUTS ON THE RETAINER SIDE OF THE FLANGE. SLIDE THE FLANGE INTO THE RECEIVER CHANNEL OF THE ALUMINUM RETAINER AND TIGHTEN THE BUTTON SOCKET HEAD CAP SCREWS FOR A SECURE FIT. SEE ILLUSTRATIONS 5 THROUGH 7.
8. ATTACH HANDRAIL END CAP TO RETAINER WITH TWO (2) #10 X 1/2" PHILLIPS PAN HEAD TEK SCREWS.
 - 8.1. INSERT END CAP INTO RETAINER.
 - 8.2. DRILL 1/8" DIAMETER PILOT HOLES THROUGH THE TOP OF THE RETAINER AND END CAP, 7/8" [22.2mm] AND 1 9/16" [39.7mm] FROM THE END OF THE RETAINER.
 - 8.3. REMOVE END CAP AND DRILL 11/64" CLEARANCE HOLES FOR THE #10 X 1/2" PHILLIPS PAN HEAD SCREW.
 - 8.4. ATTACH END CAP TO RETAINER WITH ABOVE MENTIONED SCREWS.

NOTE: TO AID IN LOCATING THE END CAPS CORRECTLY, CUT A 4" [101.6mm] SECTION OF COVER FROM SCRAP AND SNAP IT ON THE RETAINER. LOCATE THE CAP SO IT ALIGNS FLUSH WITH TOP AND BOTTOM OF THE COVER.

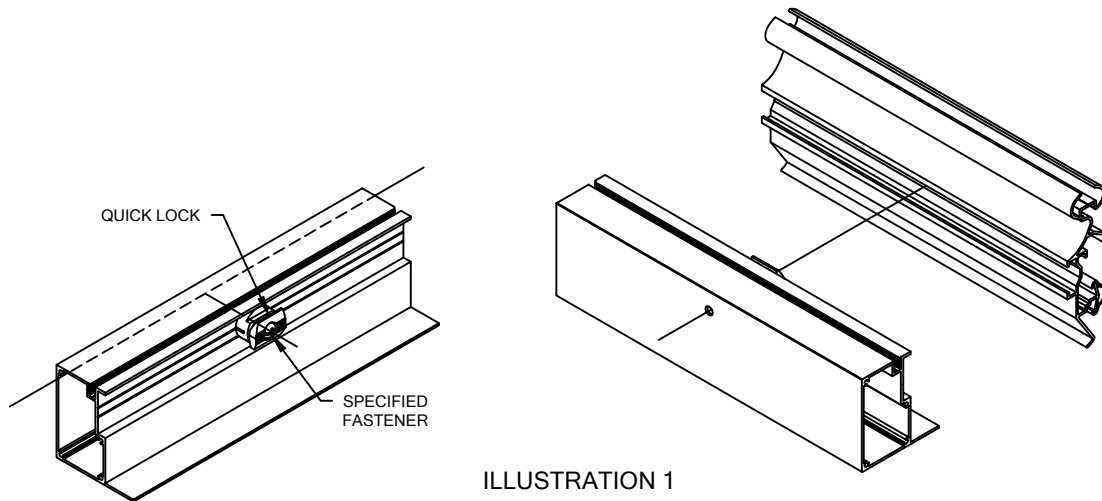

ILLUSTRATION 1

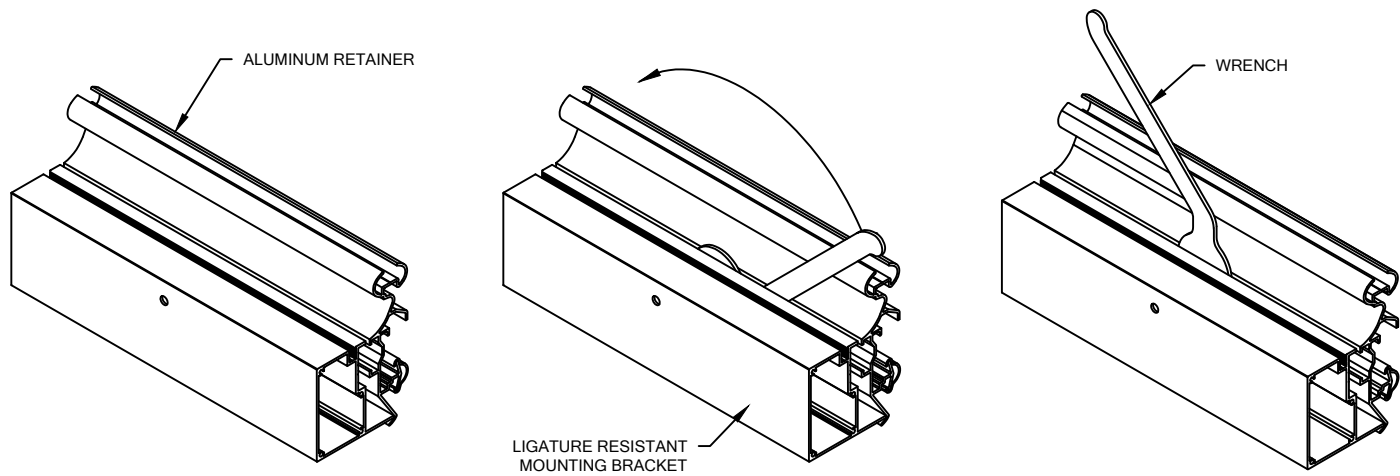

ILLUSTRATION 2

ILLUSTRATION 3

ILLUSTRATION 4

HRB-20CMN HANDRAIL

- CUT THE ACROVYN COVERS TO THE PROPER LENGTH. THE COVER LENGTH IS DETERMINED BY MEASURING THE DISTANCE BETWEEN THE INSTALLED END CAPS AND/OR OUTSIDE CORNER ASSEMBLIES.

NOTE: IT IS RECOMMENDED THAT THE ACROVYN COVERS BE CUT SLIGHTLY LONGER (1/32" UP TO 5'-0", 1/16" OVER 5'-0") THAN THE MEASURED DISTANCE. THIS ADDITIONAL LENGTH WILL PROVIDE FOR A TIGHTER COVER-TO-END CAP FIT.

- SNAP THE ACROVYN CRASH RAIL COVER ONTO THE LOWER PORTION OF THE RETAINER. ALIGN THE TOP OF THE ACROVYN HANDRAIL COVER WITH THE TOP OF THE ALUMINUM RETAINER AND SNAP THE COVER ONTO THE RETAINER.
- INSTALL THE END PLATES AT ANY OUTSIDE CORNERS OR END CONDITIONS. SEE PAGE 4 (TYPICAL ASSEMBLY) FOR REFERENCE OF LOCATION OF END PLATES.
- USING THE OUTSIDE PLATE AS A TEMPLATE, MARK THE HOLE LOCATIONS AND DRILL 5/32" PILOT HOLES. INSTALL THE TOP PLATE WITH FOUR (4) #6X 1/2" TAMPER-RESISTANT SHEET METAL SCREWS.
- PLACE A WOOD BLOCK ON TOP OF THE END PLATE. WHILE HOLDING THE END PLATE SOMEWHAT LEVEL, USE A RUBBER Mallet TO STRIKE THE WOOD BLOCK. (**NOTE:** DO NOT HAMMER DIRECTLY ONTO THE END PLATE AS THIS MAY CAUSE DAMAGE TO THE END PLATE).
- CUT THE CONTINUOUS TOP PLATE TO THE PROPER LENGTH BY MEASURING THE DISTANCE BETWEEN THE INSTALLED END PLATES.
- INSTALL THE CONTINUOUS TOP PLATE ONTO THE LIGATURE RESISTANT BRACKET BETWEEN THE INSTALLED END PLATES.
- PLACE A WOOD BLOCK ON TOP OF THE CONTINUOUS TOP PLATE. WHILE HOLDING THE CONTINUOUS TOP PLATE SOMEWHAT LEVEL, USE A RUBBER Mallet TO STRIKE THE WOOD BLOCK. (**NOTE:** DO NOT HAMMER DIRECTLY ONTO THE CONTINUOUS TOP PLATE AS THIS MAY CAUSE DAMAGE TO THE CONTINUOUS TOP PLATE).
- WORK DOWN ALONG THE LENGTH OF THE CONTINUOUS TOP PLATE DRIVING THE TOP PLATE APPROXIMATELY HALF ONTO THE LIGATURE RESISTANT BRACKET. RETURN AND DRIVE THE CONTINUOUS TOP PLATE THE REMAINDER OF THE WAY IN UNTIL THE TOP PLATE IS SEATED FLUSH WITH THE END PLATES.

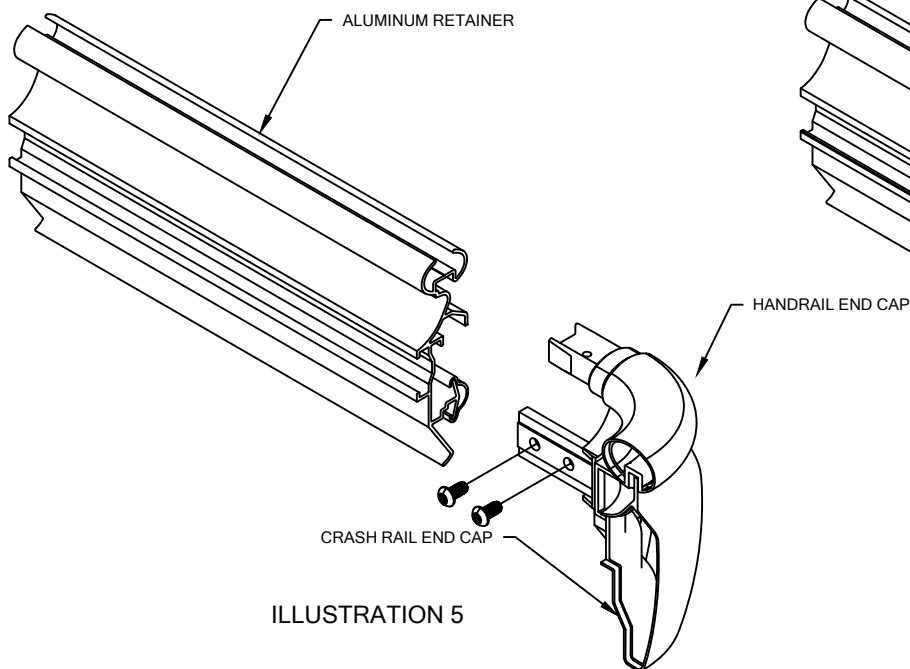

ILLUSTRATION 5

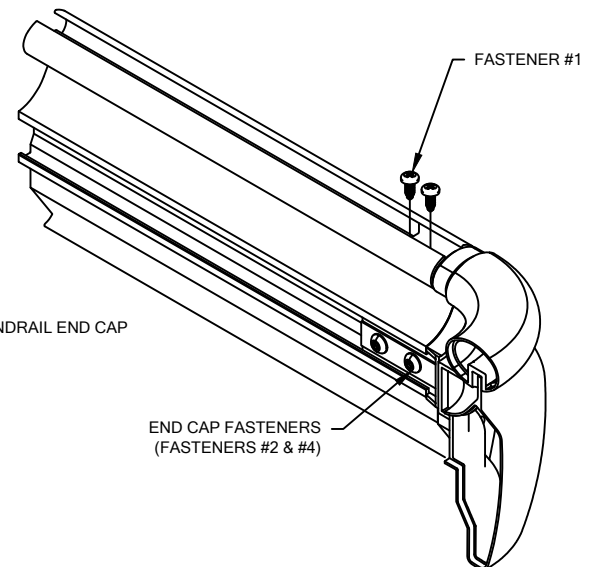

ILLUSTRATION 6

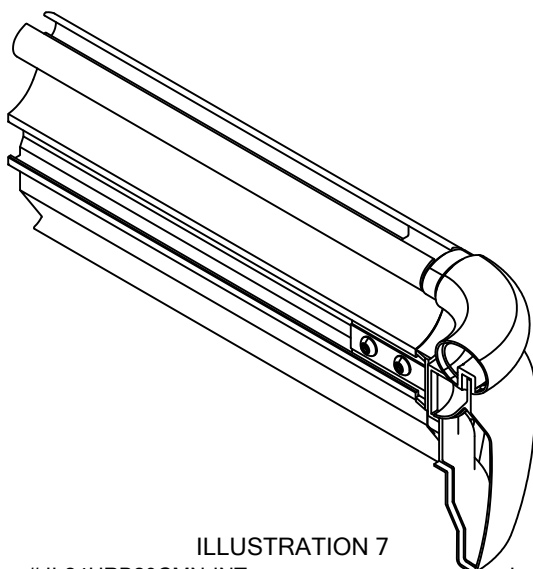

ILLUSTRATION 7

END CAP ATTACHMENT

ATTACH END CAPS/OUTSIDE CORNERS TO THE RETAINER BY LOOSELY THREADING TWO (2) 1/4-20 X 1/2" BUTTON SOCKET HEAD CAP SCREWS THROUGH THE BACKSIDE OF THE FLANGE OF EACH END CAP (FOUR (4) PER CORNER ASSEMBLY) INTO THEIR RESPECTIVE NUTS ON THE RETAINER SIDE OF THE FLANGE. SLIDE THE FLANGE INTO THE RECEIVER CHANNEL OF THE ALUMINUM RETAINER AND TIGHTEN THE BUTTON SOCKET HEAD CAP SCREWS FOR A SECURE FIT.

HRB-20CMN HANDRAIL

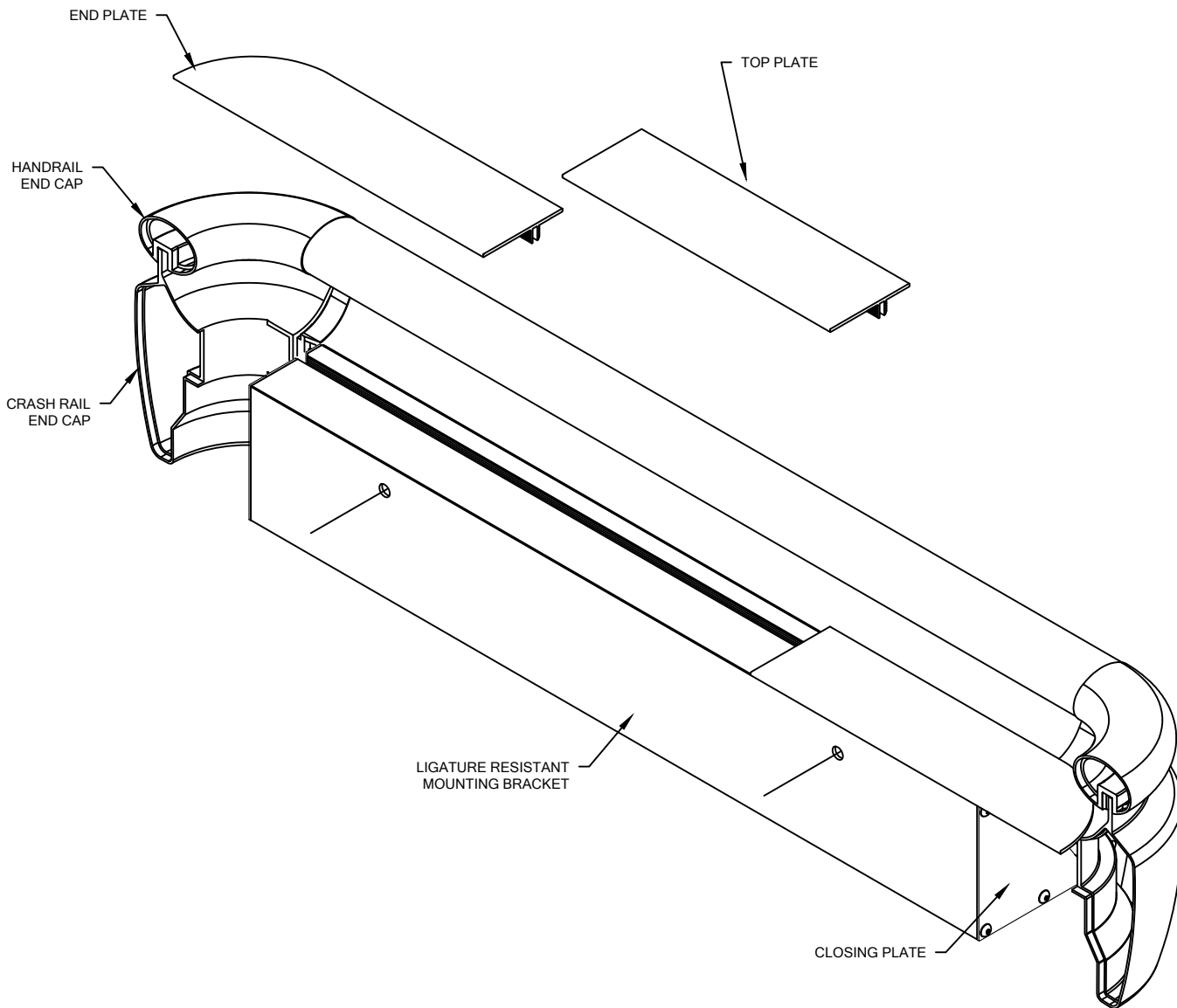

ILLUSTRATION 8