

MODEL ALSW/ALRW-100 THRU 400 INSTALLATION INSTRUCTIONS

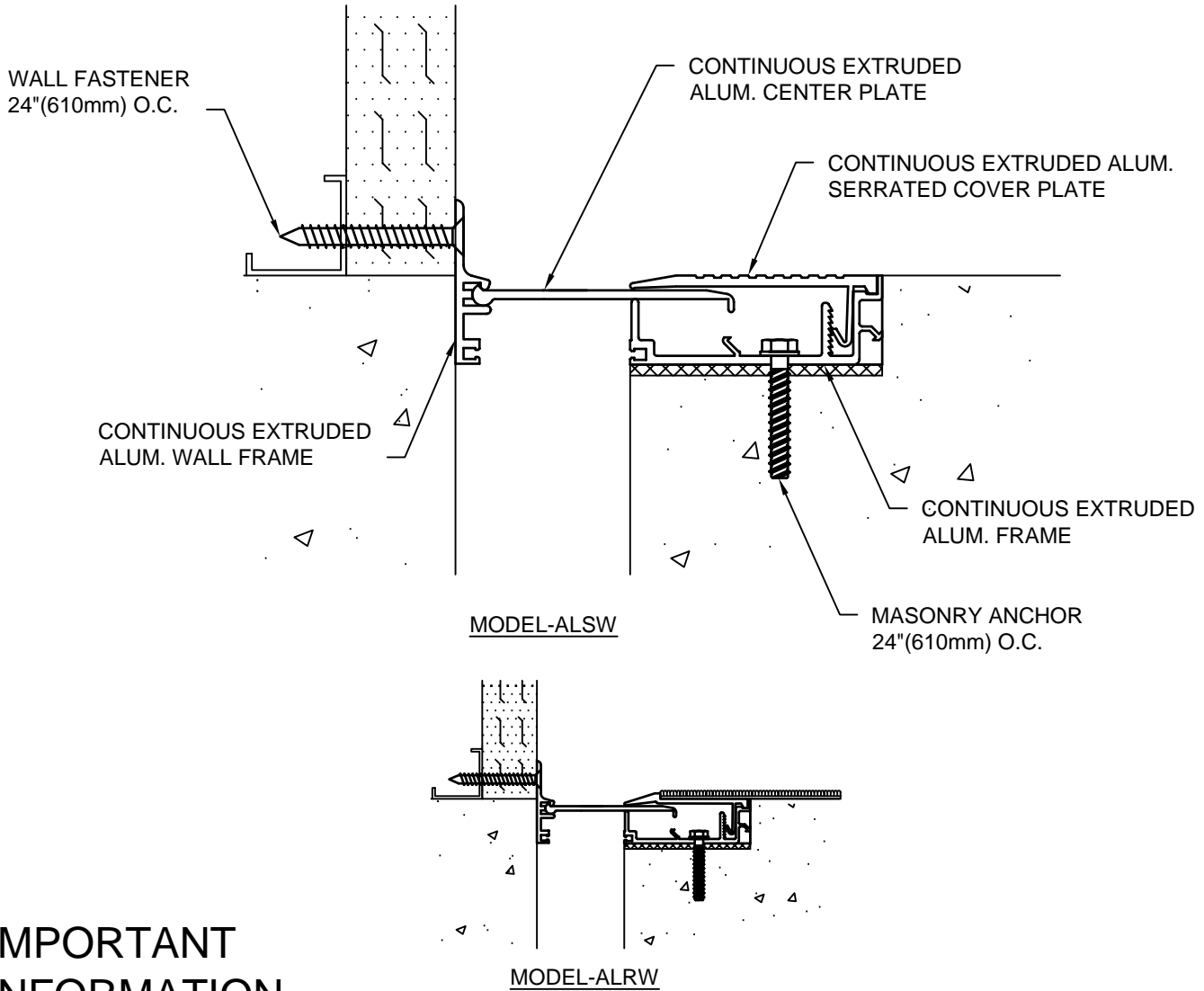

IMPORTANT INFORMATION

Prior to the commencement of Installation, all materials MUST be inspected for Damage. Any damage must be reported to CONSTRUCTION SPECIALTIES, INC., as soon as possible, so that replacement materials may be furnished without delay.

All work must be completed as per Architect's Approved "Shop Drawings", and in accordance with these Installation Instructions. When installation is complete, all materials must be protected from damage until the Architect's FINAL INSPECTION.

All materials should be arranged in the order that they are to be installed. All hardware required for each portion of the work should be placed with the appropriate materials.

Please review all Approved Shop Drawings and this Document to familiarize yourself with all the details and components of this assembly.

IMPORTANT:
READ THROUGH ALL INSTRUCTIONS PRIOR TO STARTING INSTALLATION

10/17/05

CONSTRUCTION SPECIALTIES, INC.

P.O. BOX 380
MUNCY, PA 17756
PHONE: (570)546-5941 FAX: (570)546-8022

This document is the property of Construction Specialties, Inc. and contains CONFIDENTIAL PROPRIETARY INFORMATION that is not to be disclosed to third parties and is not to be used without approval in writing from Construction Specialties, Inc.

Notes:

Before beginning installation, review the architectural drawings and approved Construction Specialties Inc. shop drawings to familiarize yourself with the appropriate joint cover models and locations.

Check all of the joint cover components to confirm that the correct joint cover model and size have been received. Also, check for materials that may have been damaged during shipping. Report all incorrect and/or damaged components to C/S at 800-233-8493.

Read through all the steps of these instructions prior to beginning work.

STEP 1

PREPARE BLOCKOUTS

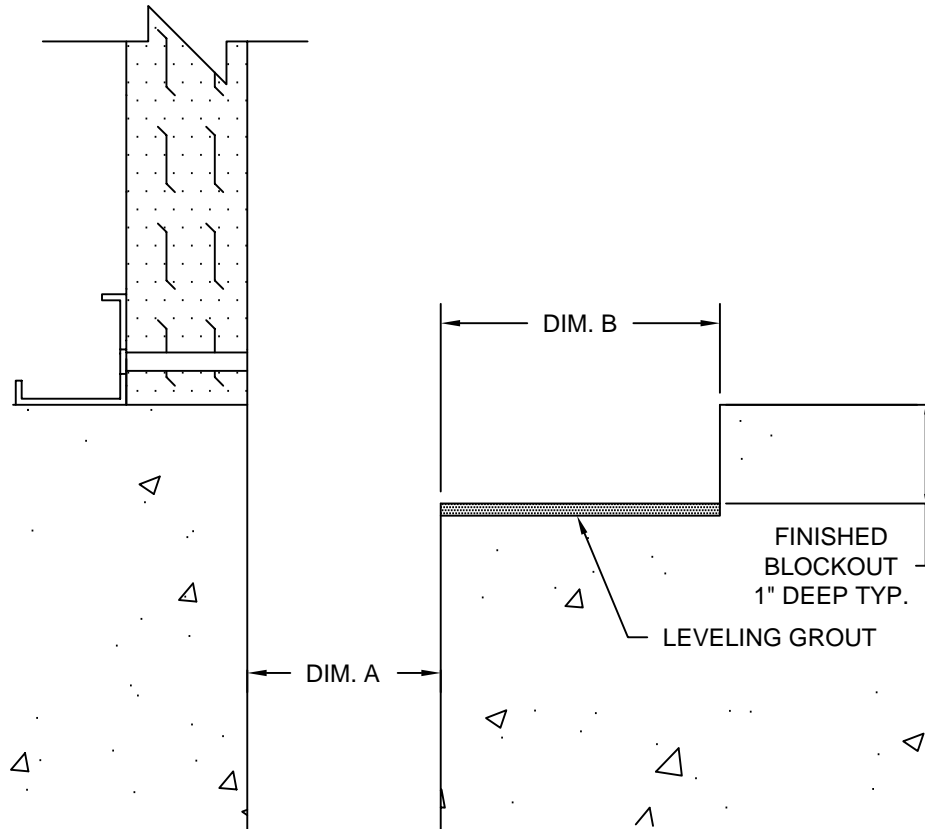

BLOCKOUT DIMENSIONS	
DIM. A	DIM. B
1" [25.4mm]	2" [50.8mm]
2" [50.8mm]	2-7/8" [73.025mm]
3" [76.2mm]	3-7/8" [98.425mm]
4" [101.6mm]	3-7/8" [98.425mm]

- 1.1) The blockouts must be prepared to receive the joint cover.
 - The blockout width (Dim. B) will vary by model as indicated above or as noted on the C/S shop drawings.
 - For model ALSW, the blockout depth may be adjusted as needed to accommodate a floor finish material when required and as indicated on the architectural drawings and/or C/S shop drawings.
 - For model ALRW, the blockout depth is to be 1" (25.4mm). It is recommended that the blockout be formed a minimum of 1/8" deeper to allow the blockouts to be leveled for installation of the joint cover.
 - Apply a high-strength leveling grout to the base of the blockouts to provide a continuous, solid, flat and level base for the joint cover. (Note: The blockouts must be level across the width of the joint.)

STEP 2

FRAME INSTALLATION

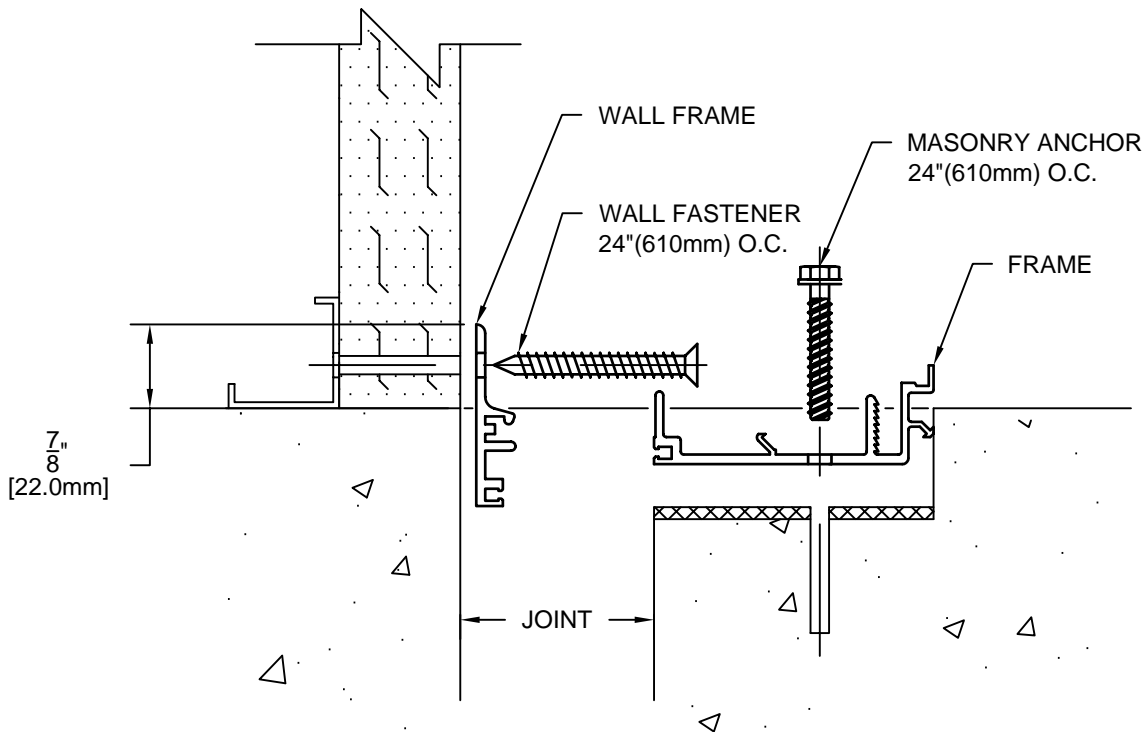

Note:

If a C/S Fire Barrier is to be installed in the joint, please review the Fire Barrier Installation Instructions supplied, and if required install the Fire Barrier **BEFORE** installation of C/S Seismic Expansion Joint aluminum frames. If a Waterstop is to be installed in the joint, please review the Waterstop Installation Instructions supplied, and if required install the Waterstop **BEFORE** installation of C/S Seismic Expansion Joint Aluminum Frames.

- 2.1) Begin installation of the Frame by placing a length of Frame into the blockout. Cut the Frame to length as needed. The Frame is to sit level, flat and parallel to the edge of the joint. The Frame should not overhang the edge of the slab or sit above the top surface of the slab.
- 2.2) Using the Frame as a template, mark the locations in the blockout for the anchor bolts. Remove the Frame and drill the holes for the anchor bolts. The holes are to be drilled with the appropriate size and type of drill bit as indicated by the manufacturer of the anchor bolts, as supplied by C/S.
- 2.3) Reposition the Frame and anchor the Frame to the slab with the C/S supplied anchor bolts following the manufacturer's guidelines.
- 2.4) Repeat the installation procedures for any additional lengths of Frame.
- 2.5) The Wall Frame attaches directly to the face of the wall adjacent to the joint.
- 2.6) Measure 7/8"(22.2mm) above the top rear surface (highest point) of the Wall Frame and mark a line on the wall surface.
- 2.7) Align the top of the Wall Frame with the line on the wall surface. Mark and drill holes (if needed) for the appropriate wall fasteners using the Frame as a template.
- 2.8) Attach the Wall Frame with the C/S supplied wall fasteners.
- 2.9) Repeat the installation procedures for additional lengths of Wall Frame as needed.

STEP 3

CENTER PLATE INSTALLATION

WALL FASTENER
24"(610mm) O.C.

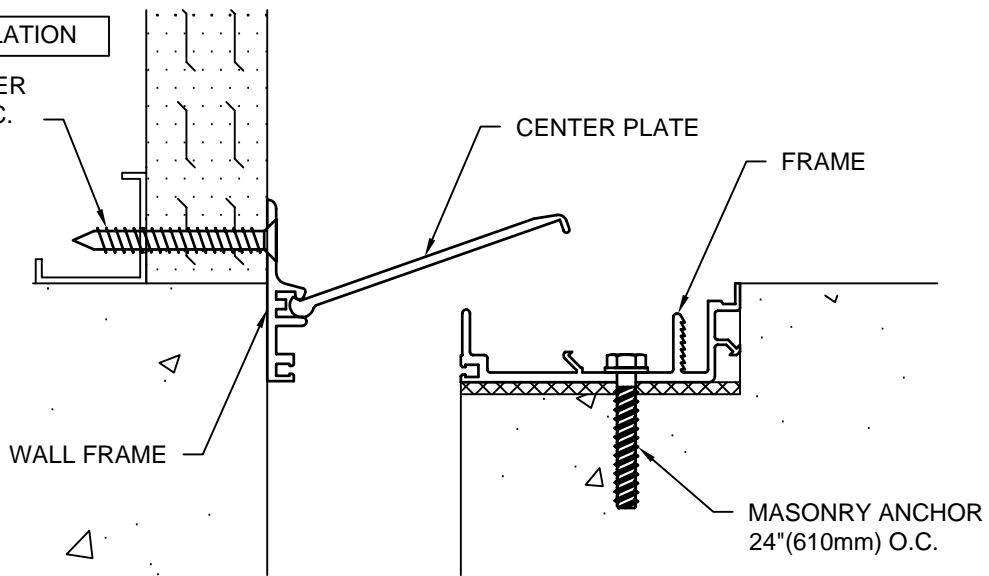

3.1) Install the Center Plates by holding the Plate at approx. 45° angle and insert the hinge end of the Center Plate into the slot of the Wall Frame. Then rotate the Center Plate down to rest on the Frame.

STEP 4

COVER PLATE INSTALLATION

WALL FASTENER
24"(610mm) O.C.

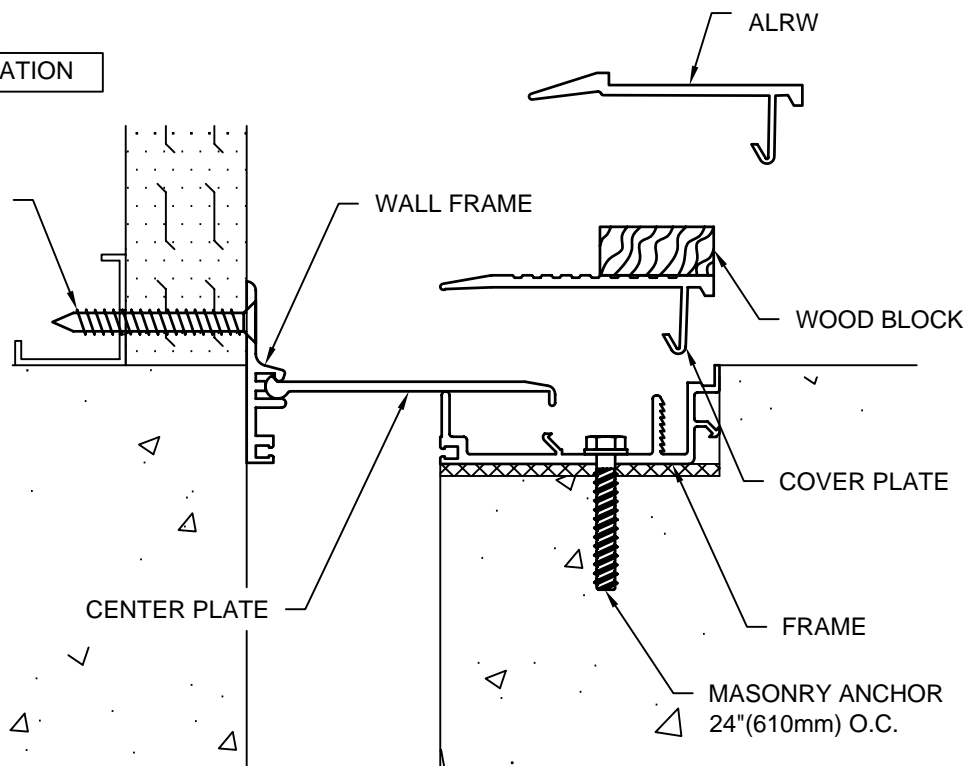

4.1) Begin installation of the Cover Plates by aligning one end of a length of Cover Plate with the end of the installed Frame. Align the "J-Hook" on the underside of the Cover Plate with the locking channel of the Frame.

4.2) Place a wood block on top of the Cover Plate over the "J-Hook" area. While holding the Cover Plate somewhat level, use a rubber mallet to strike the wood block and drive the "J-Hook" into the locking channel. (Note: Do not hammer directly onto the Cover Plates as this may cause damage to the Cover Plate.)

4.3) Work down along the length of the Cover Plate driving the "J-Hook" approx. half way in. Then return and drive the Hook the remainder of the way in until the Cover Plate is seated against the Frame.

4.4) Repeat these procedures for any additional lengths of Cover Plate.

STEP 5

COMPLETE INSTALLATION

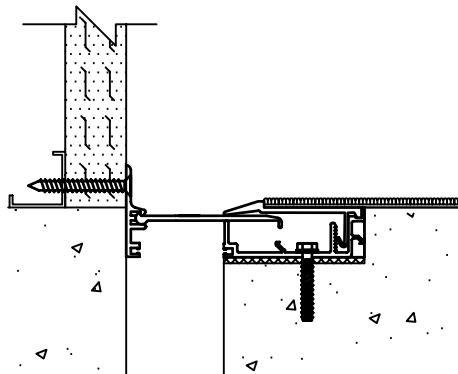
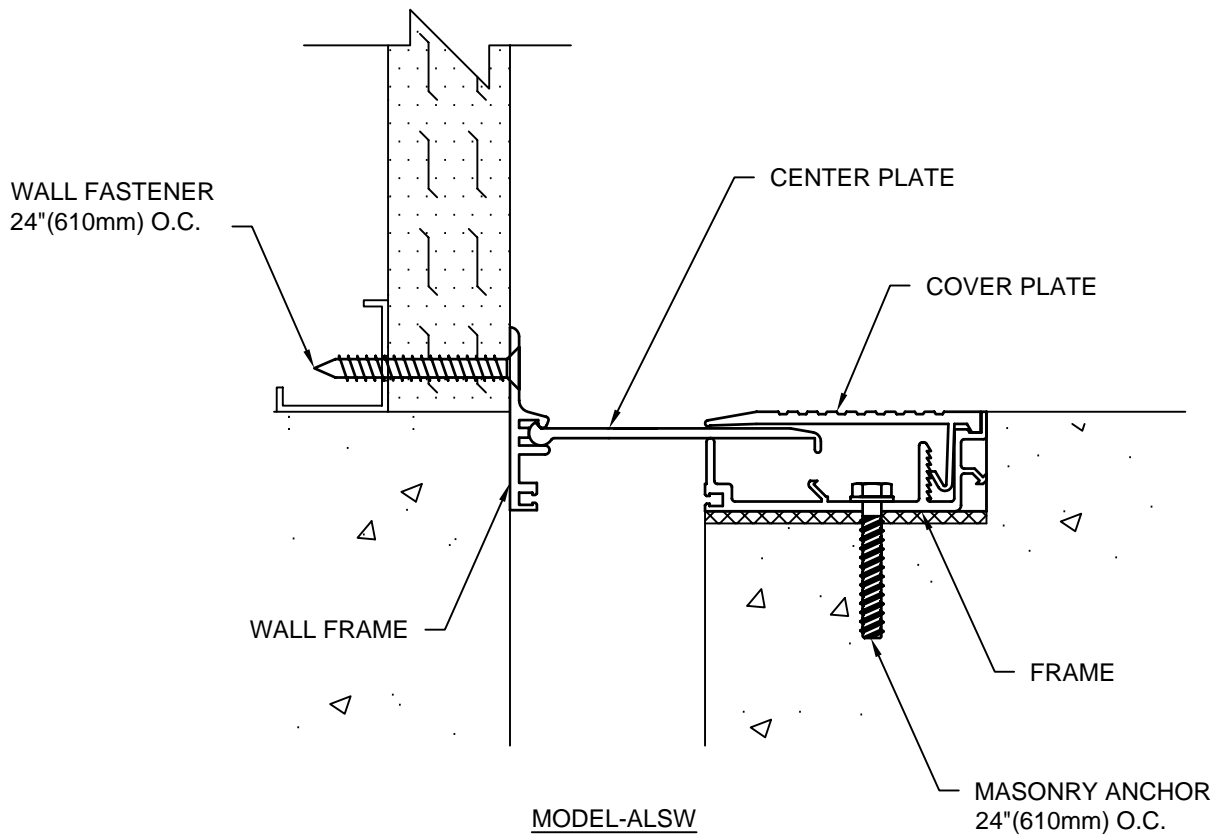

- 5.1) When installation of the C/S Floor Expansion Joint Cover has been completed, remove all residue and foreign matter from the area and joint cover.
- 5.2) Clean the C/S Joint Cover and the adjoining surface with proper cleaner.
- 5.3) Protect the Joint Cover until the Architect's final inspection.