

ATTENTION

Please read these instructions thoroughly prior to beginning the **HRBW-10CQLN HANDRAIL** installation.

This instruction sheet is intended to provide a specific guide to follow for the installation of the **HRBW-10CQLN HANDRAIL**. Contained within is the technical information and installation techniques required to complete an efficient, neat, and long-lasting installation.

See "**HANDRAIL**- Supplemental Information" sheet for additional notes and other helpful installation tips.

Minimum length of **HRBW-10CQLN HANDRAIL** is 15-3/4" [400.3mm] and requires at least 2 brackets per unit.

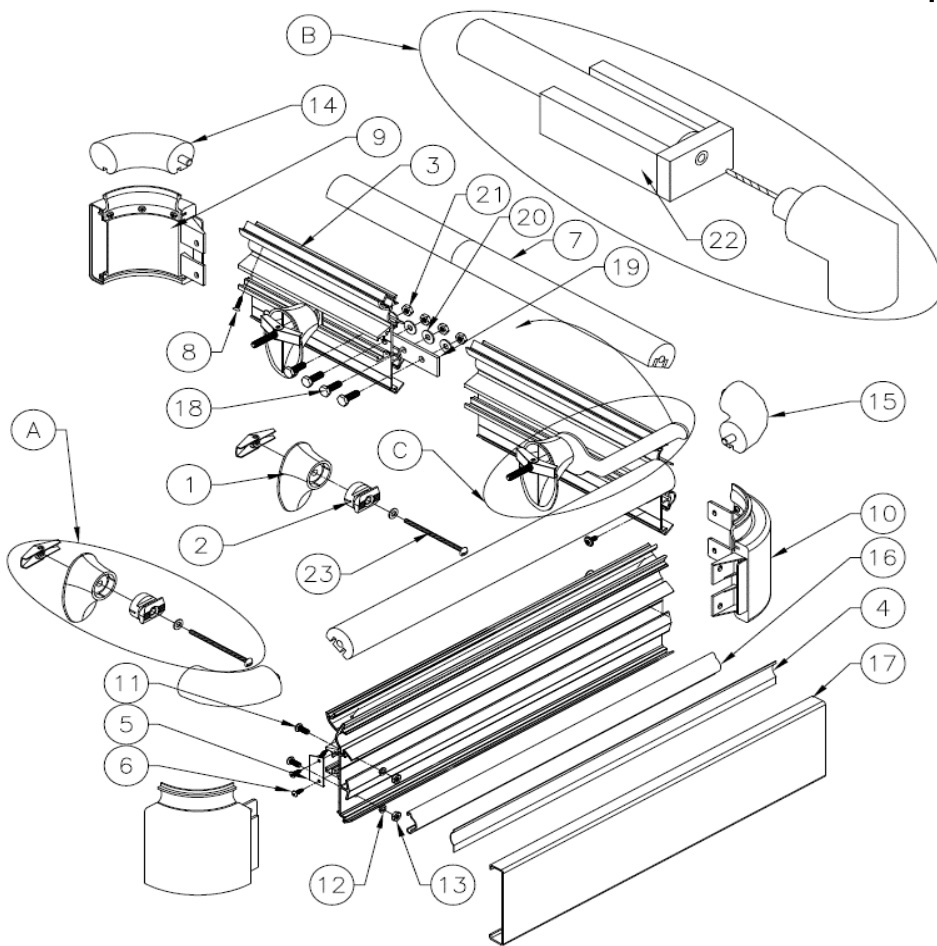
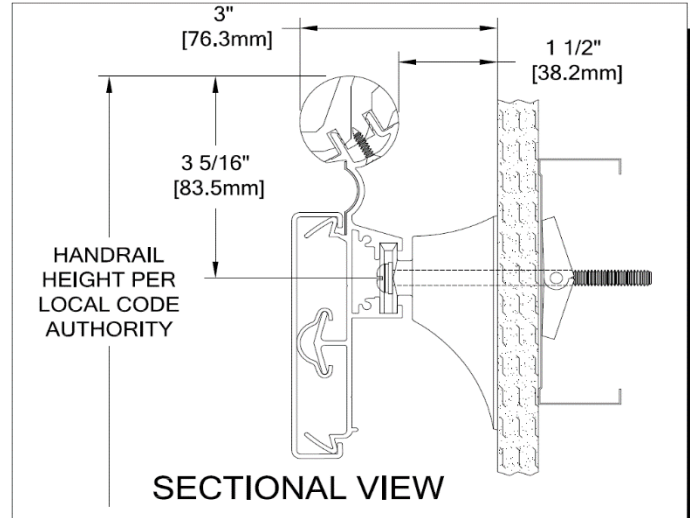

Parts List

1. Mounting Bracket (24I820xxx)
2. Quick Lock
 - a. Standard (24I821000)
 - b. Metal (for OSHPD) (24M068000)
3. Aluminum Retainer (24A369000)
4. Acrovyn Accent Reveal (24N021xxx)
5. 10C Quick Lock Retainer End Plate (24F254004)
6. #6 x 1/2" Phillips Pan Head Sheet Metal Screw (90H255002)
7. Wood Handrail (24W001xxx)
8. #6 x 5/8" Phillips Flat Head SMS (90H231002)
9. Crash Rail End Cap Assembly
10. Crash Rail Outside Corner Assembly
11. #10-24 x 1/2" Round Head Slotted Machine Screw (90H369002)
12. #10 Lock Washer (90H370002)
13. #10 Hex Nut (90H368002)
14. Wood Handrail End Cap
 - a. Right Hand (24W012xxx)
 - b. Left Hand (24W013xxx)
15. Wood Handrail Outside Corner (24W019xxx)
16. RC-10 Cushion (24U952108)
17. Acrovyn Crashrail Cover
 - a. Solid Color (24U009xxx)
 - b. Chameleon Color (24U616xxx)
18. 1/4-20 x 1/2" Hex Head Machine Screw (90H052002)
19. Retainer Splice Bar (24I976000)
20. 1/4" Lock Washer (90H006003)
21. 1/4-20 Hex Nut (90H010010)
22. Wood Handrail Drill Jig (90H110010)
23. Specified Fastener (see table on bottom of page 2)
24. #4 x 1/2" HSS Countersink Drill (90H035010)

Hughesville, PA | 800.233.8493 | 570.546.5941
 Mississauga, ON | 888.895.8955 | 905.274.3611

www.c-sgroup.com
IWPTechSupport@c-sgroup.com

INSTALLATION INSTRUCTIONS

1. Establish handrail height above finish floor. Deduct 3-5/16" [83.6mm] and snap a chalk line at that height to mark the locations of the fasteners for the handrail brackets.
2. Determine wall fastener locations by using the required deductions (see layout view) and drill hole diameter for specified wall fasteners. Reference chart below for correct drill diameters.
3. Place a quick lock into each bracket base. Use the appropriate fasteners and attach the bracket assemblies to the wall at the pre-drilled locations. See figure "A" callout on page 1.
4. Cut the continuous aluminum retainer to length using the required deductions as noted (see layout view).
5. Mark fastener locations along v-groove on back of retainer (see sectional view). Fasteners start 2" [50.8mm] from the ends of the retainer and are 24" [609.6mm] on center. Use the supplied countersinking drill for holes along v-groove where wood handrail fastens to retainer.
6. Cut accent reveal to length and insert into slot proved in the top section of the aluminum retainer.
7. Where the retainer will have an end cap / outside corner, attached the 10C Quick Lock retainer end plate to the retainer using two (2) #6 x 1/2" sheet metal screws
8. Cut wood top rail to exact length of retainer. See figure "B" call out on page 1 for drilling cut end of rail. Bevel the cut edges on handrail end slightly with 150 grit sandpaper to match bevel on wood end caps. Touch up sanded edges with stain marker. Using the holes in the aluminum retainer as a guide, drill 3/32" diameter pilot holes 3/8" dep into the wood handrail. Attach the top rail to the retainer using the #6 x 5/8" Phillips flat head sheet metal screws.
9. Attach all end caps / outside corners:
 - a. Attach crash rail portion of end cap to the retainer:
 - i. Use end cap as template to drill 7/32" pilot holes in retainer.
 - ii. Attach end cap / outside corners by sliding the end cap onto the end of the aluminum retainer and securing into position using two (2) #10-24 x 1/2" round head slotted machine screw with lock washer and #10 hex nut at each end cap and four (4) at each outside corner.

NOTE: Solid portion of outside corner flange mounts to the back of the retainer while the split flange mounts to the inside of the retainer.

- b. Attach handrail portion of end cap to retainer:
 - i. Slide the end cap dowel into the alignment hole in the rail. Wood glue must be applied to the dowel prior to insertion.
 - ii. Apply hot melt glue (not supplied) on the reverse side of the end cap where the adaptor fits into the bottom groove of the top cap.

NOTE: To aid in locating the crash rail end caps correctly, cut a 4" [101.6mm] section of cover from scrap and snap it on the retainer. Locate the cap so it aligns flush with the top and bottom of the cover.

10. Place the retainer on the wall brackets so that the head of each quick lock inserts into the channel on the back of the retainer. Using the wrench provided, twist each lock 90° to secure the bracket base into place. See figure "C" callout on page 1. Use a level to ensure retainer is level.
11. Cut RC-10 cushion to length noting required deductions (see layout view) and install onto aluminum retainer.
12. Cut Acrovyn crash rail cover to length. The cover length is determined by measuring the distance between the installed end caps and / or outside corner assemblies.
13. Complete installation by installing the Acrovyn crash rail cover onto the lower portion of the retainer.

WALL CONDITION	SPECIFIED FASTENER	DRILL DIAMETER		CS PART NUMBER
		WALL	RETAINER	
Steel Stud / Gypsum Wall	1/4-20 x 5" Round Head bolt with Toggle Lock Washer	3/4"	N/A	90H049002 90H006003
Concrete / Concrete Block	#14 x 5" Phillips Round Head All-Purpose Screw	3/16"	N/A	90H287002
Wood Stud / Gypsum Wall	#14 x 5" Phillips Round Head All-Purpose Screw	1/8"	N/A	90H287002

Hughesville, PA | 800.233.8493 | 570.546.5941
 Mississauga, ON | 888.895.8955 | 905.274.3611

www.c-sgroup.com
IWPTechSupport@c-sgroup.com

