

COLOR: _____
 HANDRAIL WOOD SPECIES: _____
 HANDRAIL WOOD FINISH: _____
 COLOR TO BE SELECTED FROM ONE OF C/S STANDARD COLORS.

TOTAL L/F REQ'D	LEFT END CAPS	RIGHT END CAPS

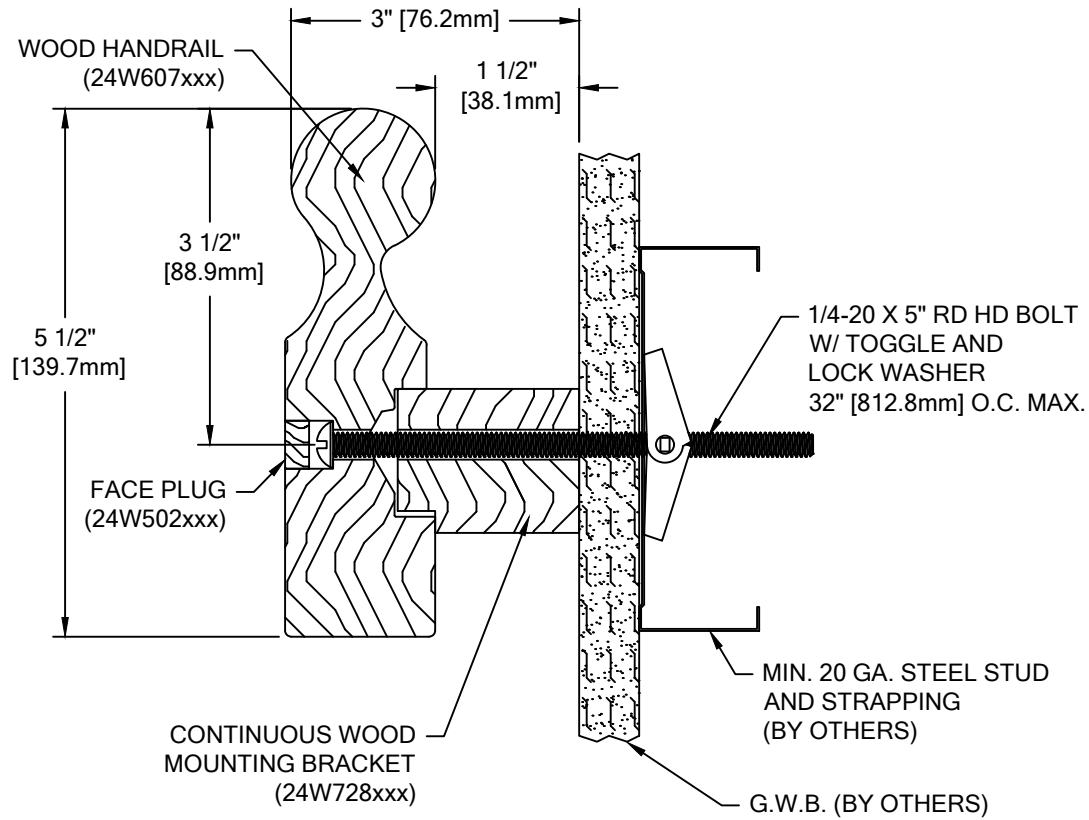

AW-10CCB

FABRICATION AND APPEARANCE OF THIS WOOD RAIL MATERIAL IS BASED ON FACTORY CUT AND ATTACHED END CAPS. IF STOCK SIZES ARE REQUIRED, END CAPS MUST BE CUT IN THE FIELD BY INSTALLER OR C/S WILL NOT GUARANTEE MATCH AND APPEARANCE OF CAPS TO RAIL.

WALL CONDITION	SPECIFIED FASTENER	DRILL DIAMETERS		C/S PART NUMBER
		WALL	RETAINER	
STEEL STUD/GYPSUM WALL	1/4-20 X 5" ROUND HEAD BOLT WITH TOGGLE, AND LOCK WASHER	3/4"	9/32"	90H049002 90H006003
CONCRETE/CONC. BLOCK	#14 X 5" PHILLIPS RD HD ALL-PURPOSE SCREW	3/16"	9/32"	90H287002
WOOD STUD/GYPSUM WALL	#14 X 5" PHILLIPS RD HD ALL-PURPOSE SCREW	1/8"	9/32"	90H287002

 <p>Construction Specialties™ 6696 Route 405 Highway, Muncy PA 17756 (800) 233-8493 • Fax (570) 546-4692 • www.c-sgroup.com</p>	PROJECT:	REVISION:
	JOB NO.:	F&F:
	CUSTOMER:	
	REP:	DATE:
	DRAWN BY:	SHEET NO: