

COLOR:
 *TOP RAIL: _____
 BOTTOM RAIL WOOD SPECIES: _____
 BOTTOM RAIL WOOD FINISH: _____
 *BRACKETS: _____
 COLOR TO BE SELECTED FROM ONE OF CS STANDARD COLORS.
 *TOP RAIL/CAPS/CORNERS/BRACKETS ARE AVAILABLE WITH AN OPTIONAL POWDER COAT FINISH. PLEASE ADVISE POWDER COAT FINISH IF REQUIRED.

TOTAL L/F REQ'D	END CAPS	O.S. REQ'D

NOTE: STAINLESS STEEL CORNERS OTHER THAN 90° ARE UNAVAILABLE FOR THIS MODEL. THIS MODEL IS FABRICATED CUT-TO-SIZE, THEREFORE FIELD VERIFIED DIMENSIONS ARE REQUIRED.

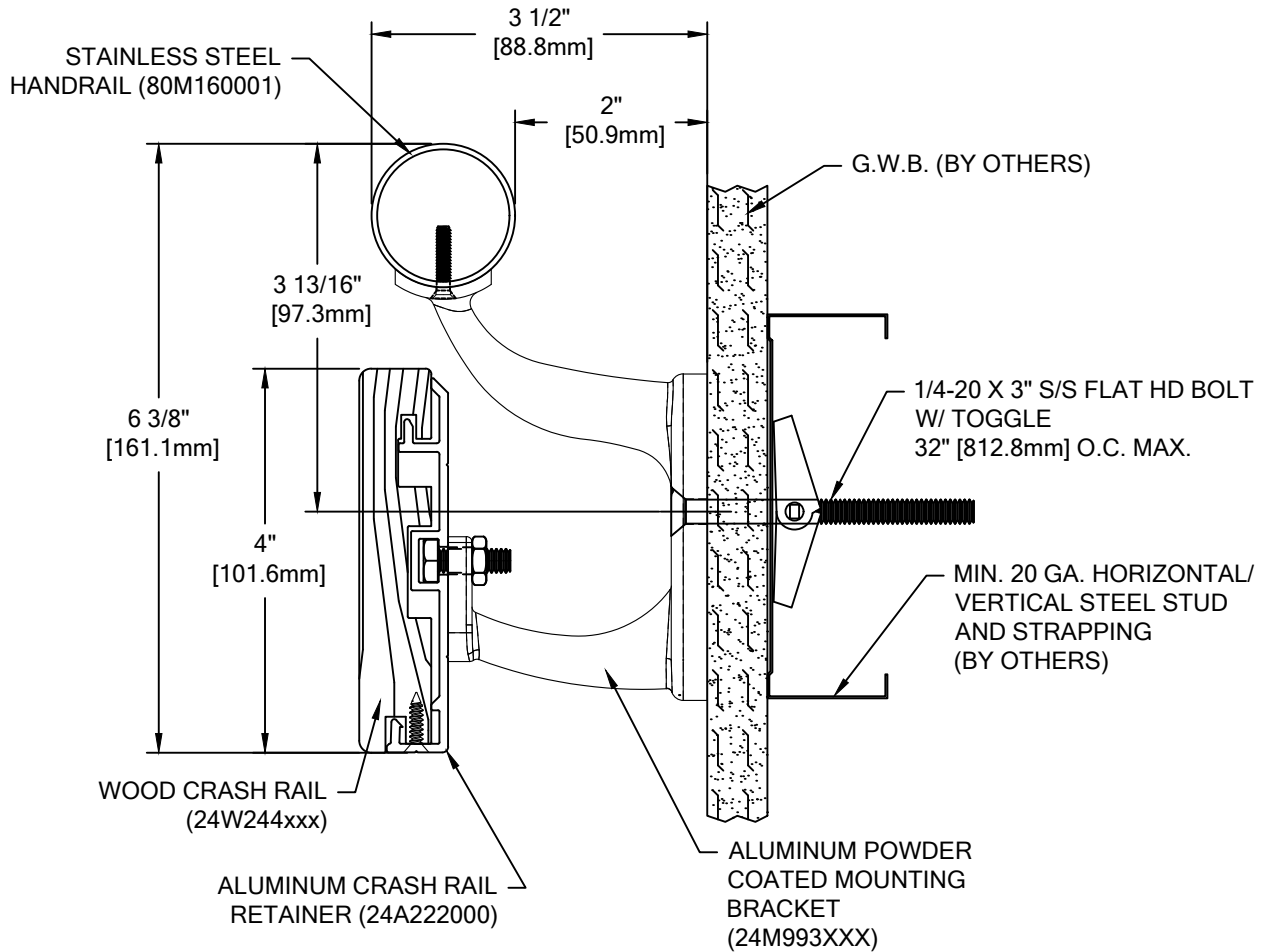

P-RSW-INT

WALL CONDITION	SPECIFIED FASTENER	DRILL DIAMETERS		CS PART NUMBER
		WALL	RETAINER	
STEEL STUD/GYPSUM WALL	1/4-20 X 3" S/S FLAT HEAD BOLT WITH TOGGLE	3/4"	N/A	90H184002
CONCRETE/CONC. BLOCK	1/4" X 1 3/4" S/S FLAT HEAD MASONRY ANCHOR	3/16"	N/A	90H390000
WOOD STUD/GYPSUM WALL	#14 X 3" S/S PHILLIPS FLAT HEAD WOOD SCREW	7/32"	N/A	90H538004

 Hughesville, PA 800.233.8493 570.546.5941 Mississauga, ON 888.895.8955 905.274.3611 www.c-sgroup.com © Copyright 2017 Construction Specialties, Inc.	PROJECT:	REVISION:
	JOB NO.:	F&F:
	CUSTOMER:	
	REP:	DATE:
	DRAWN BY:	SHEET NO: