

P-RAWN / GN / VN HANDRAIL
 WITH INTERNATIONAL OFFSET
PLEASE READ

PLEASE READ THESE INSTRUCTIONS THOROUGHLY PRIOR TO BEGINNING THE P-RAWN / GN / VN-INT HANDRAIL INSTALLATION!

THIS INSTRUCTION SHEET IS INTENDED TO PROVIDE A SPECIFIC GUIDE TO FOLLOW FOR THE INSTALLATION OF THIS P-RAWN / GN / VN-INT HANDRAIL. CONTAINED WITHIN IS THE TECHNICAL INFORMATION AND INSTALLATION TECHNIQUES REQUIRED TO COMPLETE AN EFFICIENT, NEAT AND LONG-LASTING INSTALLATION.

INSPECT ALL MATERIALS FOR DAMAGE OR MISSING PARTS. IF YOU DISCOVER DAMAGED OR MISSING MATERIALS, IN THE USA PLEASE NOTIFY THE FACTORY AT (800) 233-8493, AND IN CANADA (888) 895-8955 FOR CUSTOMER SERVICE.

P-RAWN / GN / VN-INT HANDRAIL MUST BE INSTALLED IN ACCORDANCE WITH THESE INSTRUCTIONS! FAILURE TO FOLLOW THESE INSTRUCTIONS MAY VOID ANY PRODUCT WARRANTIES AND RESULT IN AN UNSUCCESSFUL INSTALLATION. FOR SPECIFIC QUESTIONS REGARDING THE INSTALLATION OF THIS P-RAWN / GN / VN-INT HANDRAIL PLEASE CALL THE FACTORY IN THE USA AT (800) 233-8493 OR EMAIL IWPTECHSUPPORT@C-SGROUP.COM. IN CANADA CALL (888) 895-8955.

IMPORTANT NOTES

1. DUE TO WOOD BEING A NATURAL PRODUCT, COMPONENTS MAY GROW AND SHRINK AT DIFFERENT RATES. BECAUSE OF THIS, CS HAS DESIGNED THIS HANDRAIL TO UTILIZE A BEVEL AS SHOWN IN THESE INSTRUCTIONS (SEE FIGURE 1). THIS BEVEL MUST BE APPLIED AT ALL WOOD JOINTS AND MUST MATCH FACTORY BEVEL ON END CAPS.
2. DUE TO THE NATURE OF WOOD, COMPONENT COLORS MAY VARY. SORT WOOD COMPONENTS AND MATCH PARTS BY COLOR.
3. ALL LINEAL MATERIAL TO BE SUPPLIED IN STOCK LENGTHS. WOOD IN 7'-0" TO 12'-0" VARIABLE, AND ALUMINUM AND ACRYLYN IN LENGTHS UP TO 20'-0". THIS MATERIAL IS TO BE FIELD CUT USING QUALITY EQUIPMENT TO INSURE THAT ALL CUTS ARE SQUARE. WHEN CUTTING MATERIAL SECTIONS, CS RECOMMENDS USING AN 80-100 TOOTH CARBIDE TIPPED SAW BLADE OR EQUIVALENT, TO MINIMIZE CHIPPING AND MAINTAIN JOINT ALIGNMENT.
4. ALL DIMENSIONS ARE TYPICAL.
5. FOR DRYWALL/PLASTER WALL CONSTRUCTION, IT IS RECOMMENDED FOR FASTENERS TO BE ENGAGED INTO METAL/WOOD STUDS TO MAINTAIN MAXIMUM PULLOUT STRENGTH. IF DURING INSTALLATION YOU ENCOUNTER SPECIAL WALL CONDITIONS THAT DO NOT ALLOW FOR DIRECT ATTACHMENT TO THE STUDS PLEASE CONSULT THE LOCAL AUTHORITY HAVING JURISDICTION.
6. INSTALL OUTSIDE CORNERS FIRST.
7. INSTALL LONGEST RUN OF HANDRAIL FIRST.
8. ALUMINUM RETAINER SPLICE SHOULD NOT EXCEED 3" [76.2mm] DISTANCE FROM A BRACKET.
9. THE DISTANCE BETWEEN A WOOD/ACROVYN SPLICE JOINT AND AN ALUMINUM RETAINER SPLICE JOINT SHOULD NOT BE LESS THAN 12" [304.8mm].
10. MATERIAL MUST REACH 65°F MIN. TO 75°F MAX. 24 HOURS PRIOR TO INSTALLATION. THIS IS ESSENTIAL TO MINIMIZE EXPANSION AND CONTRACTION OF MATERIAL.
11. MAY REQUIRE USE OF FIRE PUTTY WHEN INSTALLED ON FIRE WALL WITH TOGGLE BOLTS. REFERENCE INSTRUCTIONS 24FIREPUTTY FOR FIRE PUTTY INSTALLATION.
12. THIS HANDRAIL REQUIRES A MINIMUM OF 2 MOUNTING BRACKETS PER UNIT. THE MINIMUM END CAP-TO-END CAP HANDRAIL LENGTH IS 13 1/4" [335.6mm].
13. FOR MORE INFORMATION ON P-RAWN HANDRAIL SEE OUR WEBSITE AT www.c-sgroup.com.

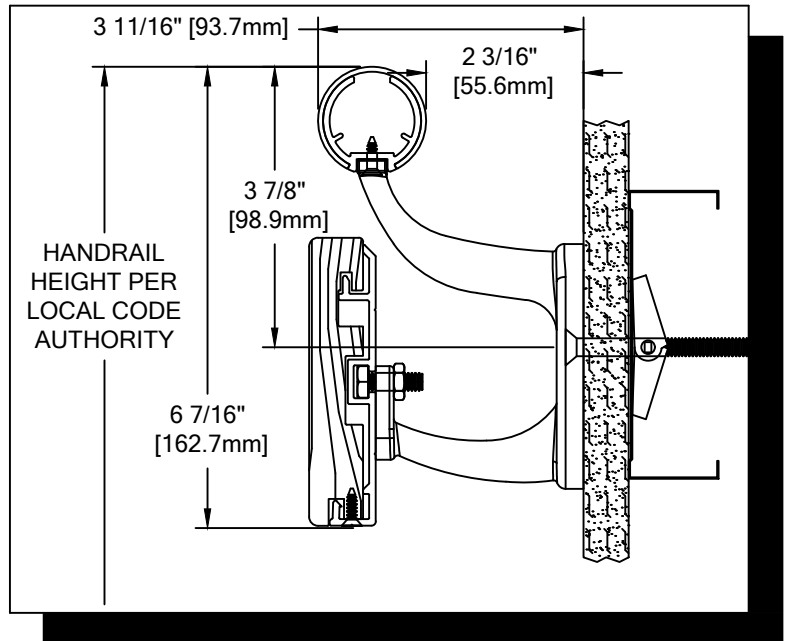

SECTIONAL VIEW
 *P-RAWN-INT SHOWN SEE PAGE 4
 FOR P-RAWVN-INT AND P-RAWGN-INT

**P-RAWN / GN / VN HANDRAIL
WITH INTERNATIONAL OFFSET**

COMPONENTS & WALL FASTENERS



WOOD CRASH RAIL
(24W244xxx-PLAIN) FOR P-RAWN
(24W251xxx-GROOVED) FOR
P-RAWGN & P-RAWVN



ALUMINUM CRASH
RAIL RETAINER
(24A222000)



ACROVYN HANDRAIL COVER
(24U032xxx)
ACROVYN CHAMELEON COVER
(24U610xxx)



ALUMINUM HANDRAIL
RETAINER
(24A095000)

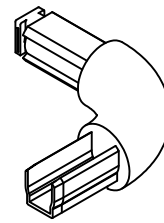

HANDRAIL OUTSIDE
CORNER ASSEMBLY

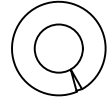

FASTENER #1
1/4" LOCK WASHER
(90H006003)

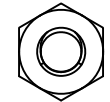

FASTENER #2
1/4-20 HEX NUT
(90H010001)

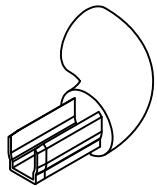

HANDRAIL END CAP
(24I082xxx, LH)
(24I083xxx, RH SHOWN)
CHAMELEON END CAP
(24I610xxx, LH)
(24I634, RH)

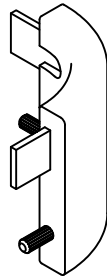

WOOD CRASH RAIL
OUTSIDE CORNER
(24W248xxx-PLAIN)
(24W255xxx-GROOVED)

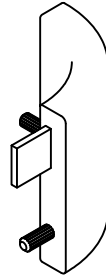

WOOD CRASH RAIL END CAP
(24W246xxx-RH PLAIN, SHOWN)
(24W253xxx-RH GROOVED)
(24W245xxx-LH PLAIN)
(24W252xxx-LH GROOVED)

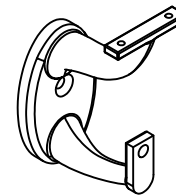

STAINLESS STEEL
MOUNTING BRACKET
(24S171000)
OPTIONAL ALUMINUM
POWDER COATED
BRACKET
(24M994XXX)



FASTENER #3
#6 X 5/8" S/S PHILLIPS
FLAT HEAD SMS
(90H231004)

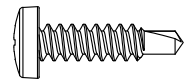

FASTENER #4
#10 X 3/4" PHILLIPS S/S
PANHEAD TEK SCREW
(90H739006)

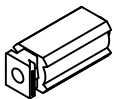

ALIGNMENT PLUG
(24I051000)

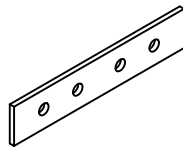

CRASH RAIL
RETAINER SPLICE BAR
(24I976000)

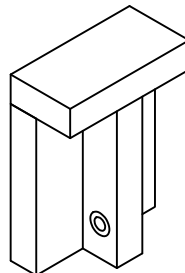

DOWEL PIN
DRILLING JIG
(90H153010)



OPTIONAL FEATURE INSERT
(24V011xxx)

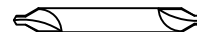

#4 X 1/2" HSS
COUNTERSINK DRILL
(90H035010)

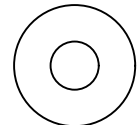

FASTENER #5
1/4" FLAT WASHER
(90H007003)

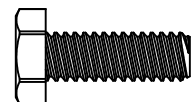

FASTENER #6
1/4-20 X 3/4" S/S HEX HEAD
MACHINE SCREW
(90H008006)

WALL CONDITION	SPECIFIED FASTENER	DRILL DIAMETERS		CS PART NUMBER
		WALL	RETAINER	
STEEL STUD/GYPSUM WALL	1/4-20 X 3" S/S FLAT HEAD BOLT WITH TOGGLE	3/4"	N/A	90H184002
CONCRETE/CONCRETE BLOCK	1/4" X 1 3/4" S/S FLAT HEAD MASONRY ANCHOR	3/16"	N/A	90H390000
WOOD STUD/GYPSUM WALL	#14 X 3" S/S PHILLIPS FLAT HEAD WOOD SCREW	7/32"	N/A	90H538004

P-RAWN / GN / VN HANDRAIL

LAYOUT VIEW

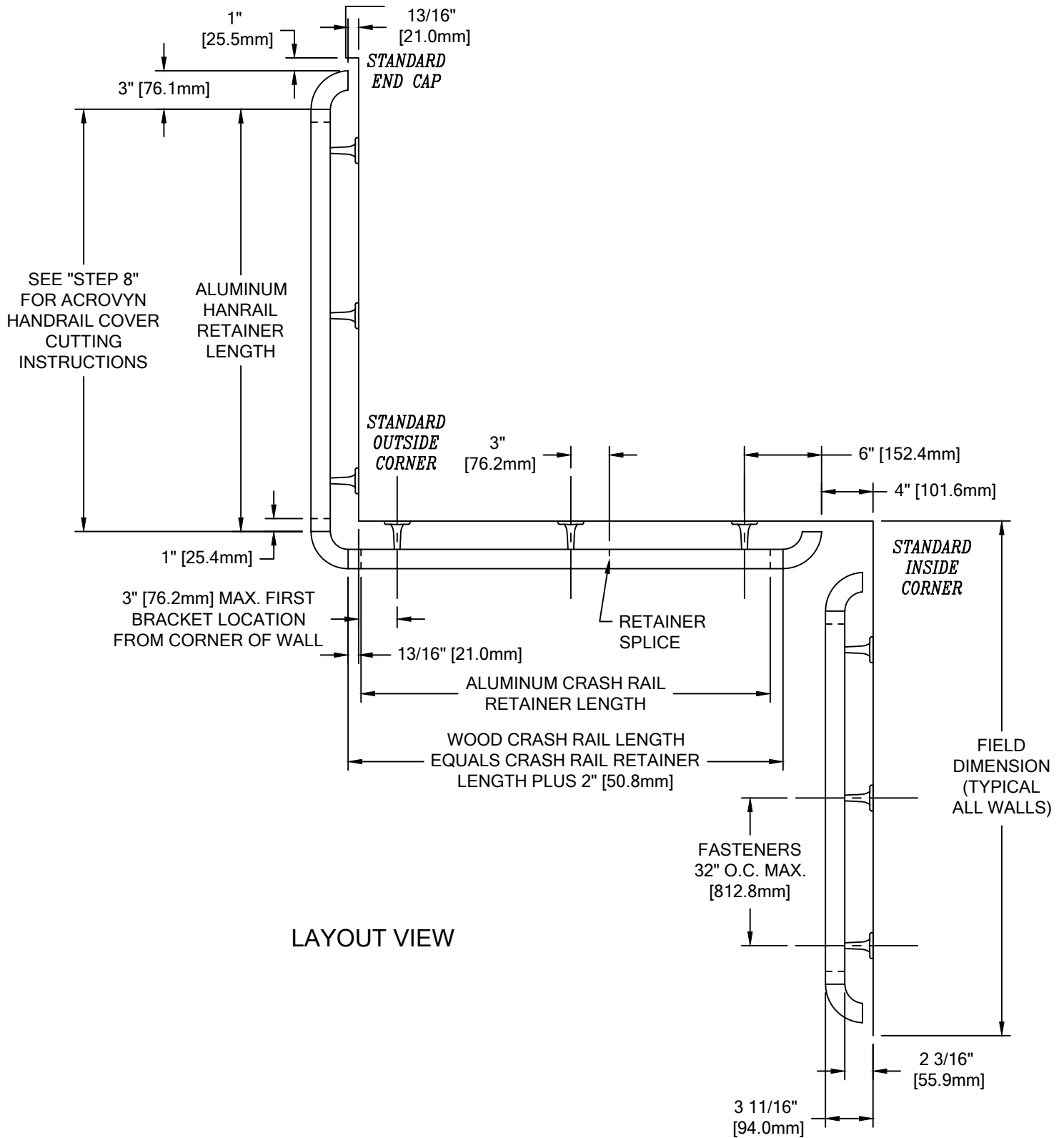

LAYOUT VIEW

**P-RAWN / GN / VN HANDRAIL
WITH INTERNATIONAL OFFSET**

TYPICAL ASSEMBLY

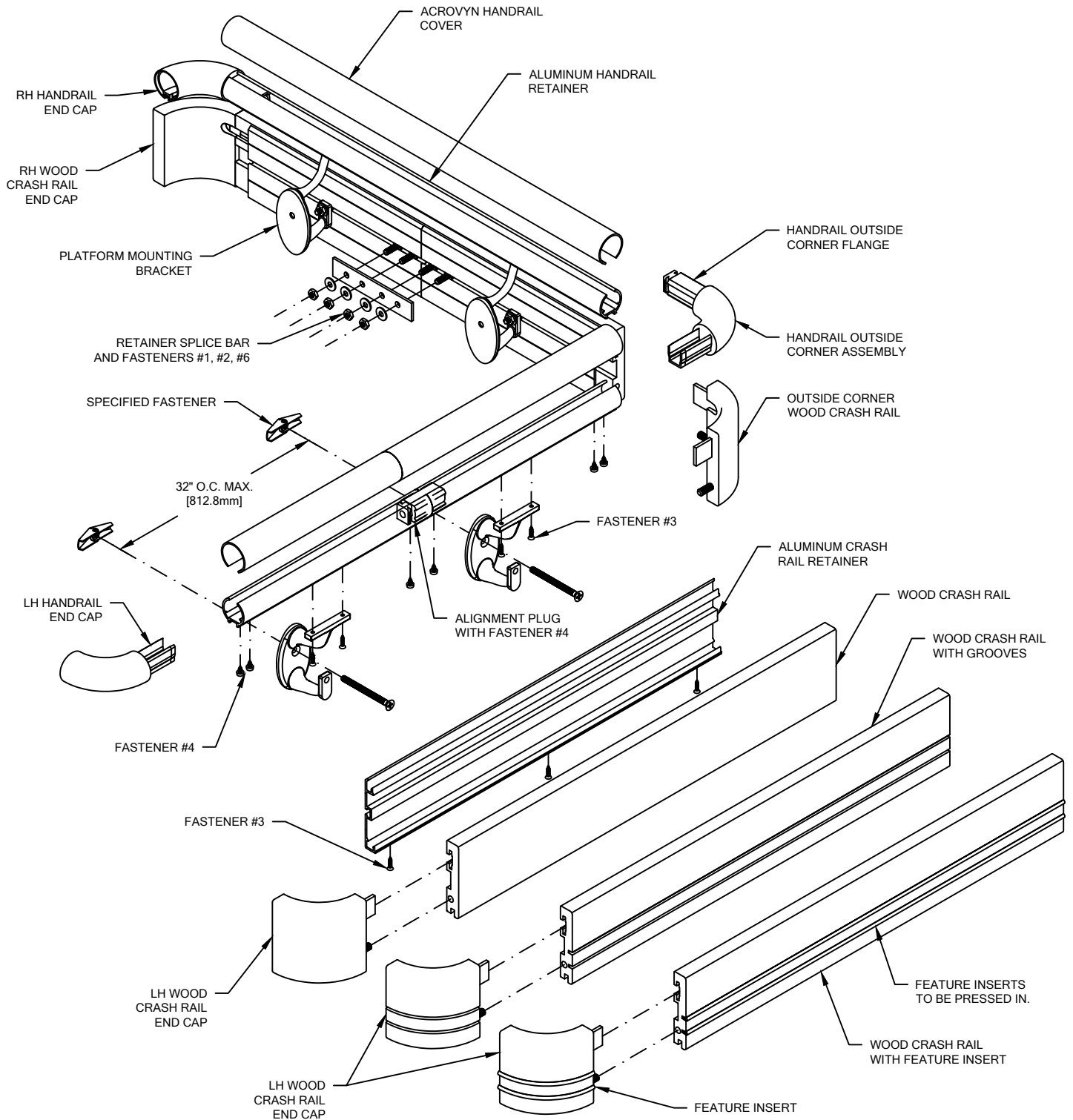

**P-RAWN / GN / VN HANDRAIL
WITH INTERNATIONAL OFFSET**

TYPICAL HANDRAIL ASSEMBLY

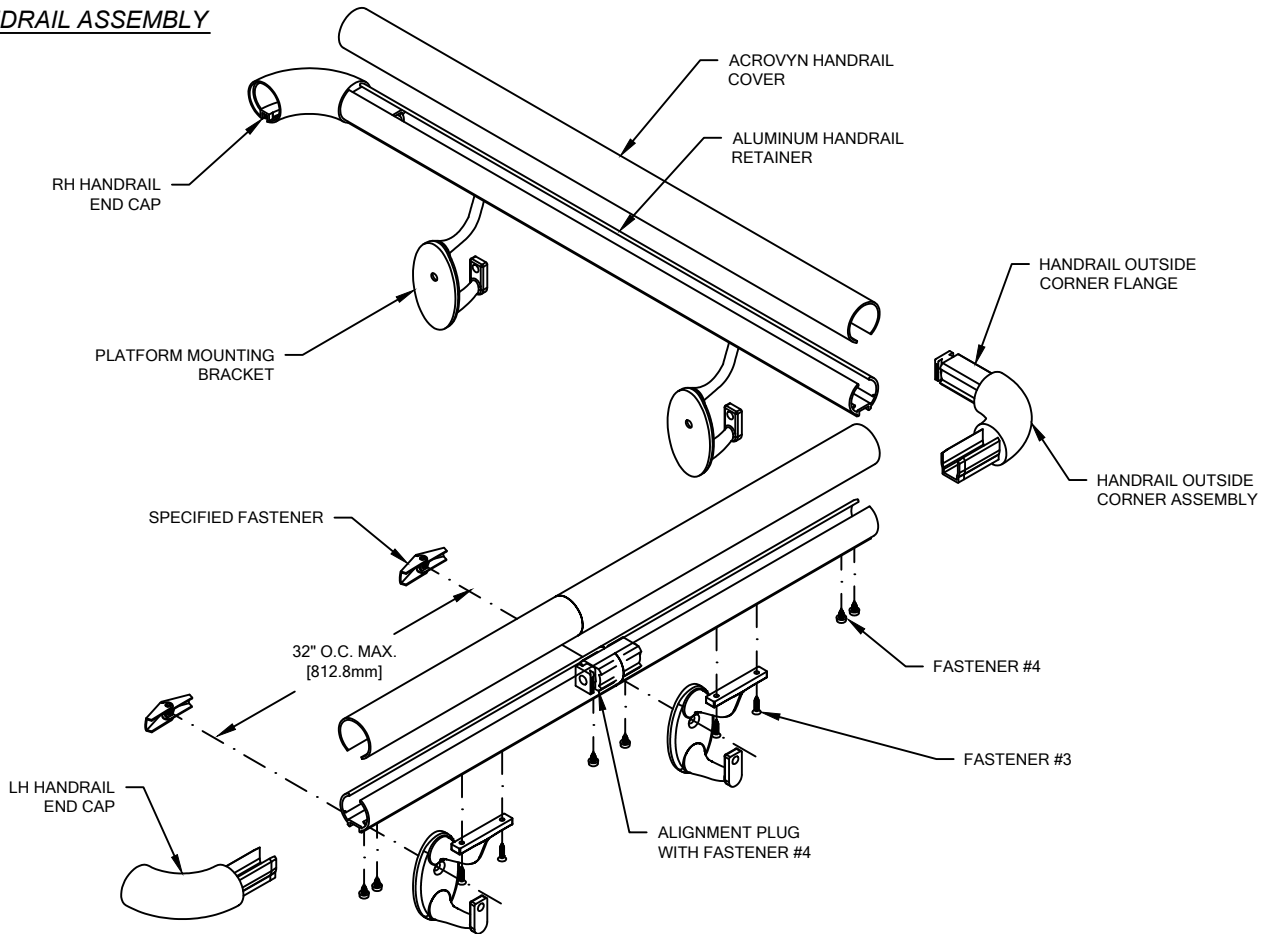

1. USING "LOCAL CODE" REQUIREMENTS, ESTABLISH HANDRAIL HEIGHT ABOVE FINISH FLOOR. DEDUCT 3 3/4" [95.3mm] AND SNAP A CHALK LINE AT THAT HEIGHT. THIS MARKS THE LOCATION OF THE HOLE FOR THE MOUNTING BRACKET FASTENERS.
2. DRILL CLEARANCE HOLES IN WALL SURFACE FOR MOUNTING HARDWARE. REFERENCE CHART ON PAGE 2 FOR CORRECT DRILL DIAMETERS.
3. INSTALL MOUNTING BRACKETS USING APPROPRIATE FASTENERS. USE A LEVEL TO ENSURE THAT THE BRACKETS ARE LEVEL.

NOTE: SEE LAYOUT VIEW TO AID IN MOUNTING BRACKET LOCATION.

4. CUT THE CONTINUOUS ALUMINUM RETAINER TO LENGTH USING THE REQUIRED DEDUCTIONS (REFERENCE LAYOUT VIEW).

NOTE: IT IS RECOMMENDED THAT THE ACROVYN COVER AND ALUMINUM RETAINER BE CUT WITH AN 80-100 TOOTH CARBIDE TIPPED SAW BLADE OR EQUIVALENT.

5. ATTACH END CAPS AND OUTSIDE CORNERS:
 - INSERT THE END CAP INTO THE RETAINER.
 - DRILL 1/8" DIAMETER PILOT HOLE THROUGH THE BOTTOM OF THE RETAINER AND END CAP, 5/8" [15.9mm] AND 1 1/4" [31.8mm] FROM THE END OF THE RETAINER.
 - REMOVE END CAP AND DRILL 11/64" CLEARANCE HOLE FOR #10 X 3/4" PHILLIPS PANHEAD TEK SCREW.
 - ATTACH END CAP TO RETAINER WITH THE ABOVE MENTIONED SCREWS, UP THROUGH THE BOTTOM OF THE RETAINER.

NOTE: TO AID IN LOCATING THE END CAPS CORRECTLY, CUT A 4" [101.6mm] SECTION OF COVER FROM SCRAP AND SNAP IT ON THE RETAINER. LOCATE THE CAP SO IT ALIGNS FLUSH WITH TOP AND BOTTOM OF THE COVER.

6. DRILL 1/16" PILOT HOLES INTO THE RETAINER FOR MOUNTING BRACKET ATTACHMENT. MOUNTING BRACKETS ARE TO BE LOCATED 3" [76.2mm] FROM EACH END OF THE RETAINER AND 32" [612.6mm] ON CENTER ALONG LENGTH, AS REQUIRED.
7. FASTEN THE ALUMINUM RETAINER TO THE WALL BRACKETS IN SUCCESSION BY INSERTING TWO #6 X 5/8" S/S PHILLIPS FLAT HEAD SHEET METAL SCREWS THROUGH THE UNDERSIDE OF BRACKET INTO THE RETAINER. **CAUTION:** OVER-TORQUEING MAY CAUSE THE FASTENERS TO STRIP.

**P-RAWN / GN / VN HANDRAIL
WITH INTERNATIONAL OFFSET**

8. CUT THE ACROVYN COVER TO THE PROPER LENGTH. THE COVER LENGTH IS DETERMINED BY MEASURING THE DISTANCE BETWEEN THE INSTALLED END CAPS AND/OR OUTSIDE CORNER ASSEMBLIES.

NOTE: IT IS RECOMMENDED THAT THE ACROVYN COVER BE CUT SLIGHTLY LONGER (1/32" [0.8mm] UP TO 5'-0" [1.5m], 1/16" [1.6mm] OVER 5'-0" [1.5m]) THAN THE MEASURED DISTANCE. THIS ADDITIONAL LENGTH WILL PROVIDE FOR A TIGHTER COVER-TO-END CAP FIT.

9. STARTING AT ONE END, SNAP THE ACROVYN COVER ONTO THE RETAINER ALONG THE LENGTH OF THE HANDRAIL.

NOTE: MANUFACTURER RECOMMENDS ALL PRINTED "PRODUCT IDENTIFICATION" ON THE REAR OF THE ACROVYN PROFILE SHALL BE ORIENTED IN THE SAME DIRECTION DURING INSTALLATION TO ENSURE PROPER ALIGNMENT AT SPLICE BUTT JOINTS.

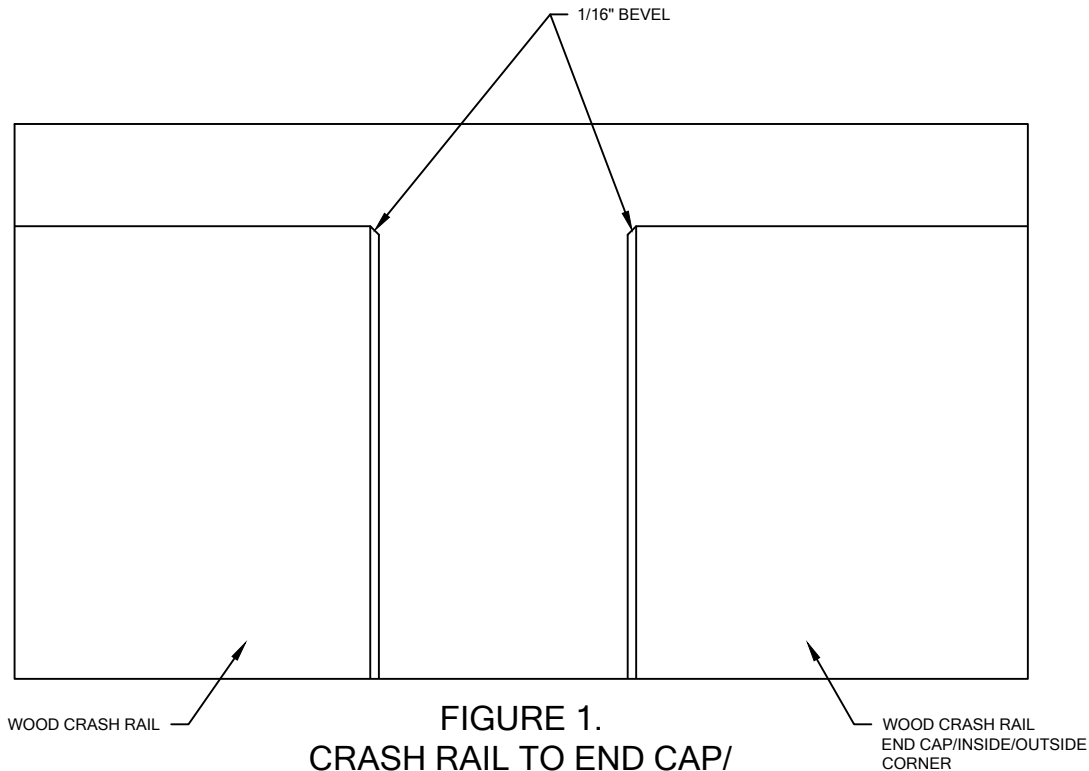

**FIGURE 1.
CRASH RAIL TO END CAP/
CRASH RAIL TO CRASH RAIL
BEVEL**

10. CUT THE CONTINUOUS ALUMINUM CRASH RAIL RETAINER TO LENGTH USING THE REQUIRED DEDUCTIONS (REFERENCE LAYOUT VIEW).

NOTE: IT IS RECOMMENDED THAT THE ALUMINUM CRASH RAIL RETAINER AND WOOD CRASH RAIL BE CUT WITH AN 80-100 TOOTH CARBIDE TIPPED SAW BLADE OR EQUIVALENT.

11. MARK FASTENER LOCATIONS ALONG V-GROOVE ON BOTTOM OF RETAINER. FASTENERS START 1" [25.4mm] FROM THE ENDS OF THE RETAINER AND ARE 24" [609.6mm] ON CENTER. USE THE SUPPLIED COUNTERSINKING DRILL FOR HOLES ALONG V-GROOVE WHERE WOOD CRASH RAIL FASTENS TO RETAINER. THIS WILL ALLOW SCREW HEADS TO BE FLUSH WITH RETAINER WHEN ASSEMBLED.

12. CUT THE WOOD CRASH RAIL TO LENGTH USING THE REQUIRED DEDUCTIONS (REFERENCE LAYOUT VIEW). ALL ENDS ARE TO BE CUT SQUARE. BEVEL THE CUT EDGES ON CRASH RAIL END SLIGHTLY WITH 150 GRIT SANDPAPER TO MATCH BEVEL ON WOOD END CAPS (SEE FIGURE ABOVE). TOUCH UP SANDED EDGES WITH SUPPLIED STAIN MARKER.

**P-RAWN / GN / VN HANDRAIL
WITH INTERNATIONAL OFFSET**

TYPICAL CRASH RAIL ASSEMBLY

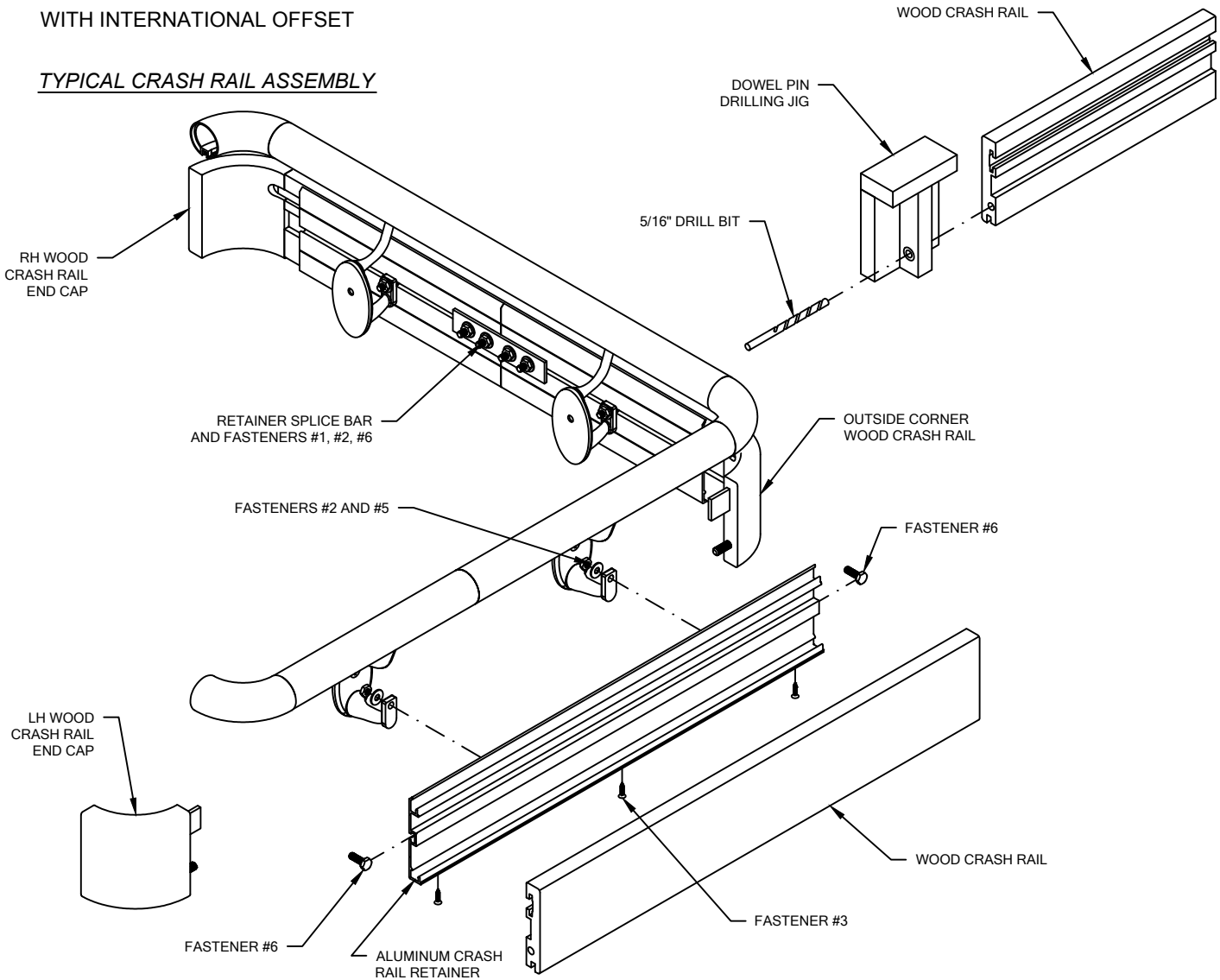

13. ATTACH CRASH RAIL END CAPS AND OUTSIDE CORNERS:

- SLIDE 1/4-20 X 3/4" HEX HEAD BOLTS IN RECEIVER SLOT OF THE CRASH RAIL RETAINER FOR ALL WALL BRACKETS.
- AN END CAP ALIGNMENT HOLE MUST BE DRILLED AT EACH END USING THE SUPPLIED JIG (SEE ILLUSTRATION). DO NOT DRILL THIS HOLE WITHOUT THE JIG. USE DRILL JIG TO PRE-DRILL CLEARANCE HOLES 7/8" DEEP INTO CRASH RAIL USING A 5/16" DRILL BIT.
- CONTINUALLY CLEAN OUT WOOD CHIPS AS THE PILOT HOLE IS BEING DRILLED.
- APPLY WOOD GLUE INTO THE HOLES AND CUT SURFACE OF CRASH RAIL (TITEBOND IS RECOMMENDED).
- ATTACH WOOD END CAPS TO CRASH RAIL BY SLIDING THE END CAP TAB AND DOWEL INTO MATING CRASH RAIL CLEARANCE HOLES. WIPE OFF ANY EXCESS GLUE.
- CHECK SEAM FOR TIGHT FIT BETWEEN CRASH RAIL AND END CAP.

14. ATTACH WOOD CRASH RAIL ONTO ALUMINUM CRASH RAIL RETAINER. USING THE PREVIOUSLY DRILLED COUNTERSUNK HOLE IN THE RETAINER AS A GUIDE, DRILL 3/32" DIAMETER PILOT HOLE 3/8" DEEP IN THE BOTTOM WOOD CRASH RAIL TO ACCEPT THE #6 X 5/8" SCREWS.

15. ATTACH THE ASSEMBLED CRASH RAIL TO THE WALL BRACKETS BY ALIGNING THE HEX HEAD BOLTS WITH THE MOUNTING BRACKETS AND INSERTING THE HEX HEAD BOLT INTO THE MOUNTING BRACKET HOLE. PLACE A 1/4" FLAT WASHER AND 1/4-20 HEX NUT ONTO THE HEX HEAD BOLT AND TIGHTEN AS REQUIRED.

3/31/17