

## P-RASN HANDRAIL

### PLEASE READ

PLEASE READ THESE INSTRUCTIONS THOROUGHLY PRIOR TO BEGINNING THE P-RASN HANDRAIL INSTALLATION!

THIS INSTRUCTION SHEET IS INTENDED TO PROVIDE A SPECIFIC GUIDE TO FOLLOW FOR THE INSTALLATION OF THIS P-RASN HANDRAIL. CONTAINED WITHIN IS THE TECHNICAL INFORMATION AND INSTALLATION TECHNIQUES REQUIRED TO COMPLETE AN EFFICIENT, NEAT AND LONG-LASTING INSTALLATION.

INSPECT ALL MATERIALS FOR DAMAGE OR MISSING PARTS. IF YOU DISCOVER DAMAGED OR MISSING MATERIALS, IN THE USA PLEASE NOTIFY THE FACTORY AT (800) 233-8493, AND IN CANADA (888) 895-8955 FOR CUSTOMER SERVICE.

P-RASN HANDRAIL MUST BE INSTALLED IN ACCORDANCE WITH THESE INSTRUCTIONS! FAILURE TO FOLLOW THESE INSTRUCTIONS MAY VOID ANY PRODUCT WARRANTIES AND RESULT IN AN UNSUCCESSFUL INSTALLATION. FOR SPECIFIC QUESTIONS REGARDING THE INSTALLATION OF THIS P-RASN HANDRAIL PLEASE CALL THE FACTORY IN THE USA AT (800) 233-8493 OR EMAIL [IWPTECHSUPPORT@C-SGROUP.COM](mailto:IWPTECHSUPPORT@C-SGROUP.COM). IN CANADA CALL (888) 895-8955.

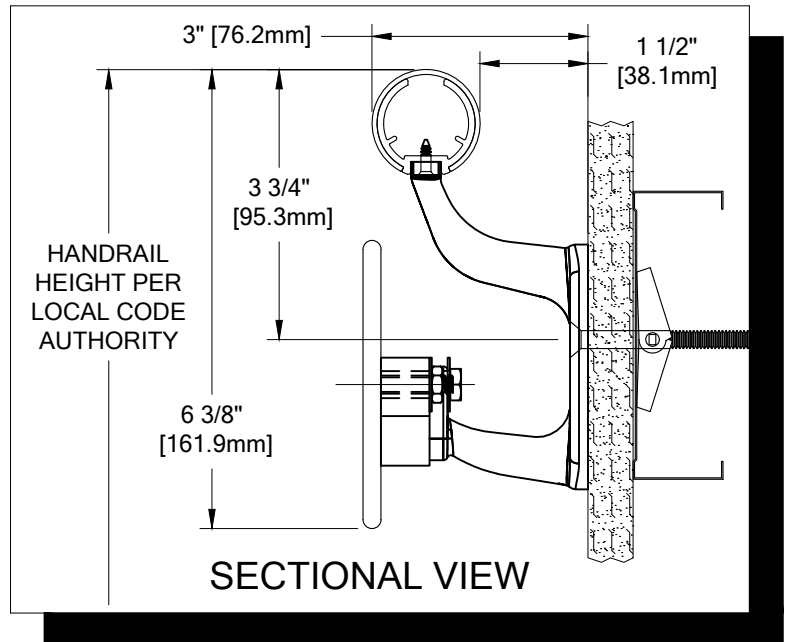

### IMPORTANT NOTES

1. THIS HANDRAIL HAS BEEN MANUFACTURED TO CUSTOMER SPECIFIED DIMENSIONS AND CAN NOT BE CUT OR MODIFIED ON SITE. TO DO SO COULD VOID THE WARRANTY.
2. ALL DIMENSIONS ARE TYPICAL.
3. FOR DRYWALL/PLASTER WALL CONSTRUCTION, IT IS RECOMMENDED FOR FASTENERS TO BE ENGAGED INTO METAL/WOOD STUDS TO MAINTAIN MAXIMUM PULLOUT STRENGTH. IF DURING INSTALLATION YOU ENCOUNTER SPECIAL WALL CONDITIONS THAT DO NOT ALLOW FOR DIRECT ATTACHMENT TO THE STUDS PLEASE CONSULT THE LOCAL AUTHORITY HAVING JURISDICTION.
4. INSTALL OUTSIDE CORNERS FIRST.
5. INSTALL LONGEST RUN OF HANDRAIL FIRST.
6. ALUMINUM RETAINER SPLICE SHOULD NOT EXCEED 3" [76.2mm] DISTANCE FROM A BRACKET.
7. THE DISTANCE BETWEEN AN ACROVYN SPLICE JOINT AND AN ALUMINUM RETAINER SPLICE JOINT SHOULD NOT BE LESS THAN 12" [304.8mm].
8. MATERIAL MUST REACH 65°F MIN. TO 75° MAX. 24 HOURS PRIOR TO INSTALLATION. THIS IS ESSENTIAL TO MINIMIZE EXPANSION AND CONTRACTION.
9. MAY REQUIRE USE OF FIRE PUTTY WHEN INSTALLED ON FIRE WALL WITH TOGGLE BOLTS. REFERENCE INSTRUCTIONS 24FIREPUTTY FOR FIRE PUTTY INSTALLATION.
10. THIS HANDRAIL REQUIRES A MINIMUM OF 2 MOUNTING BRACKETS PER UNIT. THE MINIMUM END CAP-TO-END CAP HANDRAIL LENGTH IS 14" [355.6mm].
11. FOR MORE INFORMATION ON P-RASN HANDRAIL SEE OUR WEBSITE AT [www.c-sgroup.com](http://www.c-sgroup.com).

**P-RASN HANDRAIL**

COMPONENTS & WALL FASTENERS



ACROVYN HANDRAIL COVER  
(24U032xxx)  
ACROVYN WOODGRAINS  
AND BRUSHED METALS COVER  
(24U610xxx)



ALUMINUM HANDRAIL  
RETAINER  
(24A095000)

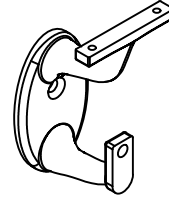

STAINLESS STEEL  
MOUNTING BRACKET  
(24S160000)

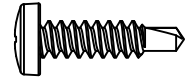

**FASTENER #1**  
#10 X 3/4" PHILLIPS  
PANHEAD TEK SCREW  
(90H739002)



**FASTENER #2**  
#6 X 5/8" S/S PHILLIPS  
FLAT HEAD SMS  
(90H231004)

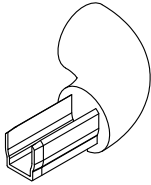

HANDRAIL END CAP  
(24I082xxx, LH)  
(24I083xxx, RH SHOWN)  
ACROVYN WOODGRAINS  
AND BRUSHED METALS END CAP  
(24I610xxx, LH)  
(24I634xxx, RH SHOWN)

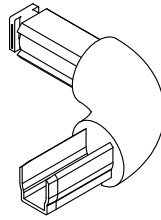

HANDRAIL OUTSIDE  
CORNER ASSEMBLY

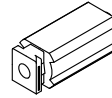

ALIGNMENT PLUG  
(24I051000)

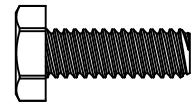

**FASTENER #3**  
1/4"-20 X 3/4"  
HEX HEAD MACHINE SCREW  
(90H008002)



STAINLESS STEEL  
CRASH RAIL

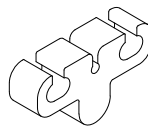

BRACKET ADAPTER PLATE  
(24F230003)

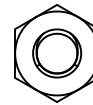

**FASTENER #5**  
1/4"-20 HEX NUT  
(90H010001)

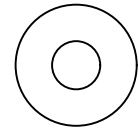

**FASTENER #4**  
1/4" FLAT WASHER  
(90H007003)

WALL CONDITION	SPECIFIED FASTENER	DRILL DIAMETERS		CS PART NUMBER
		WALL	RETAINER	
STEEL STUD/GYPSUM WALL	1/4-20 X 3" S/S FLAT HEAD BOLT WITH TOGGLE	3/4"	N/A	90H184002
CONCRETE/CONCRETE BLOCK	1/4" X 1 3/4" S/S FLAT HEAD MASONRY ANCHOR	3/16"	N/A	90H390000
WOOD STUD/GYPSUM WALL	#14 X 3" S/S PHILLIPS FLAT HEAD WOOD SCREW	7/32"	N/A	90H538004
20 GA. STEEL STUD/GYPSUM WALL (OSHDP)	1/4-20 X 3" S/S FLAT HEAD BOLT 1/4" TOGGLER WING 3M MOLDABLE FIRE PUTTY	1/2"	N/A	90H063002 90H062004 90M012000
16 GA. MIN. STEEL STUD AND 16 GA. MIN. STEEL STRAPPING / GYPSUM WALL CONSTRUCTION REQUIRED (TEK SCREWS)	#14 X 3" PHILLIPS FLAT HEAD SELF DRILLING S/S TEK SCREW	N/A	N/A	90H230003

P-RASN HANDRAIL

LAYOUT VIEW

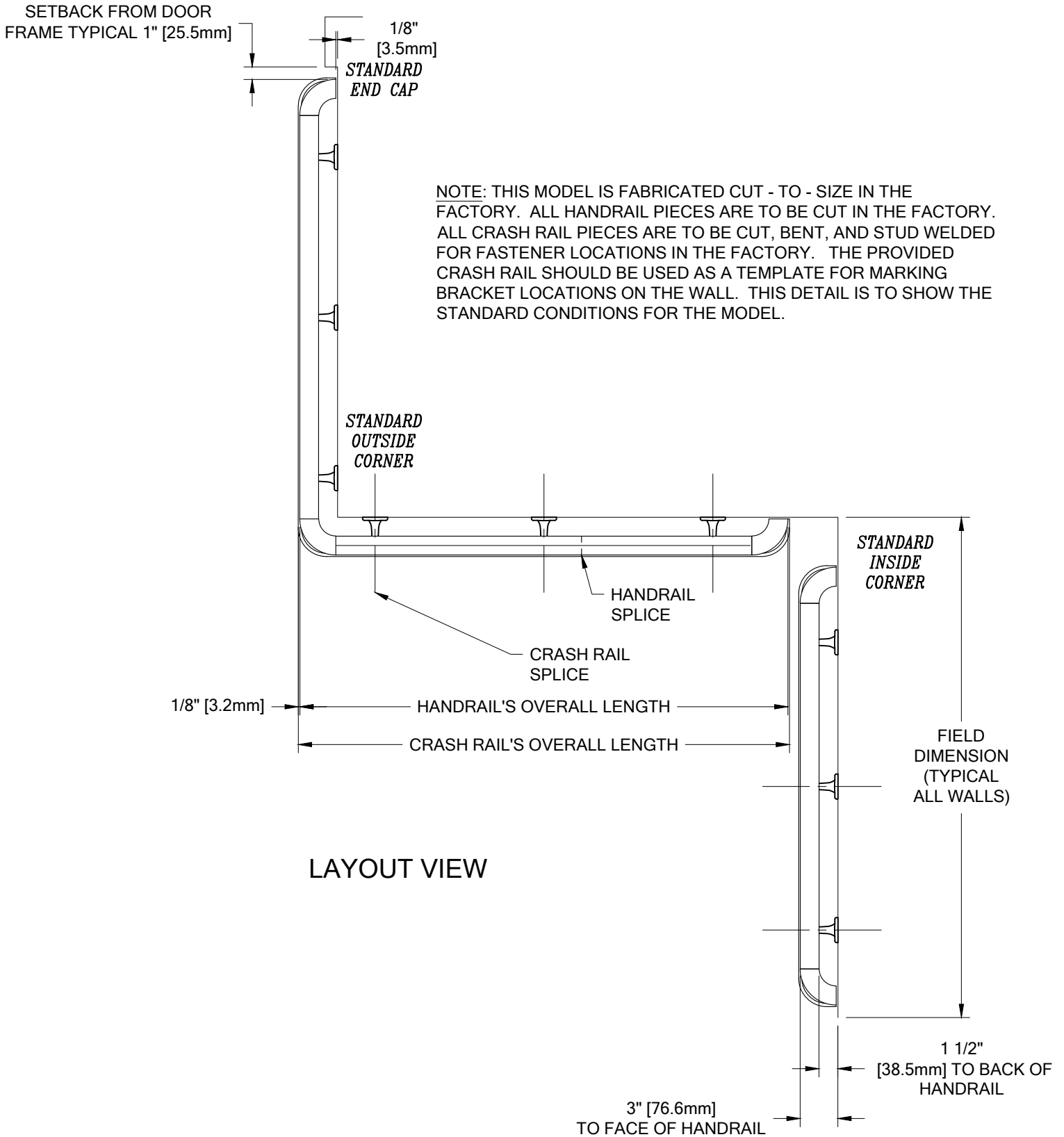

P-RASN HANDRAIL

TYPICAL ASSEMBLY

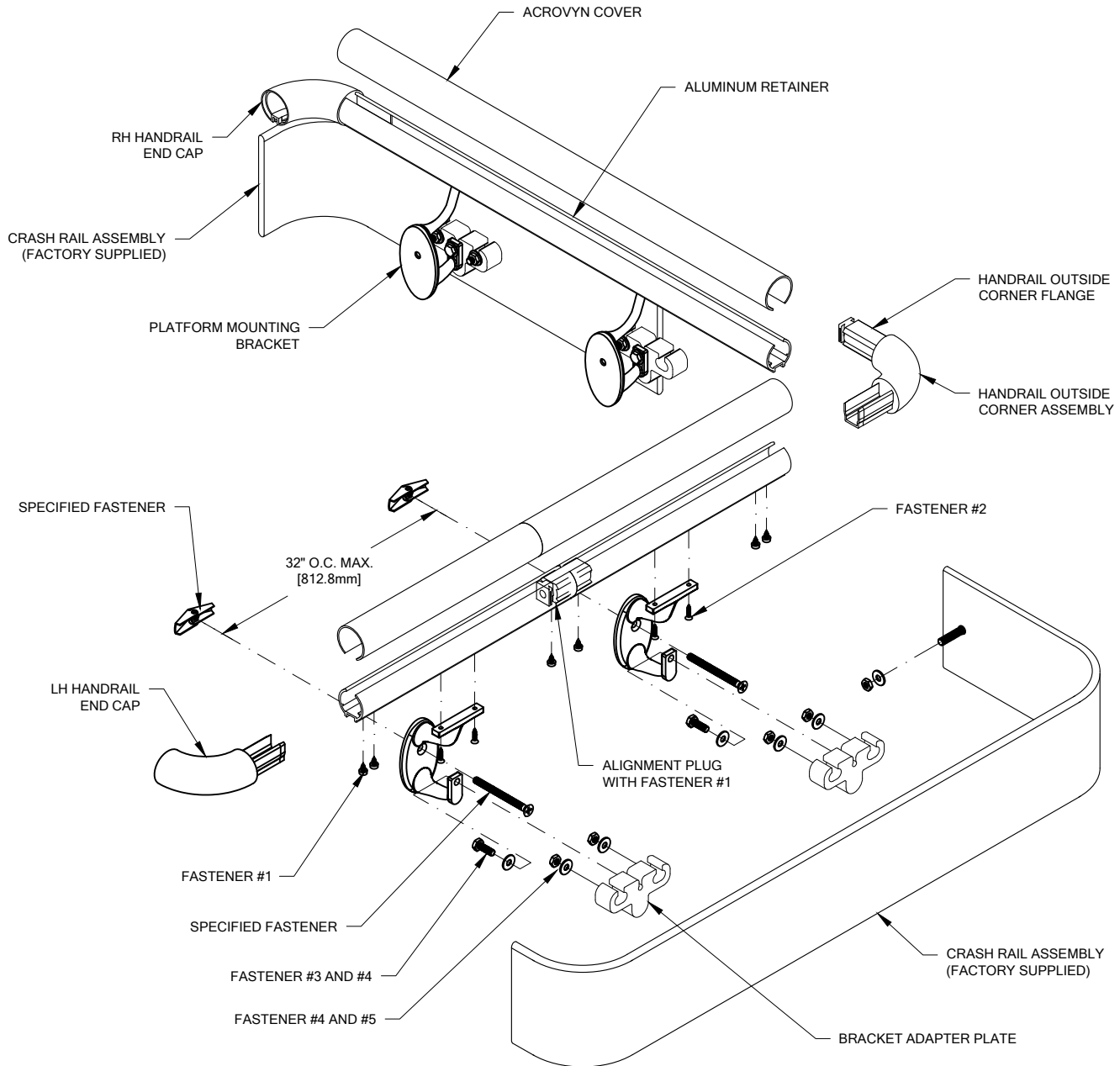

P-RASN HANDRAIL

TYPICAL HANDRAIL ASSEMBLY

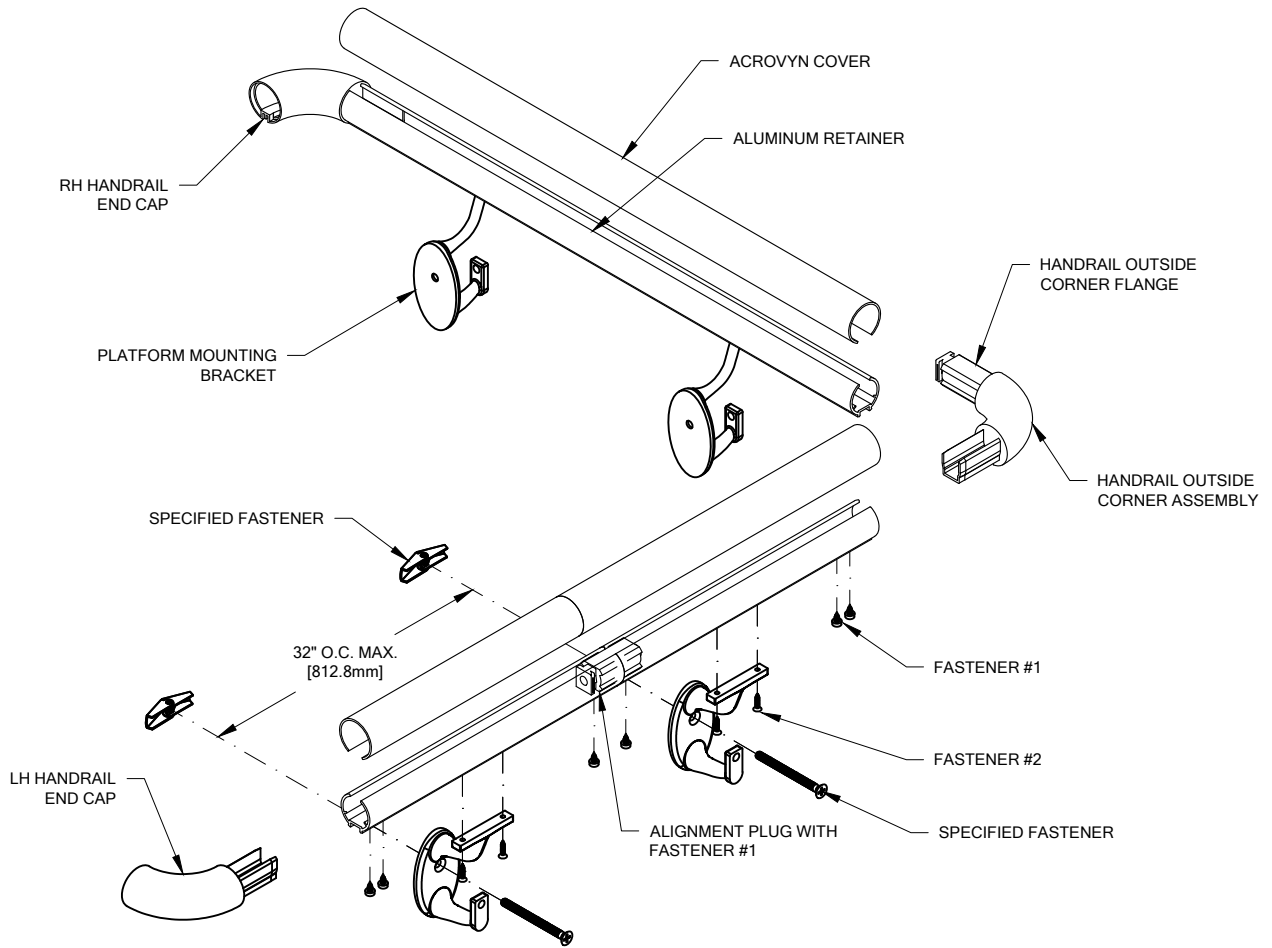

**NOTE:** THIS MATERIAL HAS BEEN MANUFACTURED TO CUSTOMER SPECIFIED DIMENSIONS AND CAN NOT BE CUT OR MODIFIED ON SITE. TO DO SO COULD VOID THE WARRANTY.

1. USING "LOCAL CODE" REQUIREMENTS, ESTABLISH HANDRAIL HEIGHT ABOVE FINISH FLOOR. DEDUCT 3 3/4" [95.3mm] AND SNAP A CHALK LINE AT THAT HEIGHT. THIS MARKS THE LOCATION OF THE HOLE FOR THE MOUNTING BRACKET FASTENERS.
2. DRILL CLEARANCE HOLES IN WALL SURFACE FOR MOUNTING HARDWARE. REFERENCE CHART ON PAGE 2 FOR CORRECT DRILL DIAMETERS. USE CRASH RAIL WITH ATTACHED BRACKETS AS A TEMPLATE TO MARK BRACKET LOCATIONS ON THE WALL, REFERENCE STEP #8.
3. INSTALL MOUNTING BRACKETS USING APPROPRIATE FASTENERS. DO NOT OVER TORQUE THE FASTENERS. USE A LEVEL TO ENSURE THAT THE BRACKETS ARE LEVEL. WARNING: MOUNTING BRACKET LOCATIONS MUST BE IDENTICAL TO THE FACTORY INSTALLED STUDS ON THE BACKSIDE OF THE CRASH RAIL.
4. ATTACH END CAPS AND OUTSIDE CORNERS:
  - INSERT THE END CAP INTO THE RETAINER.
  - DRILL 1/8" DIAMETER PILOT HOLES THROUGH THE BOTTOM OF THE RETAINER AND END CAP, 5/8" [15.9mm] AND 1 1/4" [31.8mm] FROM THE END OF THE RETAINER AS SHOWN.
  - REMOVE END CAP AND DRILL 11/64" CLEARANCE HOLES FOR #10 X 3/4" PHILLIPS PANHEAD TEK SCREWS.
  - ATTACH END CAP TO RETAINER WITH THE ABOVE MENTIONED SCREWS, UP THROUGH THE BOTTOM OF THE RETAINER.
5. DRILL 1/16" PILOT HOLES INTO THE RETAINER FOR MOUNTING BRACKET ATTACHMENT. MOUNTING BRACKETS ARE TO BE LOCATED 3" [76.2mm] FROM EACH END OF THE RETAINER AND 32" [812.6mm] ON CENTER ALONG LENGTH, AS REQUIRED.
6. FASTEN THE ALUMINUM RETAINER TO THE WALL BRACKETS IN SUCCESSION BY INSERTING TWO #6 X 5/8" S/S PHILLIPS FLAT HEAD SHEET METAL SCREWS THROUGH THE UNDERSIDE OF BRACKET INTO THE RETAINER. CAUTION: OVER-TORQUEING MAY CAUSE THE FASTENERS TO STRIP.
7. STARTING AT ONE END, SNAP THE ACROVYN COVER ONTO THE RETAINER ALONG THE LENGTH OF THE HANDRAIL.

**NOTE:** MANUFACTURER RECOMMENDS ALL PRINTED "PRODUCT IDENTIFICATION" ON THE REAR OF THE ACROVYN PROFILE SHALL BE ORIENTED IN THE SAME DIRECTION DURING INSTALLATION TO ENSURE PROPER ALIGNMENT AT SPLICE BUTT JOINTS.

P-RASN HANDRAIL

TYPICAL CRASH RAIL ASSEMBLY

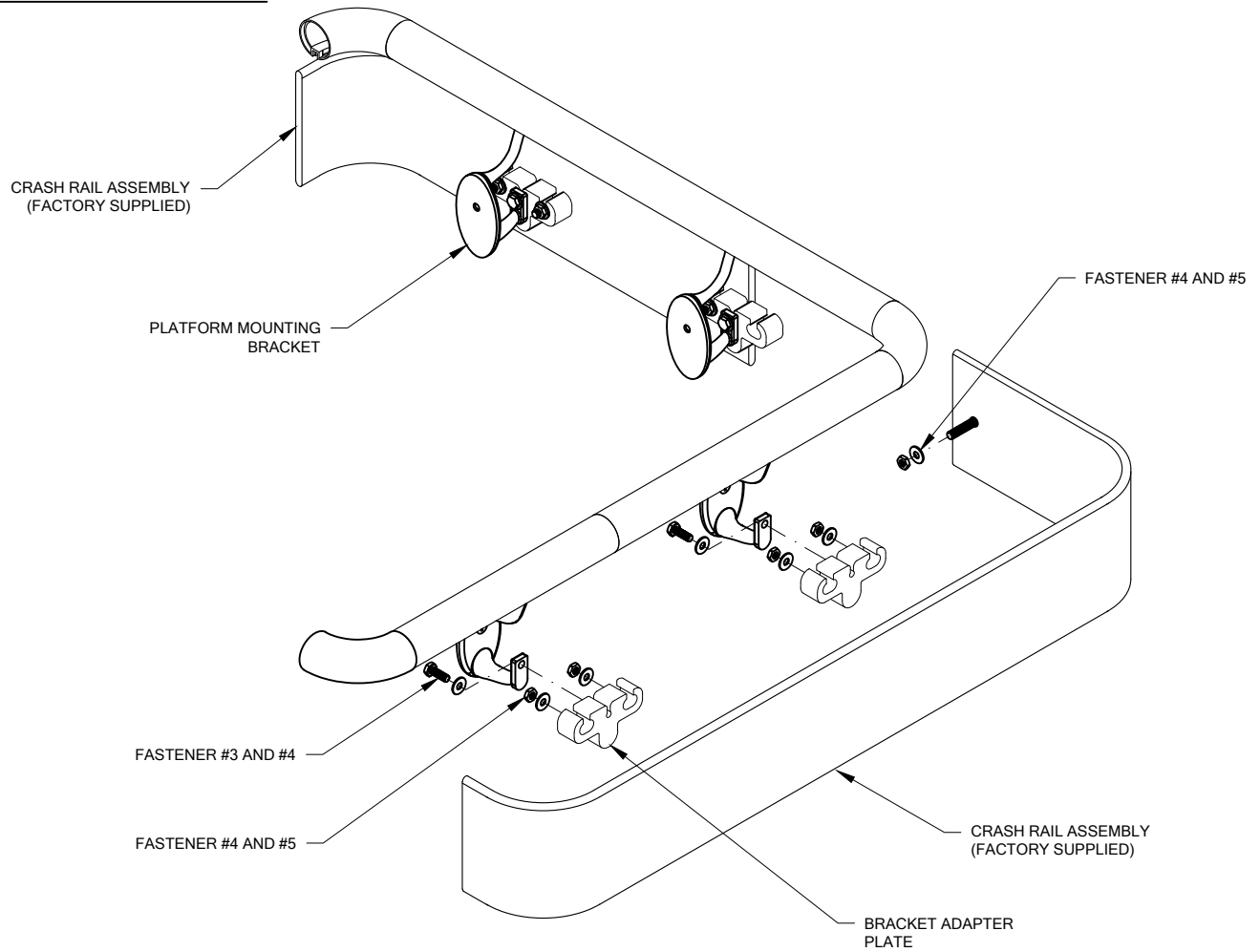

8. ATTACH CRASH RAIL TO THE WALL MOUNTING BRACKETS:
- DISTRIBUTE MATERIAL. MATCH THE NUMBER ON THE BACK OF THE RAIL TO THE MARK NUMBER ON THE DRAWING. SOME LARGE RUNS REQUIRE MORE THAN ONE PIECE OF CRASH RAIL. THESE ARE NOTED WITH A MARK NUMBER AND A LETTER, I.E., 2001A, 2001B.
  - LOCATE A BRACKET ADAPTER PLATE ON EACH SET OF THREADED STUDS ON THE BACKSIDE OF THE CRASH RAIL.
  - SECURE THE BRACKET ADAPTER PLATE BY INSTALLING A 1/4" WASHER AND 1/4-20 NUT ONTO EACH THREADED STUD.
  - ALIGN EACH MOUNTING BRACKET WITH THE BRACKET ADAPTER PLATE'S THREADED HOLE.
  - INSERT 1/4-20 HEX HEAD BOLT AND 1/4" WASHER THROUGH THE MOUNTING BRACKET AND INTO THE MOUNTING BRACKET'S THREADED HOLE. THE BRACKET ADAPTER PLATE IS SLOTTED TO ACCOMMODATE ANY SLIGHT MISALIGNMENT.
  - FASTENERS MUST BE TORQUED TO 150 IN/LBS.

09/10/2024