

POWDER COATS:
 *TOP RAIL: _____
 BOTTOM RAIL: _____
 *BRACKETS: _____
 PLEASE ADVISE BOTTOM RAIL POWDER COAT FINISH. REFER TO CS CATALOG FOR OPTIONS.
 *TOP RAIL/CAPS/CORNERS/BRACKETS ARE AVAILABLE WITH AN OPTIONAL POWDER COAT FINISH. PLEASE ADVISE POWDER COAT FINISH IF REQUIRED.

| TOTAL L/F REQ'D | END CAPS | O.S. REQ'D |
|-----------------|----------|------------|
| | | |
| | | |
| | | |

NOTE: STAINLESS STEEL CORNERS OTHER THAN 90° ARE UNAVAILABLE FOR THIS MODEL. THIS MODEL IS FABRICATED CUT-TO-SIZE, THEREFORE FIELD VERIFIED DIMENSIONS ARE REQUIRED.

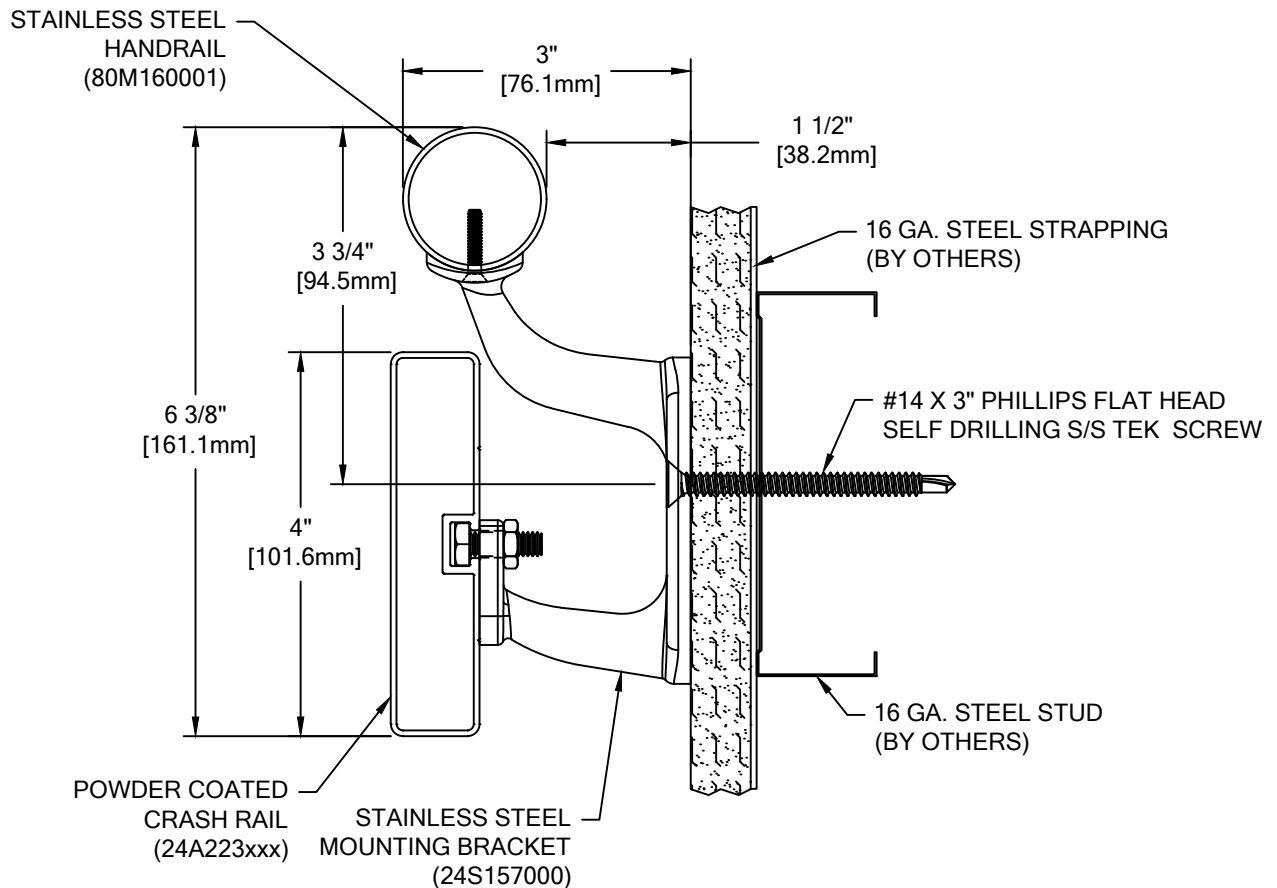

P-RSM

| WALL CONDITION | SPECIFIED FASTENER | DRILL DIAMETERS | | CS PART NUMBER |
|---|---|-----------------|----------|----------------|
| | | WALL | RETAINER | |
| STEEL STUD/GYPSUM WALL | 1/4-20 X 3" S/S FLAT HEAD BOLT WITH TOGGLE | 3/4" | N/A | 90H184002 |
| CONCRETE/CONC. BLOCK | 1/4" X 1 3/4" S/S FLAT HEAD MASONRY ANCHOR | 3/16" | N/A | 90H390000 |
| WOOD STUD/GYPSUM WALL | #14 X 3" S/S PHILLIPS FLAT HEAD WOOD SCREW | 7/32" | N/A | 90H538004 |
| 16 GA. MIN STEEL STUD AND 16 GA. MIN STEEL STRAPPING / GYPSUM WALL (CONSTRUCTION REQUIRED) (TEK SCREWS) | #14 X 3" PHILLIPS FLAT HEAD SELF DRILLING S/S TEK SCREW | N/A | 9/32" | 90H230003 |

| | | |
|---|------------------|------------------|
|  Hughesville, PA 800.233.8493 570.546.5941 Mississauga, ON 888.895.8955 905.274.3611 www.c-sgroup.com © Copyright 2019 Construction Specialties, Inc. | PROJECT: | REVISION: |
| | JOB NO.: | F&F: |
| | CUSTOMER: | |
| | REP: | DATE: |
| | DRAWN BY: | SHEET NO: |