

HRB-4CCMHLN HANDRAIL

HIGH LOAD HANDRAIL

PLEASE READ

PLEASE READ THESE INSTRUCTIONS THOROUGHLY PRIOR TO BEGINNING THE HRB-4CCMHLN HANDRAIL INSTALLATION!

THIS INSTRUCTION SHEET IS INTENDED TO PROVIDE A SPECIFIC GUIDE TO FOLLOW FOR THE INSTALLATION OF THIS HRB-4CCMHLN HANDRAIL. CONTAINED WITHIN IS THE TECHNICAL INFORMATION AND INSTALLATION TECHNIQUES REQUIRED TO COMPLETE AN EFFICIENT, NEAT AND LONG-LASTING INSTALLATION.

INSPECT ALL MATERIALS FOR DAMAGE OR MISSING PARTS. IF YOU DISCOVER DAMAGED OR MISSING MATERIALS, IN THE USA PLEASE NOTIFY THE FACTORY AT (800) 233-8493, AND IN CANADA (888) 895-8955 FOR CUSTOMER SERVICE.

HRB-4CCMHLN HANDRAIL MUST BE INSTALLED IN ACCORDANCE WITH THESE INSTRUCTIONS! FAILURE TO FOLLOW THESE INSTRUCTIONS MAY VOID ANY PRODUCT WARRANTIES AND RESULT IN AN UNSUCCESSFUL INSTALLATION. FOR SPECIFIC QUESTIONS REGARDING THE INSTALLATION OF THIS HRB-4CCMHLN HANDRAIL PLEASE CALL THE FACTORY IN THE USA AT (800) 233-8493 OR EMAIL IWPTECHSUPPORT@C-SGROUP.COM. IN CANADA CALL (888) 895-8955.

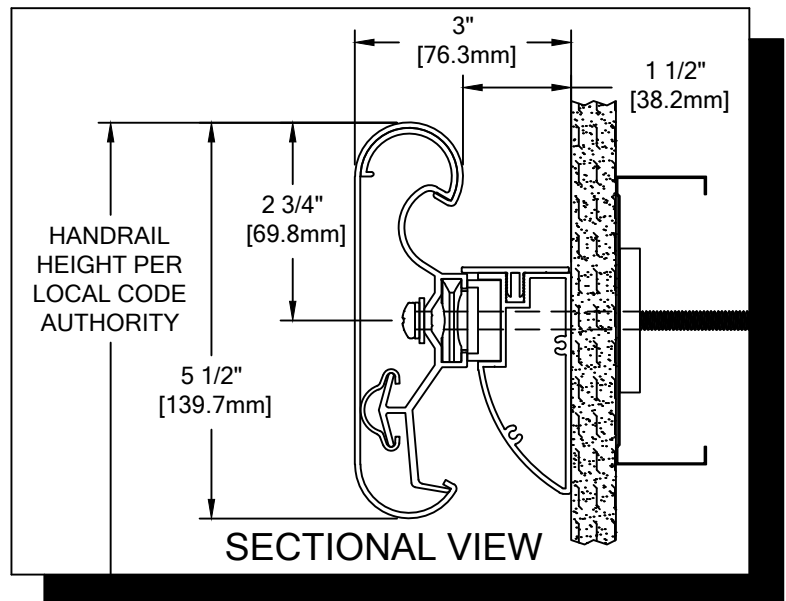

IMPORTANT NOTES

1. ALL LINEAL MATERIAL TO BE SUPPLIED IN STOCK LENGTHS. ALUMINUM AND ACROVYN IN LENGTHS UP TO 20'-0". THIS MATERIAL IS TO BE FIELD CUT USING QUALITY EQUIPMENT TO INSURE THAT ALL CUTS ARE SQUARE. WHEN CUTTING MATERIAL SECTIONS, C/S RECOMMENDS USING AN 80-100 TOOTH CARBIDE TIPPED SAW BLADE OR EQUIVALENT, TO MINIMIZE CHIPPING AND MAINTAIN JOINT ALIGNMENT.
2. ALL DIMENSIONS ARE TYPICAL.
3. FOR DRYWALL/PLASTER WALL CONSTRUCTION, IT IS RECOMMENDED FOR FASTENERS TO BE ENGAGED INTO METAL/WOOD STUDS TO MAINTAIN MAXIMUM PULLOUT STRENGTH.
4. INSTALL OUTSIDE CORNERS FIRST.
5. INSTALL LONGEST RUN OF HANDRAIL FIRST.
6. ALUMINUM RETAINER SPLICE SHOULD NOT EXCEED 4" [101.6mm] DISTANCE FROM A BRACKET.
7. THE DISTANCE BETWEEN AN ACROVYN SPLICE JOINT AND AN ALUMINUM RETAINER SPLICE JOINT SHOULD BE STAGGERED 4" [101.6mm].
8. MATERIAL MUST REACH 65°F MIN. TO 75°F MAX. 24 HOURS PRIOR TO INSTALLATION. THIS IS ESSENTIAL TO MINIMIZE EXPANSION AND CONTRACTION OF MATERIAL.
9. MAY REQUIRE USE OF FIRE PUTTY WHEN INSTALLED ON FIRE WALL WITH TOGGLE BOLTS. REFERENCE INSTRUCTIONS 24FIREPUTTY FOR FIRE PUTTY INSTALLATION.
10. THIS HANDRAIL REQUIRES A MINIMUM OF 2 MOUNTING BRACKETS PER UNIT. THE MINIMUM END CAP-TO-END CAP HANDRAIL LENGTH IS 17" [431.8mm].
11. FOR HIGH LOAD HANDRAIL USE A MINIMUM 20 GA. STEEL STUD AND 20 GA. STEEL STRAPPING AND 5/8" GYPSUM WALL BOARD.
12. FOR MORE INFORMATION ON HRB-4CCMHLN HANDRAIL SEE OUR WEBSITE AT www.c-sgroup.com.

HRB-4CCMHLN HANDRAIL

COMPONENTS & WALL FASTENERS



ACROVYN COVER
(24U008xxx)
ACROVYN CHAMELEON
(24U604xxx)

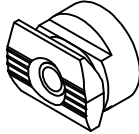

QUICK LOCK
(24I821000)



ALUMINUM RETAINER
(24A306000)

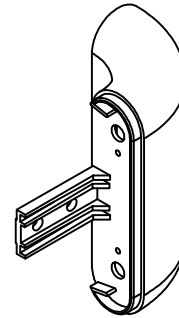

HANDRAIL END CAP
(24I115xxx)
CHAMELEON END CAP
(24I988xxx)

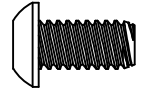

FASTENER #1
1/4-20 X 1/2" BUTTON
SOCKET HEAD CAP SCREW
(90H772002)

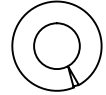

FASTENER #2
1/4" LOCK WASHER
(90H006003)



LIGATURE RESISTANT
MOUNTING BRACKET
(24A336000)



OPTIONAL REVEAL
(24I845xxx)
OPTIONAL S/S REVEAL
(24S096000)

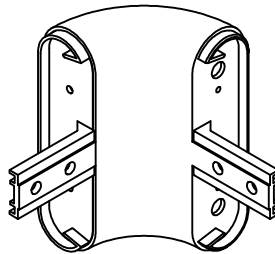

HANDRAIL CORNER ASSEMBLY
(OUTSIDE, 4COSxxx)
(INSIDE, 4CISxxx)



TOP PLATE
(24A337000)



RC-10 CUSHION
(24U952108)

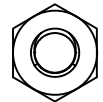

FASTENER #3
1/4-20 HEX NUT
(90H010001)

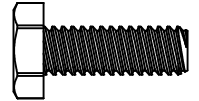

FASTENER #4
1/4-20 X 3/4"
HEX HEAD MACHINE SCREW
(90H008002)

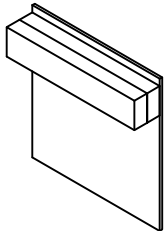

ACROVYN LINE-UP SPLICE
(24F041002)



CLOSING PLATE
(24F258000)

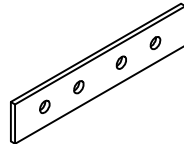

RETAINER SPLICE BAR
(24I976000)



FASTENER #5
#6 X 1/2" 18-8 S/S
PIN-IN-TORX TAMPER-RESISTANT
SHEET METAL SCREW
(90H881002)

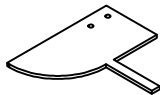

END PLATE
(24F259000)

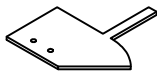

OUTSIDE CORNER PLATE
(24F262000)

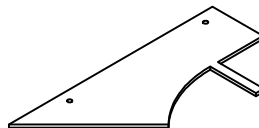

INSIDE CORNER PLATE
(24F261000)

WALL CONDITION	SPECIFIED FASTENER	DRILL DIAMETERS		C/S PART NUMBER
		WALL	RETAINER	
20 GA. STEEL STUD/GYPSUM WALL (HIGH LOAD)	1/4-20 X 5" S/S PHILLIPS PAN HEAD MACHINE SCREW 1/4" S/S TOGGLER WING 1/4" LOCK WASHER 1/4" FLAT WASHER	1/2"	9/32"	90H872004 90H873004 90H006003 90H007003

HRB-4CCMHLN HANDRAIL

LAYOUT VIEW

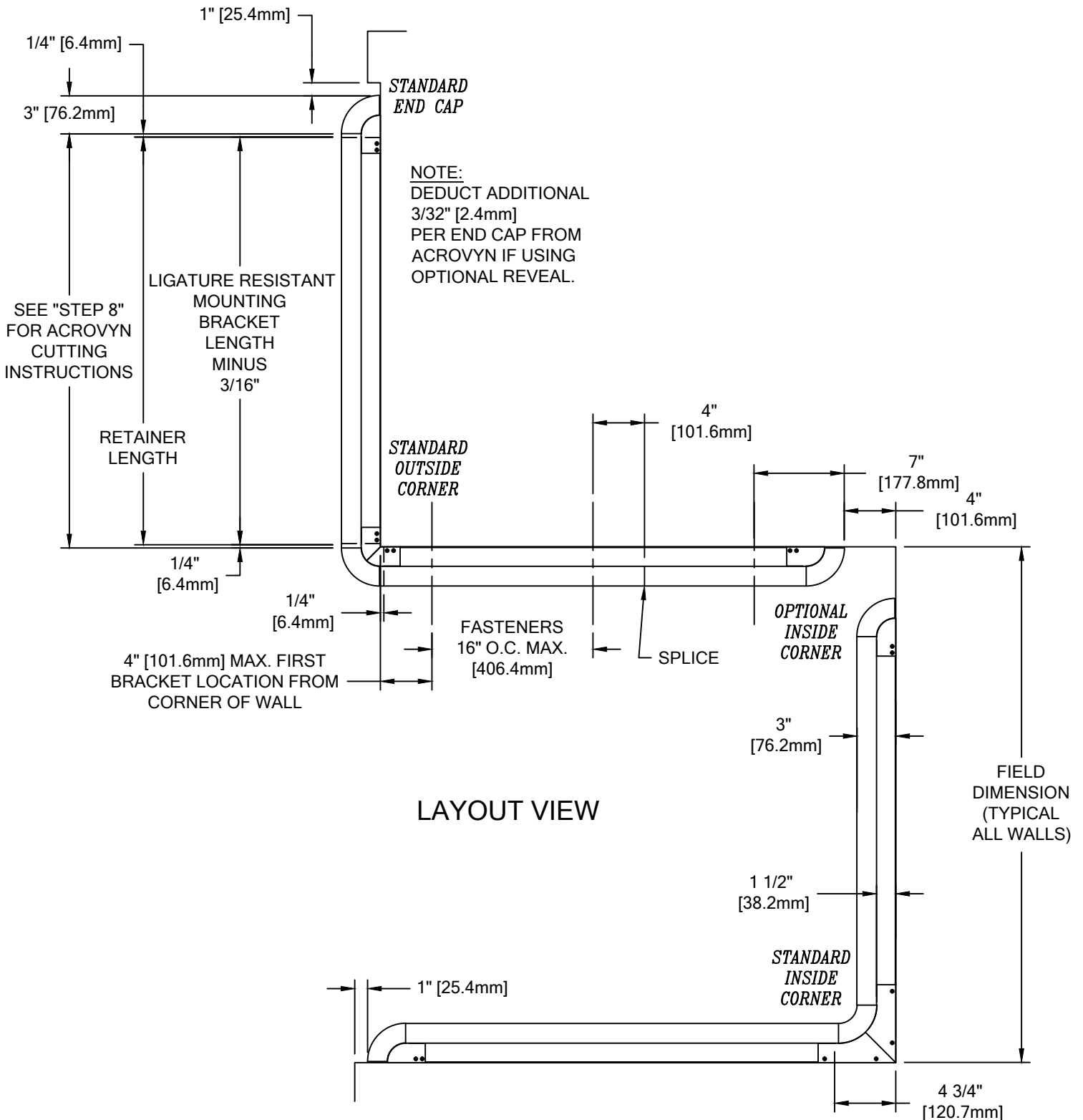

HRB-4CCMHLN HANDRAIL

TYPICAL ASSEMBLY

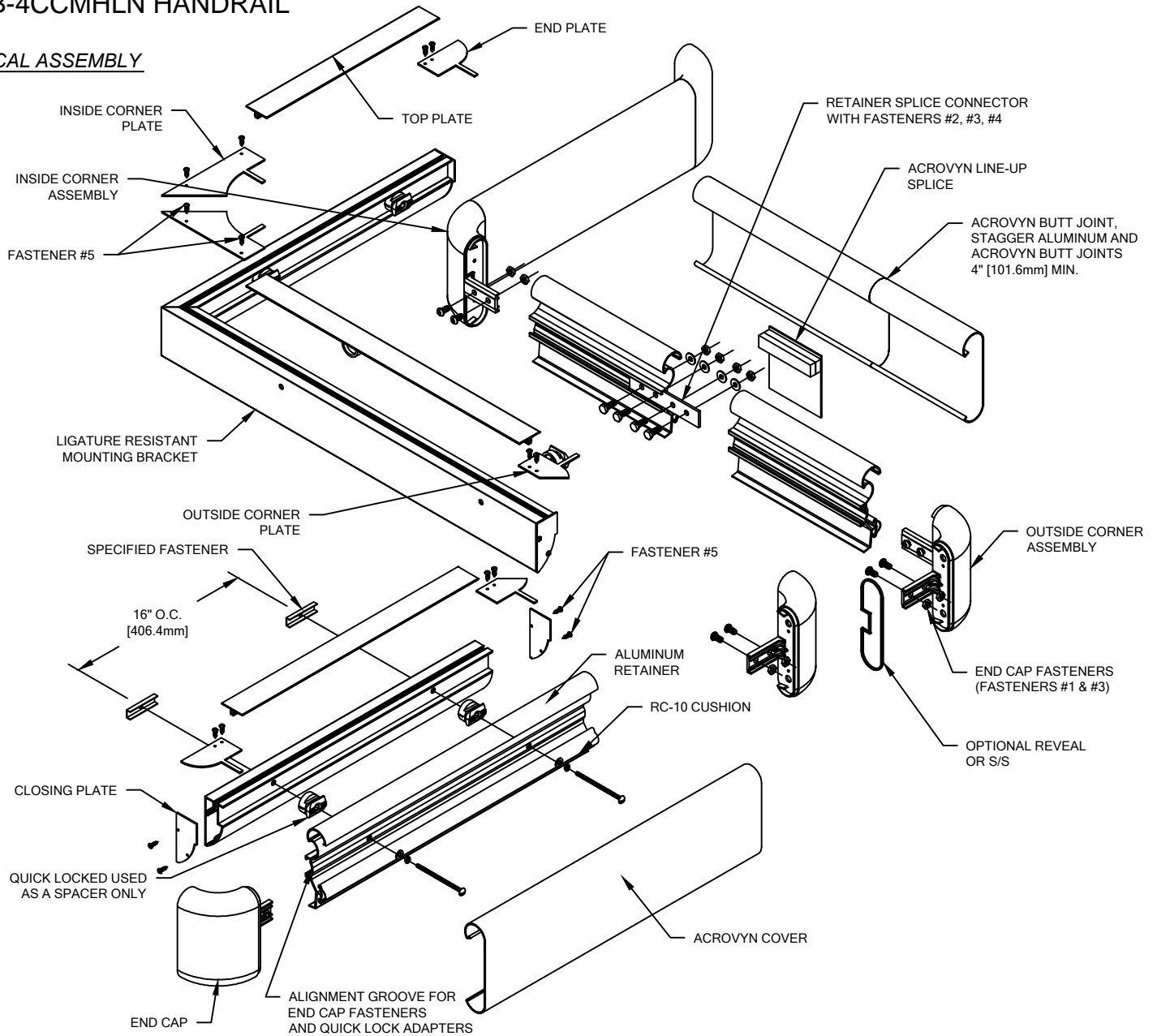

1. USING LOCAL CODE REQUIREMENTS, ESTABLISH HANDRAIL ABOVE FINISH FLOOR. DEDUCT 2 3/4" [69.8mm] AND SNAP A CHALK LINE AT THAT HEIGHT. THIS MARKS THE LOCATION OF THE FASTENERS FOR THE HANDRAIL BRACKETS.
2. CUT THE CONTINUOUS ALUMINUM RETAINER TO LENGTH USING THE REQUIRED DEDUCTIONS AS NOTED (SEE LAYOUT VIEW). PRE-DRILL CLEARANCE HOLES FOR THE SPECIFIED WALL FASTENERS IN THE ALUMINUM RETAINER 4" [101.4mm] FROM EACH END. REFERENCE CHART ON PAGE 2 FOR CORRECT DRILL DIAMETERS. ALL OTHER BRACKET HOLES MUST NOT EXCEED 16" [406.4mm] ON CENTER.
3. CUT THE LIGATURE RESISTANT MOUNTING BRACKET TO LENGTH USING THE REQUIRED DEDUCTIONS AS NOTED (SEE LAYOUT VIEW). ATTACH ONE CLOSING PLATE WITH TWO (2) #6 X 1/2" TAMPER-RESISTANT SHEET METAL SCREWS TO EACH END OF THE LIGATURE RESISTANT BRACKET BEFORE ATTACHING TO THE WALL.

NOTE: IT IS RECOMMENDED THAT THE ACROVYN COVERS AND ALUMINUM RETAINER BE CUT WITH AN 80-100 TOOTH CARBIDE TIPPED SAW BLADE OR EQUIVALENT.

4. DRILL CLEARANCE HOLES IN MOUNTING BRACKET AND WALL SURFACE FOR MOUNTING HARDWARE, USING THE RETAINER AS A TEMPLATE. REFERENCE CHART ON PAGE 2 FOR CORRECT DRILL DIAMETERS.

NOTE: FASTENERS MUST BE ENGAGED IN BOTH THE STRAPPING AND STUDS.

HRB-4CCMHLN HANDRAIL

END CAP & CORNER ASSEMBLY INSTALLATION

NOTE: INSTALLATION OF OUTSIDE CORNER ASSEMBLY SHOWN FROM THE BACKSIDE FOR CLARITY. INSIDE CORNERS AND STANDARD END CAPS SIMILAR.

ILLUSTRATION 1

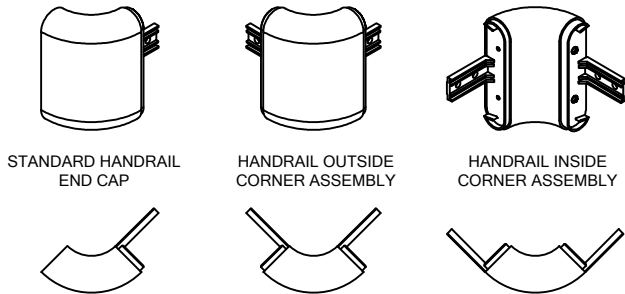

ILLUSTRATION 2

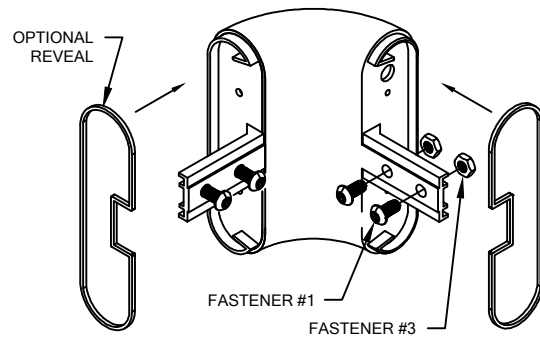

ILLUSTRATION 3

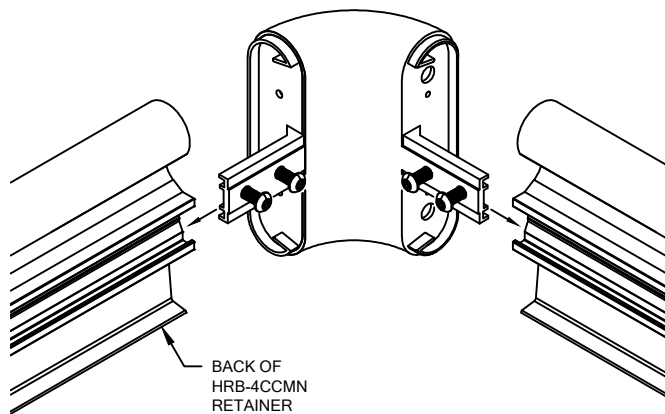
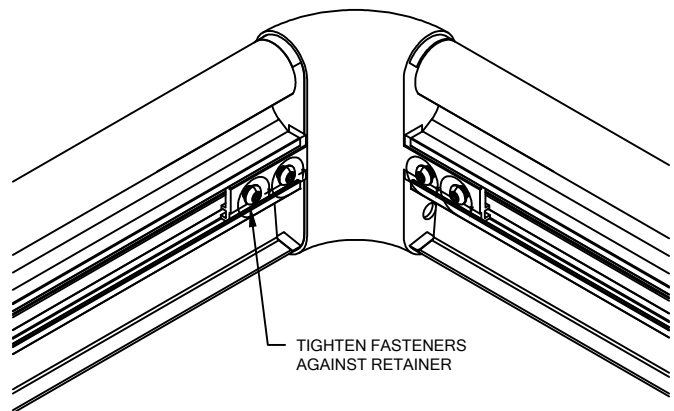

ILLUSTRATION 4



NOTE: IF END CAPS REVEALS ARE INCLUDED, FIT THEM OVER THE SHOULDERS OF THE END CAPS / CORNER ASSEMBLIES AT THIS TIME.

- ATTACH END CAPS AND/OR CORNER ASSEMBLIES BY LOOSELY THREADING TWO (2) 1/4-20 X 1/2" BUTTON SOCKET HEAD CAP SCREWS THROUGH THE BACKSIDE OF THE FLANGE OF EACH END CAP (FOUR (4) PER CORNER ASSEMBLY) INTO THEIR RESPECTIVE NUTS ON THE RETAINER SIDE OF THE FLANGE. SLIDE THE FLANGE INTO THE RECEIVER CHANNEL OF THE ALUMINUM RETAINER AND TIGHTEN THE BUTTON SOCKET HEAD CAP SCREWS FOR A SECURE FIT. SEE ILLUSTRATIONS 2 THROUGH 4.

NOTE: TO AID IN LOCATING THE END CAPS CORRECTLY, CUT A 4" [101.6mm] SECTION OF COVER FROM SCRAP AND SNAP IT ON THE RETAINER. LOCATE THE CAP SO IT ALIGNS FLUSH WITH TOP AND BOTTOM OF THE COVER.

- INSTALL EACH SECTION OF ASSEMBLED RETAINER IN SUCCESSION USING THE LIGATURE RESISTANT MOUNTING BRACKET AND THE APPROPRIATE WALL FASTENERS.

NOTE: HANDRAILS SHOULD BE BOLTED TO MOUNTING BRACKETS THROUGH THE FACE OF THE ALUMINUM RETAINER USING THE QUICK LOCK AS A SPACER.

- CUT THE RC-10 CUSHION TO LENGTH NOTING THE REQUIRED DEDUCTIONS (SEE LAYOUT VIEW) AND INSTALL ONTO THE ALUMINUM RETAINER.
- CUT THE ACROVYN COVERS TO THE PROPER LENGTH. THE COVER LENGTH IS DETERMINED BY MEASURING THE DISTANCE BETWEEN THE INSTALLED END CAPS AND/OR INSIDE/OUTSIDE CORNER ASSEMBLIES.

NOTE: IT IS RECOMMENDED THAT THE ACROVYN COVERS BE CUT SLIGHTLY LONGER (1/32" UP TO 5'-0", 1/16" OVER 5'-0") THAN THE MEASURED DISTANCE. THIS ADDITIONAL LENGTH WILL PROVIDE FOR A TIGHTER COVER-TO-END CAP FIT.

- ALIGN THE TOP OF THE ACROVYN COVER WITH THE TOP OF THE ALUMINUM RETAINER AND SNAP THE COVER ONTO THE RETAINER.

NOTE: MANUFACTURER RECOMMENDS ALL PRINTED "PRODUCT IDENTIFICATION" ON THE REAR OF THE ACROVYN PROFILE SHALL BE ORIENTED IN THE SAME DIRECTION DURING INSTALLATION TO ENSURE PROPER ALIGNMENT AT SPLICE BUTT JOINTS.

HRB-4CCMHLN HANDRAIL

END CAP & CORNER ASSEMBLY INSTALLATION

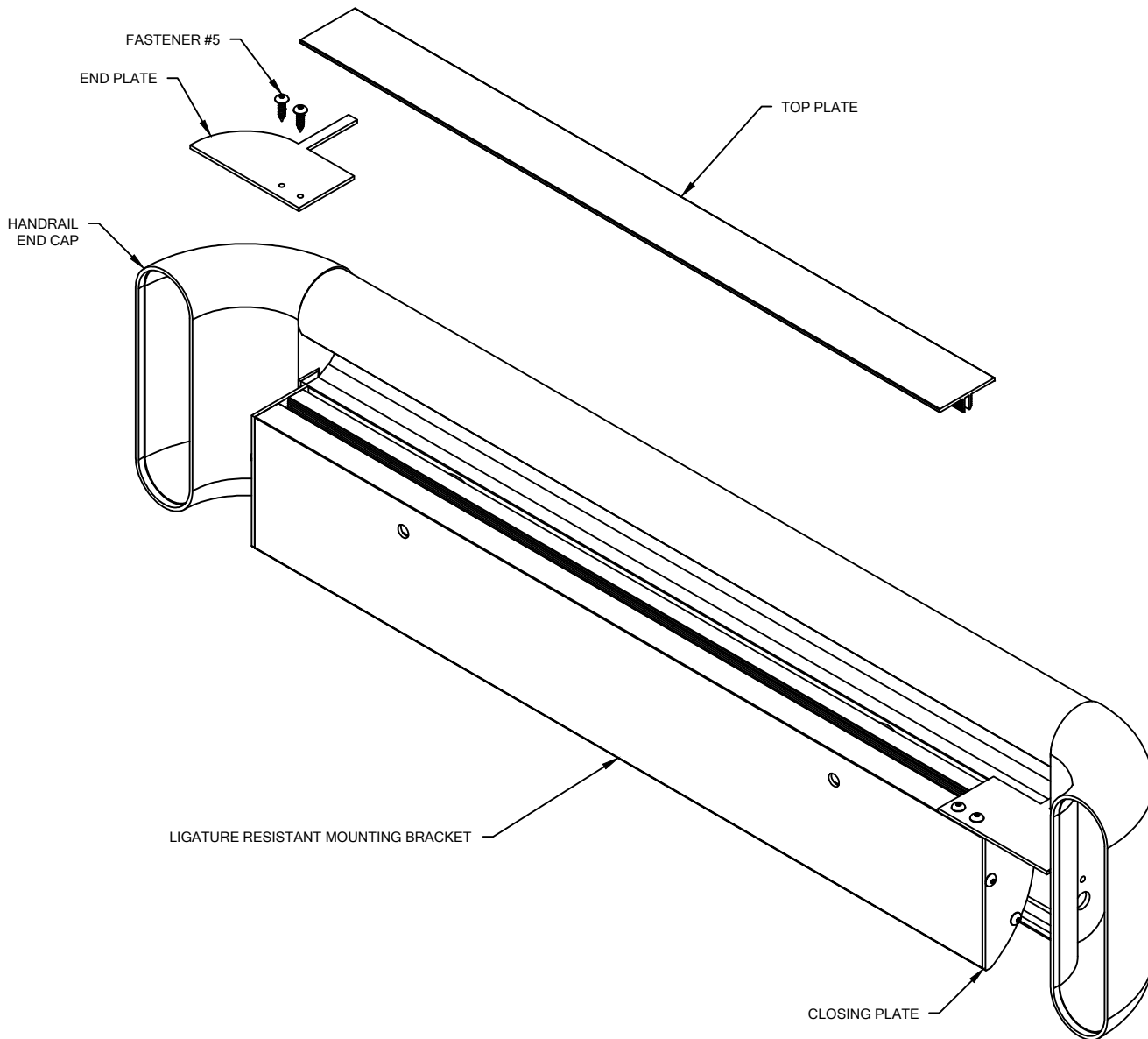

10. USING THE END PLATE/OUTSIDE CORNER PLATE AS A TEMPLATE, MARK THE HOLE LOCATIONS AND DRILL 5/32" PILOT HOLES. INSTALL THE END PLATE WITH TWO (2) #6 X 1/2" TAMPER-RESISTANT SHEET METAL SCREWS (FOUR (4) PER OUTSIDE CORNER PLATE).
11. CUT THE CONTINUOUS TOP PLATE TO THE PROPER LENGTH BY MEASURING THE DISTANCE BETWEEN THE INSTALLED END PLATES AND/OR OUTSIDE CORNER PLATE.
12. INSTALL THE CONTINUOUS TOP PLATE ONTO THE LIGATURE RESISTANT BRACKET BETWEEN THE INSTALLED END PLATES AND/OR OUTSIDE CORNER PLATE.
13. PLACE A WOOD BLOCK ON TOP OF THE CONTINUOUS TOP PLATE. WHILE HOLDING THE CONTINUOUS TOP PLATE SOMEWHAT LEVEL, USE A RUBBER MALLETT TO STRIKE THE WOOD BLOCK. (NOTE: DO NOT HAMMER DIRECTLY ONTO THE CONTINUOUS TOP PLATE AS THIS MAY CAUSE DAMAGE TO THE CONTINUOUS TOP PLATE.)
14. WORK DOWN ALONG THE LENGTH OF THE CONTINUOUS TOP PLATE DRIVING THE TOP PLATE APPROXIMATELY HALF ONTO THE LIGATURE RESISTANT BRACKET. RETURN AND DRIVE THE CONTINUOUS TOP PLATE THE REMAINDER OF THE WAY IN UNTIL IT IS SEATED FLUSH WITH THE END PLATES AND/OR OUTSIDE CORNER PLATE.

3/20/15