

COLOR: _____
 HANDRAIL WOOD SPECIES: _____
 HANDRAIL WOOD FINISH: _____
 COLOR TO BE SELECTED FROM ONE OF CS STANDARD COLORS.
 FEATURE INSERT COLOR: _____
 REFER TO CS CATALOG FOR FEATURE INSERT COLORS.

TOTAL L/F REQ'D	LEFT END CAPS	RIGHT END CAPS

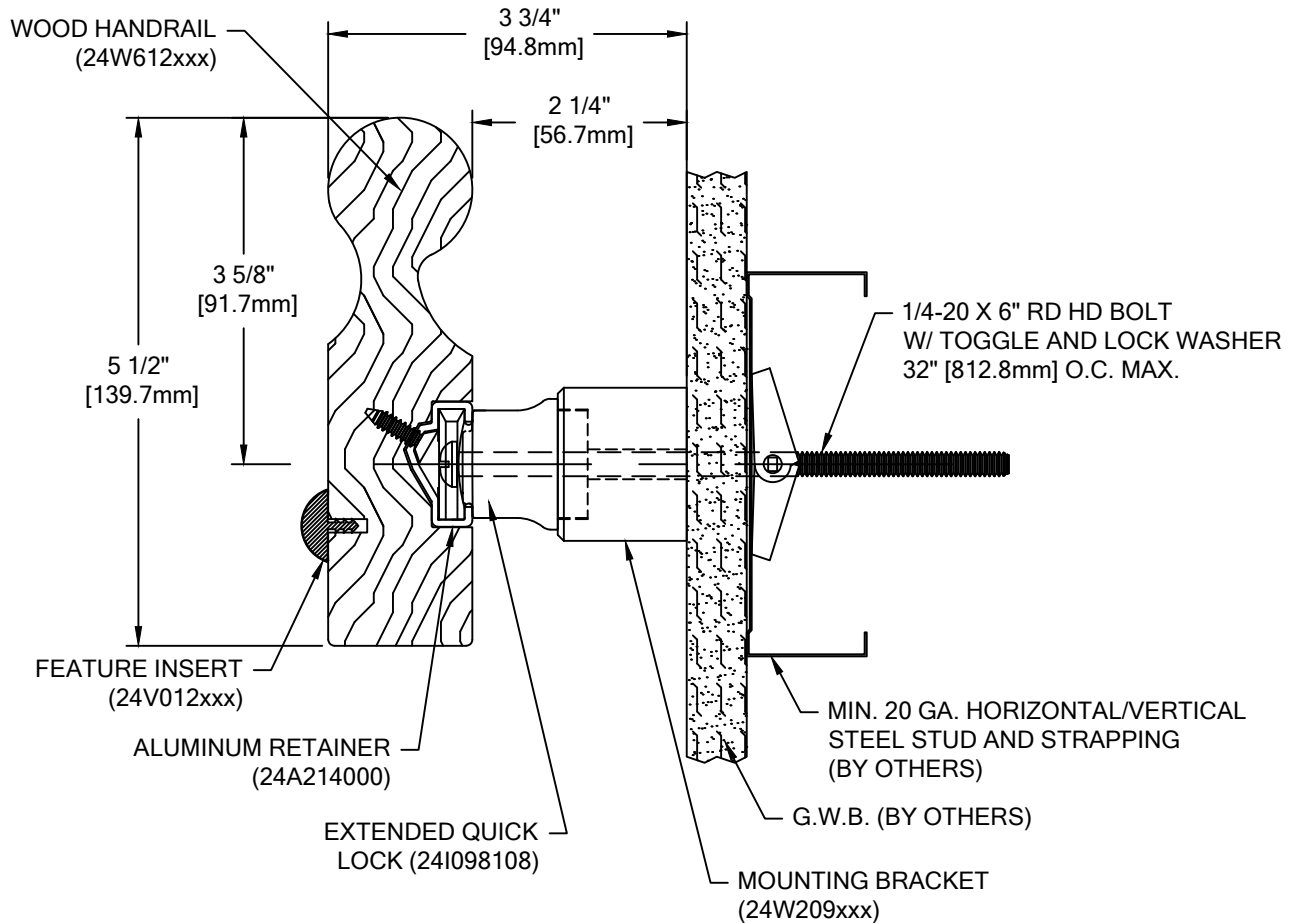

AW-10CVB WITH INTERNATIONAL OFFSET

FABRICATION AND APPEARANCE OF THIS WOOD RAIL MATERIAL IS BASED ON FACTORY CUT AND ATTACHED END CAPS. IF STOCK SIZES ARE REQUIRED, END CAPS MUST BE CUT IN THE FIELD BY INSTALLER OR CS WILL NOT GUARANTEE MATCH AND APPEARANCE OF CAPS TO RAIL.

WALL CONDITION	SPECIFIED FASTENER	DRILL DIAMETERS		CS PART NUMBER
		WALL	RETAINER	
STEEL STUD/GYPSUM WALL	1/4-20 X 5" ROUND HEAD BOLT WITH TOGGLE, AND LOCK WASHER	3/4"	9/32"	90H049002 90H006003
CONCRETE/CONCRETE BLOCK	#14 X 5" PHILLIPS RD HD ALL-PURPOSE SCREW	3/16"	9/32"	90H287006
WOOD STUD/GYPSUM WALL	#14 X 5" PHILLIPS RD HD ALL-PURPOSE SCREW	1/8"	9/32"	90H287006

 <p>Hughesville, PA 800.233.8493 570.546.5941 Mississauga, ON 888.895.8955 905.274.3611 www.c-sgroup.com</p> <p>© Copyright 2017 Construction Specialties, Inc.</p>	PROJECT:	REVISION:
	JOB NO.:	F&F:
	CUSTOMER:	DATE:
	REP:	SHEET NO:
	DRAWN BY:	