

FWF-M & FWFC-M 300-600

TECHNICAL DATA:

Aluminum

- Extrusion – CS uses multiple alloys & tempers which are established to be the most appropriate for the given use of individual parts. Will be one of the following: (6063-T5, T6, T52) (6061-T5, T6, T51) (6105-T5, T6) (6005-T5) (6005A-T5, T61), ASTM B221
- Aluminum in contact with concrete/masonry will have a 2 mil heavy metal free high solids primer

Seal

- Material: Santoprene-TPV 8201-70 (Colors 232 White, 270 Greige, 764 Platinum)
Santoprene-TPV 8221-70 (Colors 108 Black, 136 Gray)
- Single Durometer: 75 Shore-A, ASTM D2240

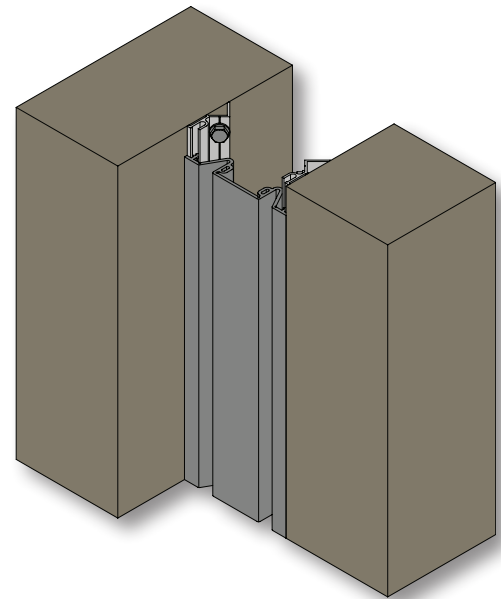

MODEL	JOINT WIDTH	MINIMUM OPENING	MAXIMUM OPENING	EXPOSED SURFACE	BLOCKOUT WIDTH	BLOCKOUT HEIGHT
FWF-300M	3.00" (76mm)	1.25" (32mm)	4.50" (114mm)	3.00" (76mm)	N/A	N/A
FWF-400M	4.00" (102mm)	1.25" (32mm)	6.00" (152mm)	4.00" (102mm)	N/A	N/A
FWF-500M	5.00" (127mm)	1.25" (32mm)	7.50" (191mm)	5.00" (127mm)	N/A	N/A
FWF-600M	6.00" (152mm)	1.75" (44mm)	9.00" (229mm)	6.00" (152mm)	N/A	N/A
FWFC-300M	3.00" (76mm)	1.25" (32mm)	4.50" (114mm)	3.00" (76mm)	N/A	N/A
FWFC-400M	4.00" (102mm)	1.25" (32mm)	6.00" (152mm)	4.00" (102mm)	N/A	N/A
FWFC-500M	5.00" (127mm)	1.25" (32mm)	7.50" (191mm)	5.00" (127mm)	N/A	N/A
FWFC-600M	6.00" (152mm)	1.75" (44mm)	9.00" (229mm)	6.00" (152mm)	N/A	N/A

Note: FWF/FWFC-600M Frames differ in design.

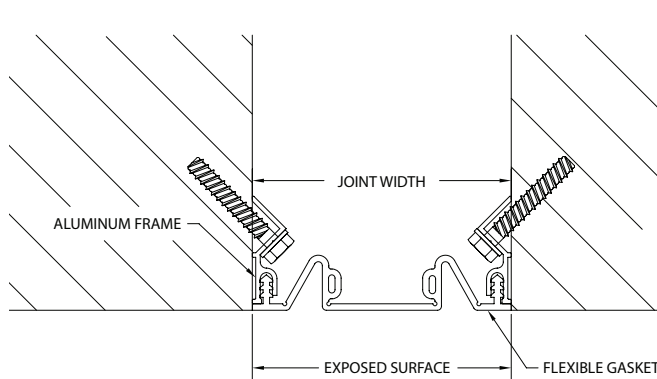

FWF-M

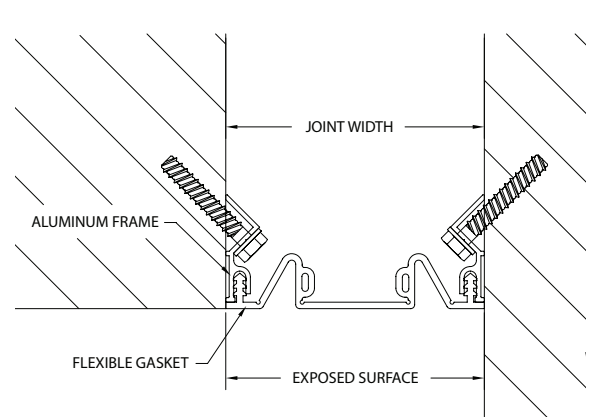

FWFC-M