

SC 1100-1600 Series

TECHNICAL DATA:

Aluminum

- Extrusion – CS uses multiple alloys & tempers which are established to be the most appropriate for the given use of individual parts. Will be one of the following: (6063-T5, T6, T52) (6061-T5, T6, T51) (6105-T5, T6) (6005-T5) (6005A-T5, T61), ASTM B221

Primary Seal

- Material: Santoprene-TPV 8221-70 (All Standard Colors)
- Single Durometer: 75 Shore-A, ASTM D2240
- Brittle Point: -76°F
- Ozone Resistance: No Cracks, ASTM D1149
- UV Resistance: Very Good

Vapor Barrier

- Material: 7-Ply Polyethylene, ASTM-E-1745-11
- Color: Black
- 3" Tensile Strength: 275 lbs., ASTM-D-882
- Puncture Strength: 79 lbs., ASTM-D-4833
- PPT Resistance: 62 lbs., ASTM-D-2582

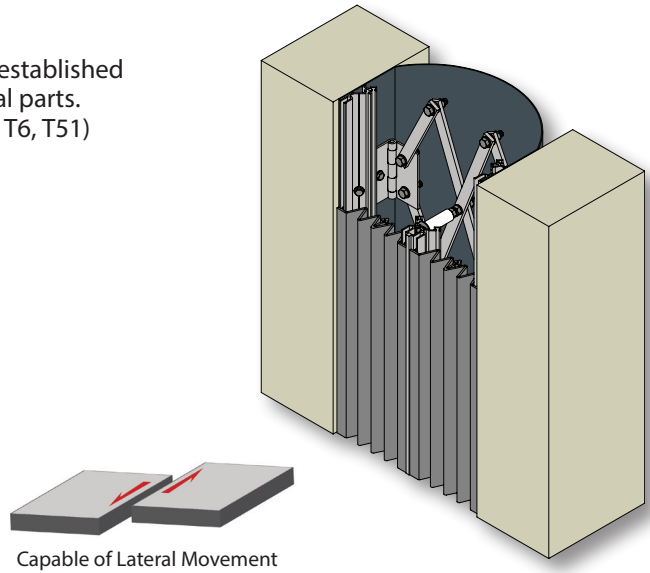

MODEL	JOINT WIDTH	MINIMUM OPENING	MAXIMUM OPENING	EXPOSED SURFACE	BLOCKOUT WIDTH	BLOCKOUT HEIGHT
SC-1100	11.00" (279mm)	6.00" (152mm)	22.00" (559mm)	11.00" (279mm)	N/A	N/A
SC-1200	12.00" (305mm)	6.00" (152mm)	24.00" (610mm)	12.00" (305mm)	N/A	N/A
SC-1300	13.00" (330mm)	6.00" (152mm)	26.00" (660mm)	13.00" (330mm)	N/A	N/A
SC-1400	14.00" (356mm)	6.00" (152mm)	28.00" (711mm)	14.00" (356mm)	N/A	N/A
SC-1500	15.00" (381mm)	6.00" (152mm)	30.00" (762mm)	15.00" (381mm)	N/A	N/A
SC-1600	16.00" (406mm)	6.00" (152mm)	32.00" (813mm)	16.00" (406mm)	N/A	N/A

Contact factory for larger sizes.

