

HRBW-20CMN HANDRAIL

WITH LIGATURE RESISTANT MOUNTING BRACKET

PLEASE READ

PLEASE READ THESE INSTRUCTIONS THOROUGHLY PRIOR TO BEGINNING THE HRBW-20CMN HANDRAIL INSTALLATION!

THIS INSTRUCTION SHEET IS INTENDED TO PROVIDE A SPECIFIC GUIDE TO FOLLOW FOR THE INSTALLATION OF THIS HRBW-20CMN HANDRAIL. CONTAINED WITHIN IS THE TECHNICAL INFORMATION AND INSTALLATION TECHNIQUES REQUIRED TO COMPLETE AN EFFICIENT, NEAT AND LONG-LASTING INSTALLATION.

INSPECT ALL MATERIALS FOR DAMAGE OR MISSING PARTS. IF YOU DISCOVER DAMAGED OR MISSING MATERIALS, IN THE USA PLEASE NOTIFY THE FACTORY AT (800) 233-8493, AND IN CANADA (888) 895-8955 FOR CUSTOMER SERVICE.

HRBW-20CMN HANDRAIL MUST BE INSTALLED IN ACCORDANCE WITH THESE INSTRUCTIONS! FAILURE TO FOLLOW THESE INSTRUCTIONS MAY VOID ANY PRODUCT WARRANTIES AND RESULT IN AN UNSUCCESSFUL INSTALLATION. FOR SPECIFIC QUESTIONS REGARDING THE INSTALLATION OF THIS HRBW-20CMN HANDRAIL PLEASE CALL THE FACTORY IN THE USA AT (800) 233-8493 OR EMAIL IWPTECHSUPPORT@C-SGROUP.COM. IN CANADA CALL (888) 895-8955 .

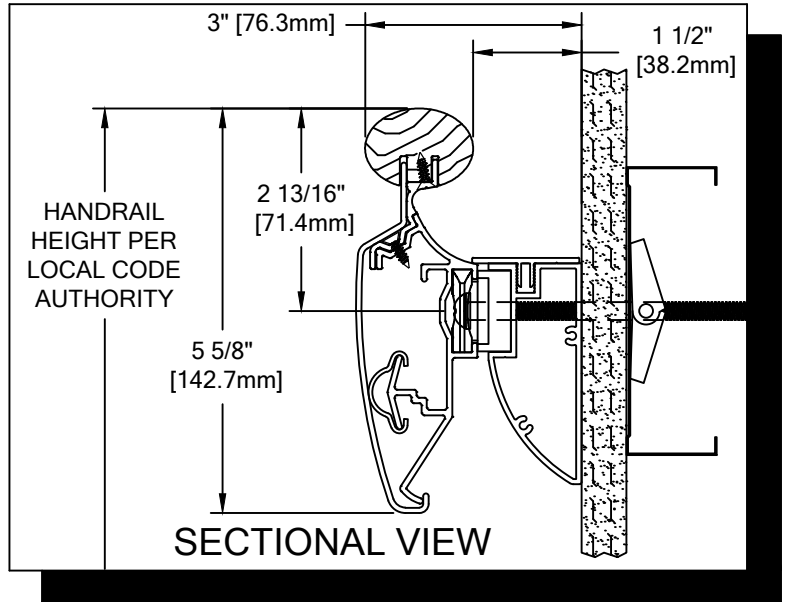

IMPORTANT NOTES

1. DUE TO WOOD BEING A NATURAL PRODUCT, COMPONENTS MAY GROW AND SHRINK AT DIFFERENT RATES. BECAUSE OF THIS, C/S HAS DESIGNED THIS HANDRAIL TO UTILIZE A BEVEL AS SHOWN IN THESE INSTRUCTIONS (SEE ILLUSTRATION 3). THIS BEVEL MUST BE APPLIED AT ALL WOOD JOINTS AND MUST MATCH FACTORY BEVEL ON END CAPS.
2. DUE TO THE NATURE OF WOOD, COMPONENT COLORS MAY VARY, SORT WOOD COMPONENTS AND MATCH PARTS BY COLOR.
3. ALL LINEAL MATERIAL TO BE SUPPLIED IN STOCK LENGTHS. WOOD IN 7'-0" TO 12'-0" VARIABLE, AND ALUMINUM AND ACROVYN IN LENGTHS UP TO 20'-0". THIS MATERIAL IS TO BE FIELD CUT USING QUALITY EQUIPMENT TO INSURE THAT ALL CUTS ARE SQUARE. WHEN CUTTING MATERIAL SECTIONS, C/S RECOMMENDS USING AN 80-100 TOOTH CARBIDE TIPPED SAW BLADE OR EQUIVALENT, TO MINIMIZE CHIPPING AND MAINTAIN JOINT ALIGNMENT.
4. ALL DIMENSIONS ARE TYPICAL.
5. FOR DRYWALL/PLASTER WALL CONSTRUCTION, IT IS RECOMMENDED FOR FASTENERS TO BE ENGAGED INTO METAL/WOOD STUDS TO MAINTAIN MAXIMUM PULLOUT STRENGTH.
6. INSTALL OUTSIDE CORNERS FIRST.
7. INSTALL LONGEST RUN OF HANDRAIL FIRST.
8. ALUMINUM RETAINER SPLICE SHOULD NOT EXCEED 4" [101.6mm] DISTANCE FROM A BRACKET.
9. THE DISTANCE BETWEEN AN ACROVYN SPLICE JOINT AND AN ALUMINUM RETAINER SPLICE JOINT SHOULD BE STAGGERED 4" [101.6mm].
10. MATERIAL MUST REACH 65°F MIN. TO 75°F MAX. 24 HOURS PRIOR TO INSTALLATION. THIS IS ESSENTIAL TO MINIMIZE EXPANSION AND CONTRACTION OF MATERIAL.
11. MAY REQUIRE USE OF FIRE PUTTY WHEN INSTALLED ON FIRE WALL WITH TOGGLE BOLTS. REFERENCE INSTRUCTIONS 24FIREPUTTY FOR FIRE PUTTY INSTALLATION.
12. THIS HANDRAIL REQUIRES A MINIMUM OF 2 MOUNTING BRACKETS PER UNIT. THE MINIMUM END CAP-TO-END CAP HANDRAIL LENGTH IS 17" [431.8mm].
13. FOR MORE INFORMATION ON HRBW-20CMN HANDRAIL SEE OUT WEBSITE AT www.c-sgroup.com.

HRBW-20CMN HANDRAIL

COMPONENTS & WALL FASTENERS

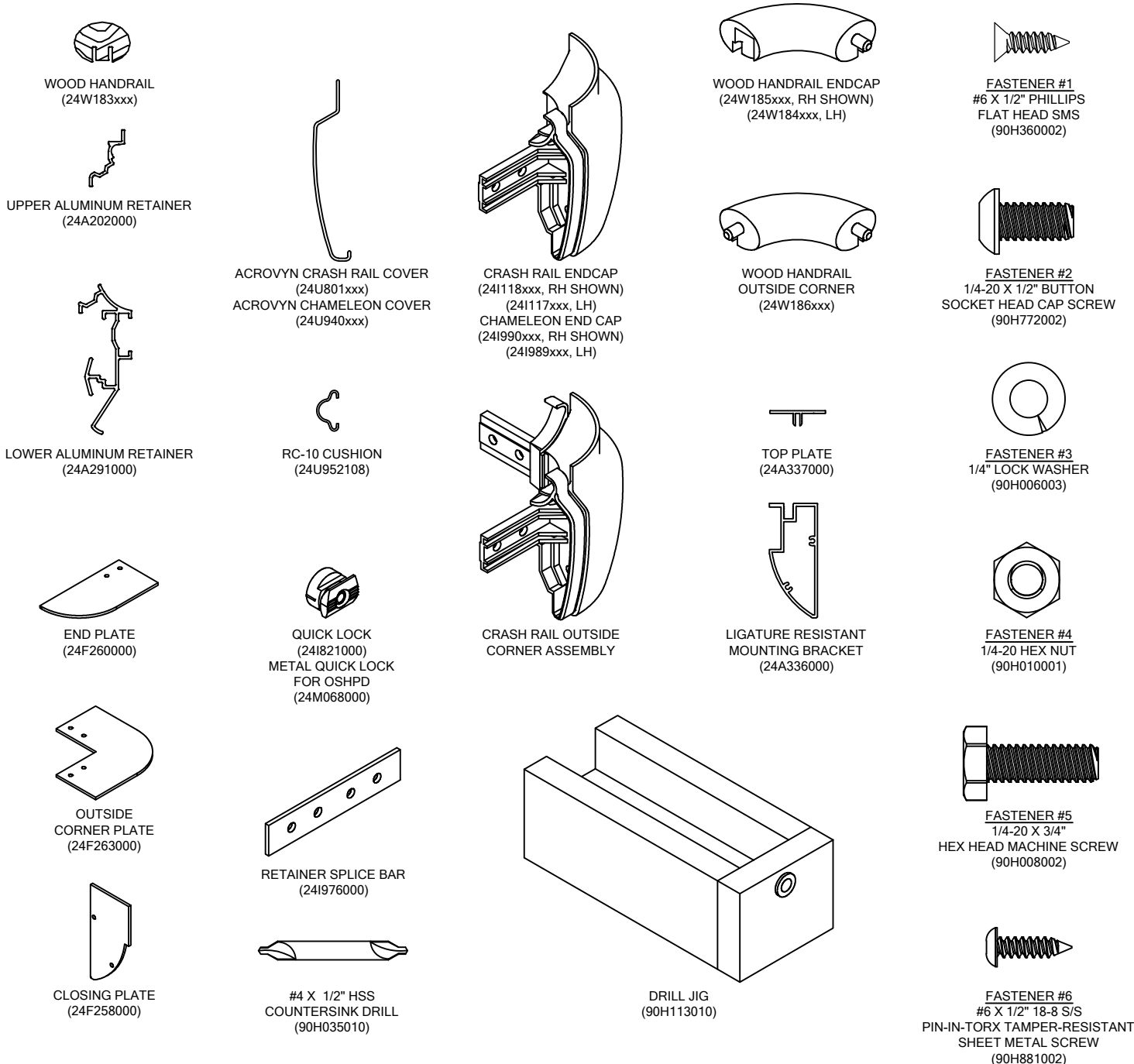

WALL CONDITION	SPECIFIED FASTENER	DRILL DIAMETERS		C/S PART NUMBER
		WALL	RETAINER	
STEEL STUD/GYPSUM WALL	1/4-20 X 5" ROUND HEAD BOLT WITH TOGGLE, AND LOCK WASHER	3/4"	N/A	90H049002 90H006003
CONCRETE/CONCRETE BLOCK	#14 X 5" PHILLIPS RD HD ALL-PURPOSE SCREW	3/16"	N/A	90H287002
WOOD STUD/GYPSUM WALL	#14 X 5" PHILLIPS RD HD ALL-PURPOSE SCREW	1/8"	N/A	90H287002
20 GA. STEEL STUD/GYPSUM WALL (OSHPD)	1/4-20 X 5" RD. HD. BOLT WITH FLAT WASHER 1/4" TOGGLER WING 3M MOLDABLE FIRE PUTTY	1/2"	N/A	90H659002 90H007003 90H062004 90M012000

HRBW-20CMN HANDRAIL

LAYOUT VIEW

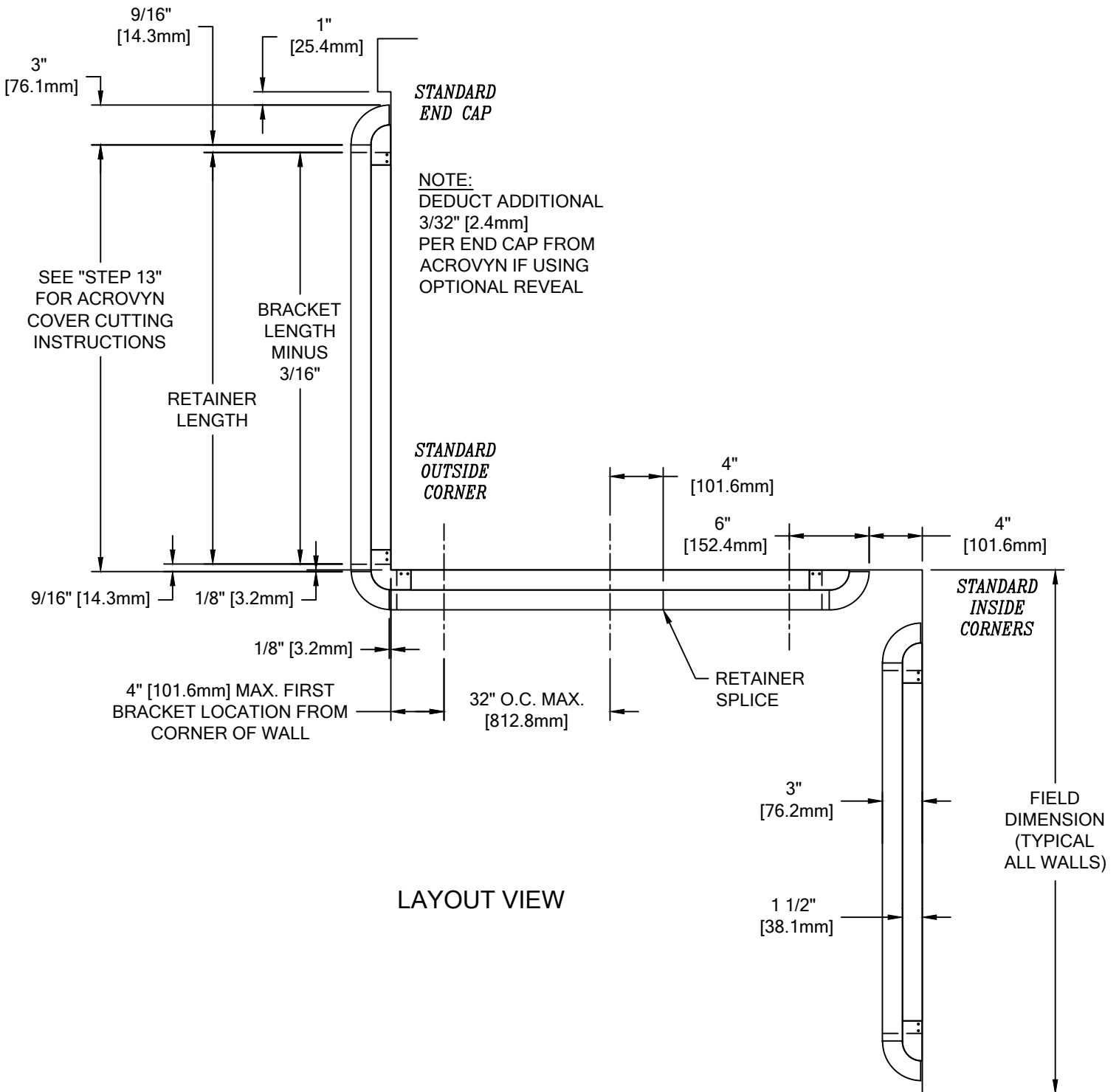

LAYOUT VIEW

HRBW-20CMN HANDRAIL

TYPICAL ASSEMBLY

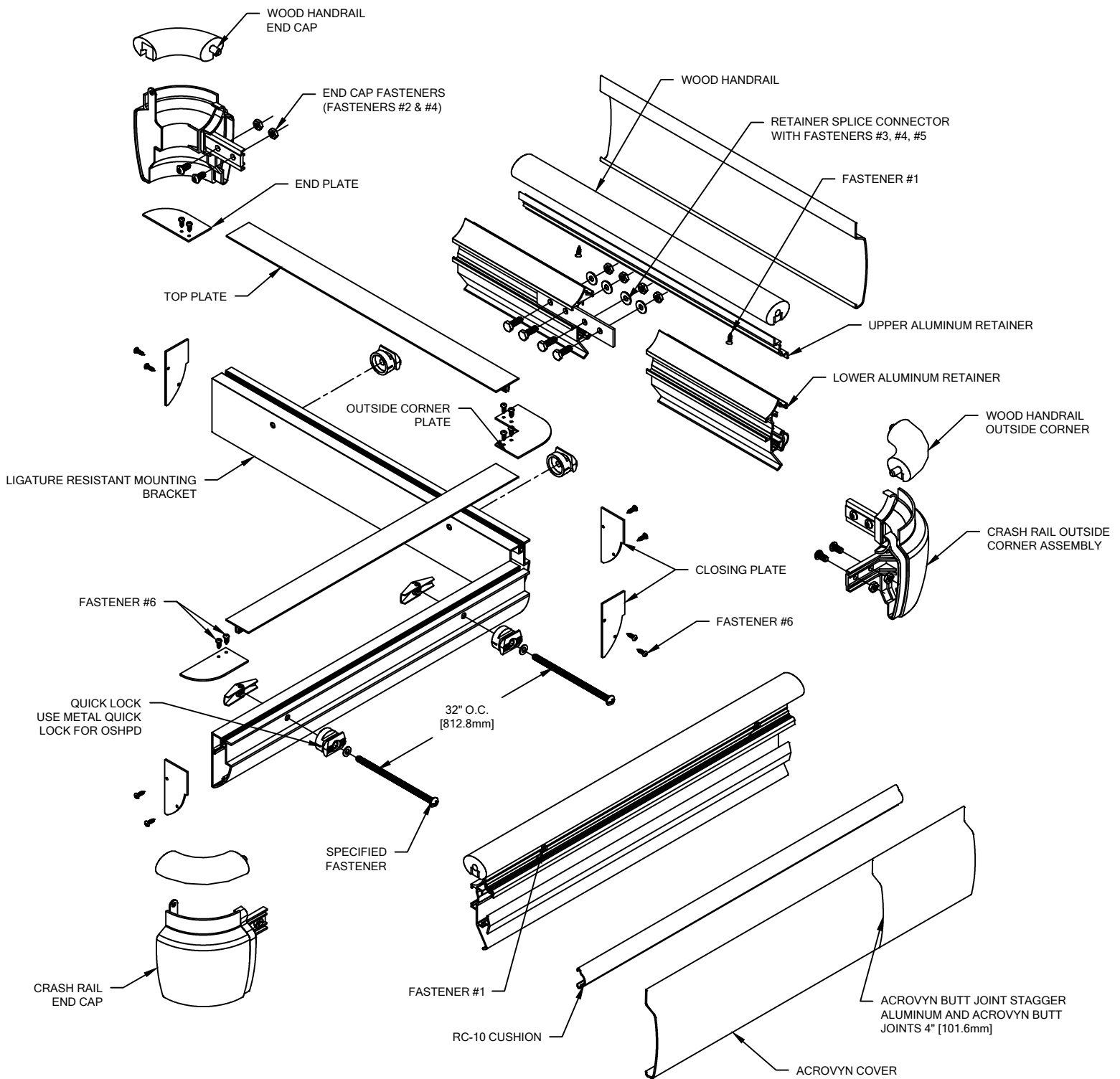

DUE TO THE NATURE OF WOOD, COMPONENT COLORS MAY VARY.
SORT WOOD COMPONENTS AND MATCH PARTS BY COLOR.

HRBW-20CMN HANDRAIL

1. ESTABLISH HANDRAIL HEIGHT ABOVE FINISH FLOOR. DEDUCT 2 13/16" [71.4mm] AND SNAP A CHALK LINE AT THAT HEIGHT. THIS MARKS THE LOCATION OF THE FASTENERS FOR THE HANDRAIL BRACKETS.
2. CUT THE LIGATURE RESISTANT MOUNTING BRACKET TO LENGTH USING THE REQUIRED DEDUCTIONS (SEE LAYOUT VIEW). PRE-DRILL CLEARANCE HOLES FOR THE SPECIFIED WALL FASTENERS IN THE LIGATURE RESISTANT MOUNTING BRACKET 3" [76.2mm] FROM EACH END. REFERENCE CHART ON PAGE 2 FOR CORRECT DRILL DIAMETERS. ALL OTHER BRACKET HOLES MUST NOT EXCEED 32" [812.8mm] ON CENTER. ATTACH ONE CLOSING PLATE WITH TWO (2) #6 x 1/2" TAMPER-RESISTANT SHEET METAL SCREWS TO EACH END OF THE LIGATURE RESISTANT BRACKET BEFORE ATTACHING TO THE WALL.
3. PLACE A QUICK LOCK INTO EACH MOUNTING BRACKET. USING THE APPROPRIATE FASTENERS, ATTACH THE BRACKET ASSEMBLIES TO WALL AT PRE-DRILLED LOCATIONS. IF INSTALLING OPTIONAL LIGATURE RESISTANT BRACKET ENCLOSURE, SEE ILLUSTRATION 4.

NOTE: IF YOUR ORDER IS A CUT-TO-SIZE JOB, GO TO STEP 5.

NOTE: IF YOUR ORDER IS A PRE-ASSEMBLED JOB, GO TO STEP 14.

4. CUT BOTH THE UPPER AND LOWER ALUMINUM RETAINER TO LENGTH USING THE REQUIRED DEDUCTIONS AS NOTED (SEE LAYOUT VIEW).

NOTE: IT IS RECOMMENDED THAT THE ACROVYN COVERS AND ALUMINUM RETAINER BE CUT WITH AN 80-100 TOOTH CARBIDE TIPPED SAW BLADE OR EQUIVALENT.

5. CUT THE RC-10 CUSHION TO LENGTH NOTING REQUIRED DEDUCTIONS (SEE LAYOUT VIEW) AND INSTALL ONTO ALUMINUM RETAINER.
6. ATTACH CRASH RAIL END CAPS/OUTSIDE CORNER ASSEMBLIES BY LOOSELY THREADING TWO (2) 1/4-20 X 1/2" BUTTON SOCKET HEAD CAP SCREWS THROUGH THE BACK SIDE OF THE FLANGE OF EACH END CAP (FOUR (4) PER CORNER ASSEMBLY) INTO THEIR RESPECTIVE NUTS ON THE RETAINER SIDE OF THE FLANGE. SLIDE THE FLANGE INTO THE RECEIVER CHANNEL OF THE LOWER ALUMINUM RETAINER AND TIGHTEN THE BUTTON SOCKET HEAD CAP SCREWS FOR A SECURE FIT. SEE ILLUSTRATIONS 1 AND 2.
7. CUT WOOD HANDRAIL TO LENGTH NOTING REQUIRED DEDUCTIONS (SEE LAYOUT VIEW). BEVEL THE CUT EDGES ON HANDRAIL END SLIGHTLY WITH 150 GRIT SANDPAPER TO MATCH BEVEL ON WOOD END CAPS (SEE ILLUSTRATION 3). TOUCH UP SANDED EDGES WITH STAIN MARKER.

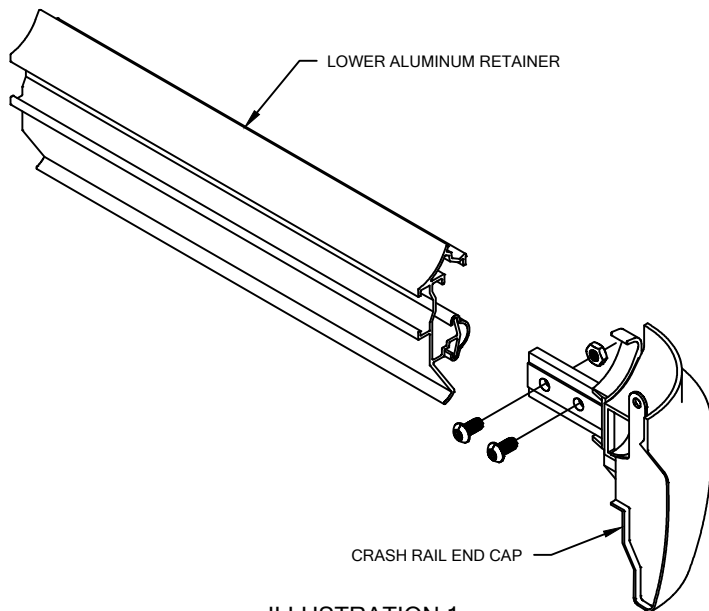

ILLUSTRATION 1

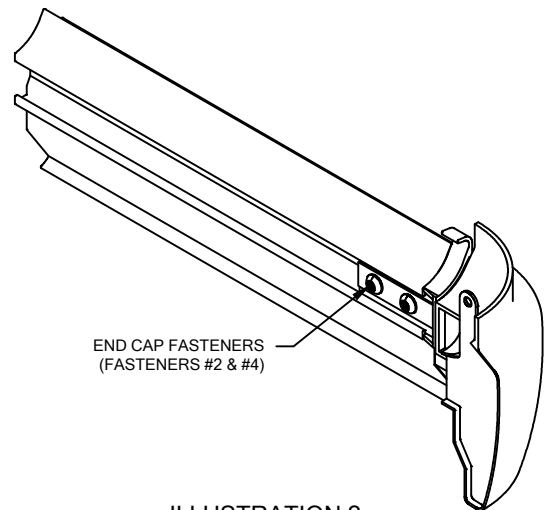

ILLUSTRATION 2

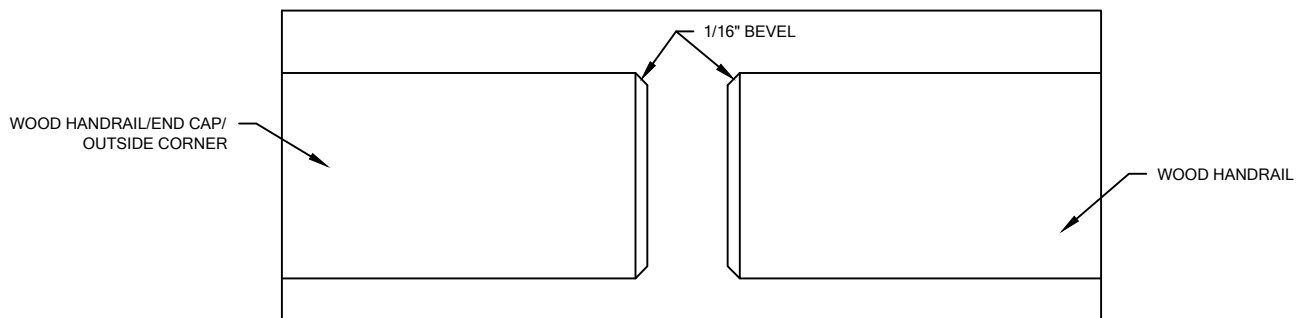
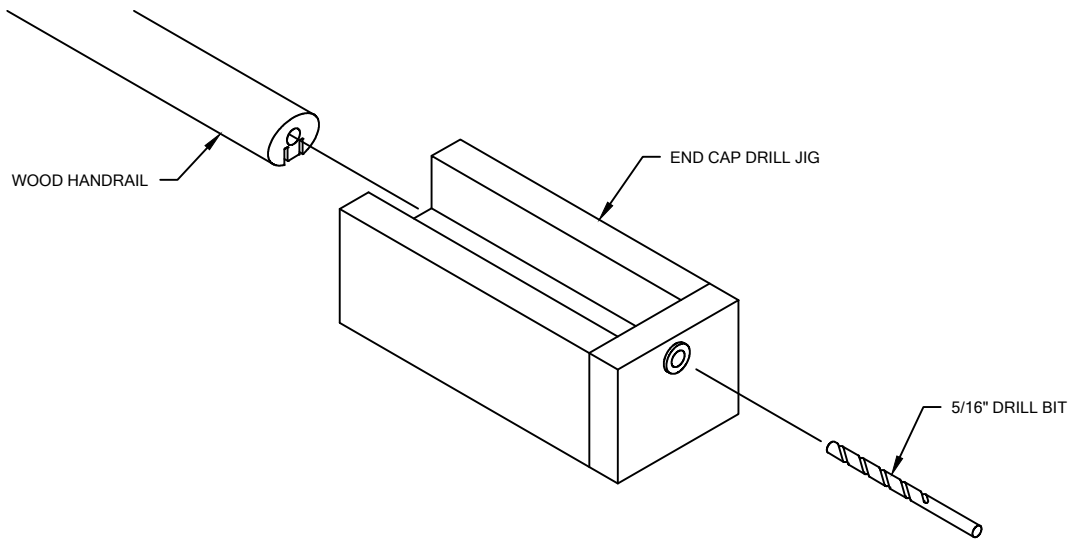
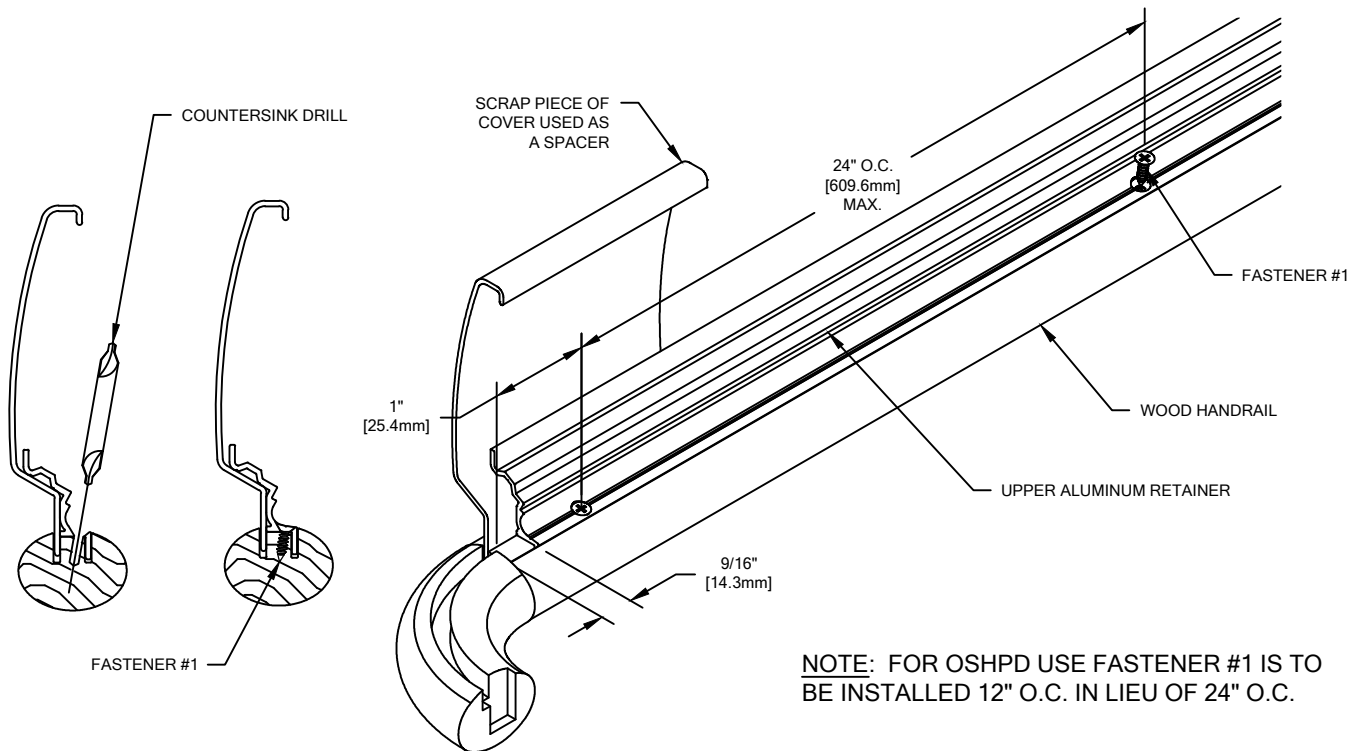

ILLUSTRATION 3

HRBW-20CMN HANDRAIL



8. TO ENSURE PROPER ALIGNMENT OF HANDRAIL TO END CAP, USE THE END CAP DRILL JIG TO DRILL A HOLE FOR DOWEL PIN IN EACH END OF THE HANDRAIL. SEE ILLUSTRATION ABOVE.
 - A. LOCATE HANDRAIL TIGHT AGAINST DRILL JIG'S BOTTOM DRILL BUSHING.
 - B. DRILL 5/16" PILOT HOLE, 7/8" DEEP, IN EACH END OF THE HANDRAIL.
 - C. CONTINUALLY CLEAN OUT WOOD CHIPS AS THE PILOT HOLE IS BEING DRILLED.
9. ATTACH WOOD END CAPS TO WOOD HANDRAIL BY SLIDING THE END CAP DOWEL INTO THE ALIGNMENT HOLE IN THE HANDRAIL. BEFORE APPLYING WOOD GLUE DRY FIT COMPONENTS TOGETHER TO DOUBLE CHECK FIT. APPLY WOOD GLUE INTO THE HOLE AND HROW-6 END SURFACE PRIOR TO END CAP INSERTION. TITEBOND WOOD GLUE IS RECOMMENDED FOR THIS APPLICATION. WIPE OFF ANY EXCESS GLUE.



10. FIT WOOD HANDRAIL WITH UPPER ALUMINUM RETAINER. WOOD RAIL SHOULD EXTEND PAST THE ENDS OF THE UPPER RETAINER BY 9/16". DRILL CLEARANCE HOLES USING THE SUPPLIED COUNTERSINK DRILL. CUT A PIECE OF GUARD FROM SCRAP TO USE AS A SPACER FOR PROPER ALIGNMENT OF UPPER RETAINER TO WOOD HANDRAIL. REFER TO ILLUSTRATION ABOVE. ATTACH TOP RAIL TO THE RETAINER USING THE SUPPLIED FASTENERS.

HRBW-20CMN HANDRAIL

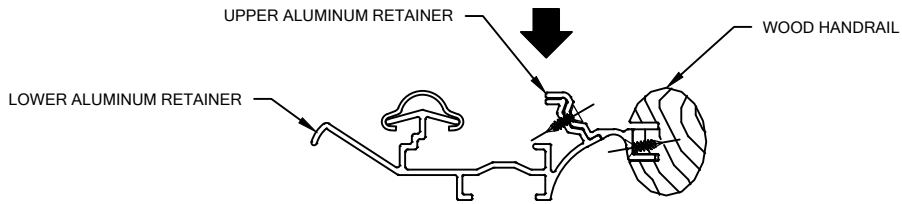

NOTE:
WHEN DRILLING APPLY PRESSURE AS INDICATED IN ILLUSTRATION IN ORDER TO ACHIEVE PROPER FIT.

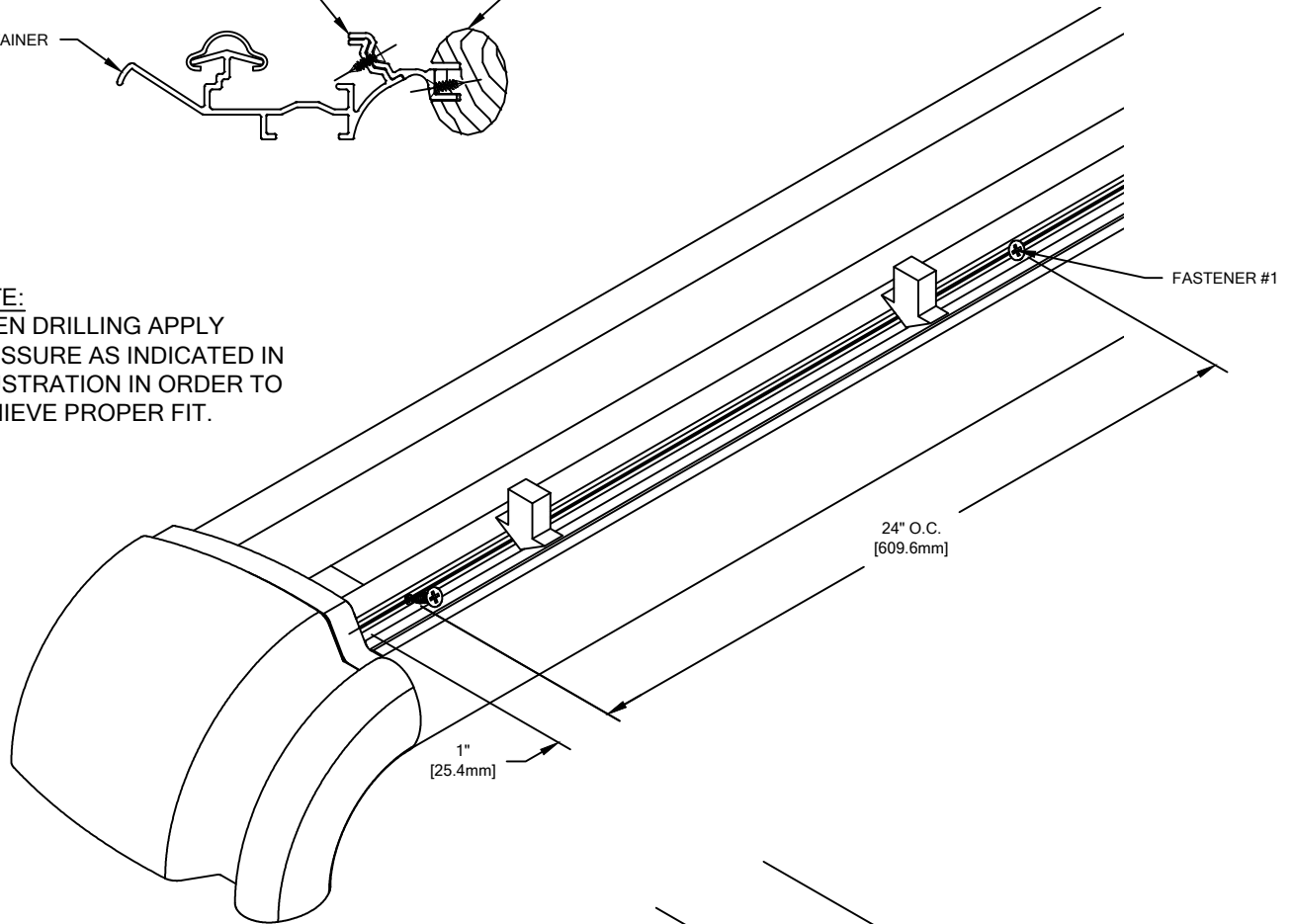

11. FIT THE ASSEMBLED TOP RAIL AND RETAINER ONTO THE LOWER RETAINER MAKING SURE THAT THE WOOD RAIL END CAPS ARE COMPLETELY SEATED ON THE LOWER CRASH RAIL END CAPS.
12. DRILL 3/32" CLEARANCE HOLES THROUGH BOTH THE UPPER AND LOWER RETAINER. WHEN DRILLING APPLY PRESSURE AS INDICATED IN ILLUSTRATION ABOVE IN ORDER TO ACHIEVE PROPER FIT. ATTACH USING THE SUPPLIED FASTENERS.
13. CUT THE ACRYVYN COVERS TO THE PROPER LENGTH. THE COVER LENGTH IS DETERMINED BY MEASURING THE DISTANCE BETWEEN THE INSTALLED END CAPS AND/OR OUTSIDE CORNER ASSEMBLIES.

NOTE: IT IS RECOMMENDED THAT THE ACRYVYN COVERS BY CUT SLIGHTLY LONGER (1/32" UP TO 5'0", 1/16" OVER 5'0") THAN THE MEASURED DISTANCE. THIS ADDITIONAL LENGTH WILL PROVIDE FOR A TIGHTER COVER-TO-END CAP FIT.

14. SNAP THE ACRYVYN COVER ONTO THE LOWER PORTION OF THE RETAINER.
15. DRILL 3/32" PILOT HOLE FOR SUPPLIED FASTENER. ATTACH THE WOOD END CAP TO THE CRASH RAIL END CAP USING THE SUPPLIED SCREW. SEE ILLUSTRATION TO RIGHT.

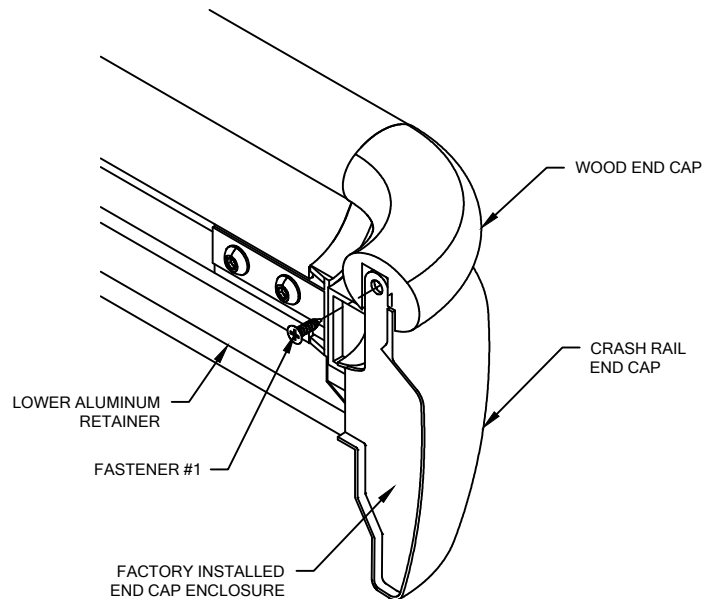

HRBW-20CMN HANDRAIL

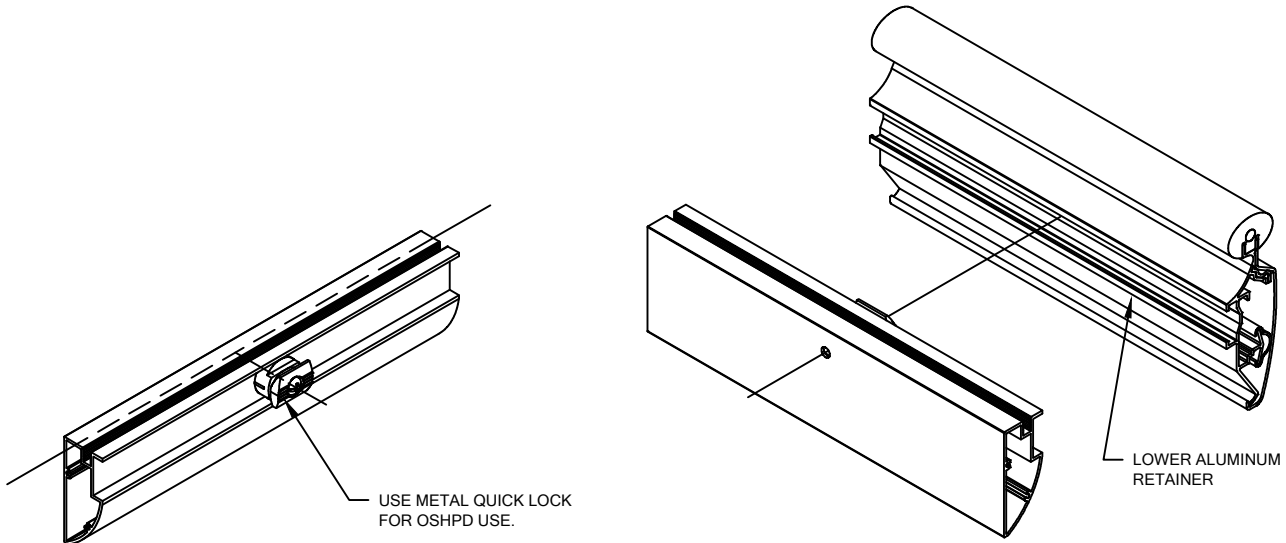

ILLUSTRATION 4

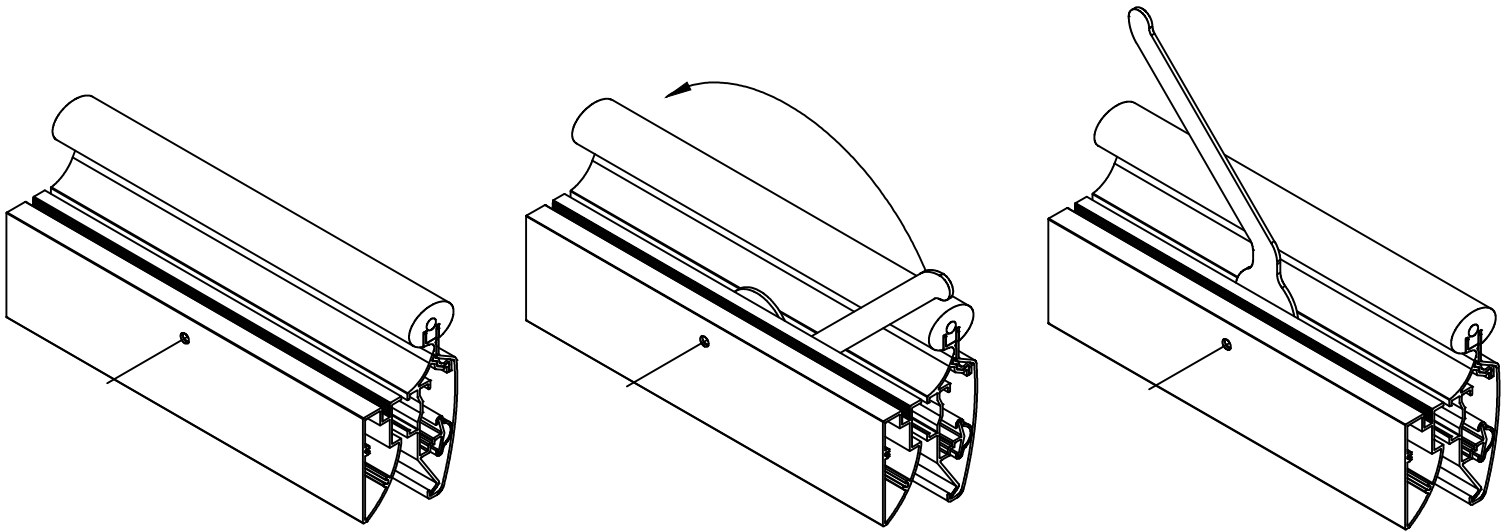

ILLUSTRATION 5

ILLUSTRATION 6

ILLUSTRATION 7

16. REST THE RETAINER ON THE BRACKET ASSEMBLIES. USING THE WRENCH PROVIDED, TWIST EACH LOCK 90° TO SECURE THE MOUNTING BRACKET INTO PLACE. SEE ILLUSTRATIONS ABOVE.

17. FOR OSHPD REQUIREMENTS USE METAL QUICK LOCKS WITH BRACKETS.

HRBW-20CMN HANDRAIL

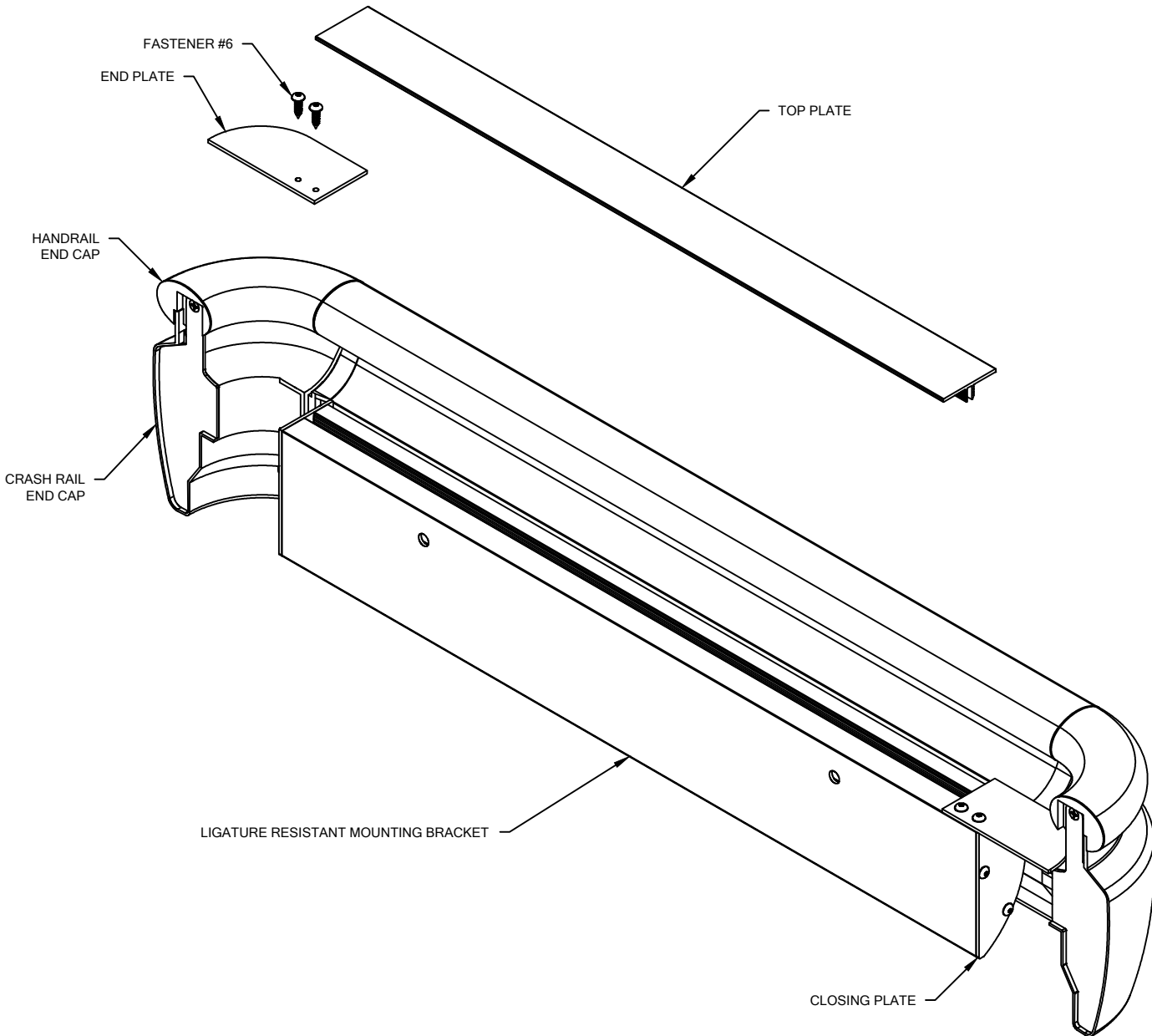

ILLUSTRATION 8

18. USING THE END PLATE/OUTSIDE CORNER PLATE AS A TEMPLATE, MARK THE HOLE LOCATIONS AND DRILL 5/32" PILOT HOLES. INSTALL THE END PLATE WITH TWO (2) #6 X 1/2" TAMPER-RESISTANT SHEET METAL SCREWS (FOUR (4) PER OUTSIDE CORNER PLATE).
19. CUT THE CONTINUOUS TOP PLATE TO THE PROPER LENGTH BY MEASURING THE DISTANCE BETWEEN THE INSTALLED END PLATES AND/OR OUTSIDE CORNER PLATE.
20. INSTALL THE CONTINUOUS TOP PLATE ONTO THE LIGATURE RESISTANT BRACKET BETWEEN THE INSTALLED END PLATES AND/OR OUTSIDE CORNER PLATE.
21. PLACE A WOOD BLOCK ON TOP OF THE CONTINUOUS TOP PLATE. WHILE HOLDING THE CONTINUOUS TOP PLATE SOMEWHAT LEVEL, USE A RUBBER Mallet TO STRIKE THE WOOD BLOCK. (NOTE: DO NOT HAMMER DIRECTLY ONTO THE CONTINUOUS TOP PLATE AS THIS MAY CAUSE DAMAGE TO THE CONTINUOUS TOP PLATE.)
22. WORK DOWN ALONG THE LENGTH OF THE CONTINUOUS TOP PLATE DRIVING THE TOP PLATE APPROXIMATELY HALF ONTO THE LIGATURE RESISTANT BRACKET. RETURN AND DRIVE THE CONTINUOUS TOP PLATE THE REMAINDER OF THE WAY IN UNTIL THE TOP PLATE IS SEATED FLUSH WITH THE END PLATES AND/OR OUTSIDE CORNER PLATE.

3/27/15