

CONTRACTOR NOTES:

1. ALL DIMENSIONS MUST BE FIELD VERIFIED TO A 1/16" TOLERANCE.
2. DIMENSIONS TO BE OBTAINED AT THE ELEVATION OF MATERIAL LOCATION. ALSO, MOUNTING CONDITION TO BE VERIFIED. FABRICATION CANNOT BEGIN WITHOUT THIS INFO.
3. SOME DIMENSIONS SMALLER THAN 16" MAY BE TOO SMALL TO FABRICATE.

NOTES:

1. ALL RAIL TO BE SUPPLIED PREFABRICATED TO REQUIRED LENGTH. ALL CORNERS AND END CAPS TO BE FACTORY FORMED TO SUIT FIELD CONDITIONS.
2. ALL UNITS TO BE PRE-DRILLED FOR ATTACH. HOLE SPACING TO BE DETERMINED BY UNIT LENGTH, SPACING NOT TO EXCEED 32" ON CENTER.
3. ALL MOUNTING HARDWARE TO BE SUPPLIED FOR FIELD ASSEMBLY AND INSTALLATION.
4. MATERIAL:
CS ECR-32A CRASH RAIL SHALL BE MANUFACTURED FROM A 4" WIDE X 1/4" THICK ALUMINUM EXTRUSION, #4 SATIN FINISH DESIGNED FOR ELASTIC DEFORMATION UNDER IMPACT WITHOUT DAMAGING THE WALL TO WHICH IT HAS BEEN MOUNTED.
5. FINISH:
THE ECR-32A CRASH RAIL SHALL BE FURNISHED WITH A 120 GRIT MECHANICAL & A 204RL1 CLEAR ANODIZE FINISH

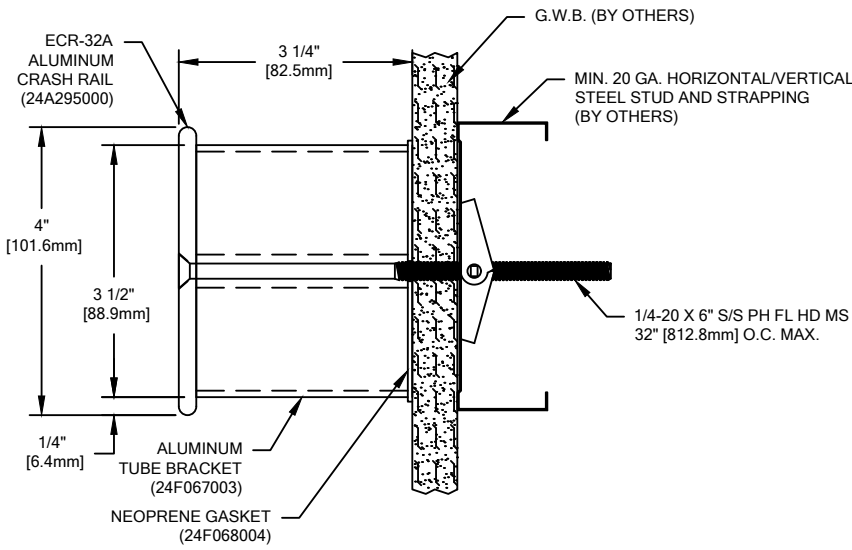

**ECR-32A
"TUBE" BRACKET**

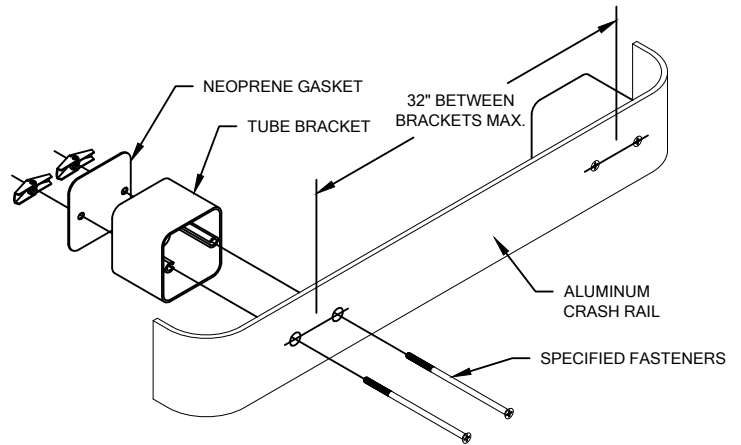

WALL CONDITION	SPECIFIED FASTENER	DRILL DIAMETERS		CS PART NUMBER
		WALL	RETAINER	
STEEL STUD/GYPSUM WALL	1/4-20 X 6" S/S PHILLIPS FLAT HEAD MS 1/4-20 TOGGLE	3/4"	N/A	90H307002 90H019004
CONCRETE/CONC. BLOCK	1/4-20 X 5" S/S PHILLIPS FLAT HEAD MS 1/4-20 X 1 1/4" 4-WAY LEAD SHIELD	1/2"	N/A	90H308002 90H020004
WOOD STUD/GYPSUM WALL	#14 X 6" PHILLIPS FLAT HEAD WOOD SCREW	3/16"	N/A	90H524002

 <p>Hughesville, PA 800.233.8493 570.546.5941 Mississauga, ON 888.895.8955 905.274.3611 www.c-sgroup.com</p> <p>© Copyright 2017 Construction Specialties, Inc.</p>	PROJECT:	REVISION:
	JOB NO.:	F&F:
	CUSTOMER:	
	REP:	DATE:
	DRAWN BY:	SHEET NO: