

## AW-CR CRASH RAIL

### PLEASE READ

PLEASE READ THESE INSTRUCTIONS THOROUGHLY PRIOR TO BEGINNING THE AW-CR CRASH RAIL INSTALLATION!

THIS INSTRUCTION SHEET IS INTENDED TO PROVIDE A SPECIFIC GUIDE TO FOLLOW FOR THE INSTALLATION OF THIS AW-CR CRASH RAIL. CONTAINED WITHIN IS THE TECHNICAL INFORMATION AND INSTALLATION TECHNIQUES REQUIRED TO COMPLETE AN EFFICIENT, NEAT AND LONG-LASTING INSTALLATION.

INSPECT ALL MATERIALS FOR DAMAGE OR MISSING PARTS. IF YOU DISCOVER DAMAGED OR MISSING MATERIALS, IN THE USA PLEASE NOTIFY THE FACTORY AT (800) 233-8493, AND IN CANADA (888) 895-8955 FOR CUSTOMER SERVICE.

AW-CR CRASH RAIL MUST BE INSTALLED IN ACCORDANCE WITH THESE INSTRUCTIONS! FAILURE TO FOLLOW THESE INSTRUCTIONS MAY VOID ANY PRODUCT WARRANTIES AND RESULT IN AN UNSUCCESSFUL INSTALLATION. FOR SPECIFIC QUESTIONS REGARDING THE INSTALLATION OF THIS AW-CR CRASH RAIL PLEASE CALL THE FACTORY IN THE USA AT (800) 233-8493 OR EMAIL [IWPTECHSUPPORT@C-SGROUP.COM](mailto:IWPTECHSUPPORT@C-SGROUP.COM). IN CANADA CALL (888) 895-8955.

### IMPORTANT NOTES

1. DUE TO THE NATURE OF WOOD, COMPONENT COLORS MAY VARY. SORT WOOD HEIGHT COMPONENTS AND MATCH PARTS BY COLOR.
2. ALL LINEAR MATERIAL TO BE SUPPLIED IN STOCK LENGTHS. WOOD IN 7'-0" TO 12'-0" VARIABLE. THIS MATERIAL IS TO BE FIELD CUT USING QUALITY EQUIPMENT TO INSURE THAT ALL CUTS ARE SQUARE. WHEN CUTTING MATERIAL SECTIONS, CS RECOMMENDS USING AN 80-100 TOOTH CARBIDE TIPPED SAW BLADE OR EQUIVALENT, TO MINIMIZE CHIPPING AND MAINTAIN JOINT ALIGNMENT.
3. RADIAL MATERIAL MAY BE SUPPLIED FACTORY FORMED OR IN STRAIGHT LENGTHS FOR FIELD FORMING. CONSULT FACTORY FOR OPTIONS.
4. ALL DIMENSIONS ARE TYPICAL.
5. FOR DRYWALL/PLASTER WALL CONSTRUCTION, IT IS RECOMMENDED FOR FASTENERS TO BE ENGAGED INTO METAL/WOOD STUDS TO MAINTAIN MAXIMUM PULLOUT STRENGTH. IF DURING INSTALLATION YOU ENCOUNTER SPECIAL WALL CONDITIONS THAT DO NOT ALLOW FOR DIRECT ATTACHMENT TO THE STUDS PLEASE CONSULT THE LOCAL AUTHORITY HAVING JURISDICTION.
6. AF-6 PLASTIC ANCHORS SHOULD SEAT FLUSH WITH GYPSUM WALL.
7. INSTALL LONGEST RUN OF CRASH RAIL FIRST.
8. CRASH RAIL SPLICE SHOULD NOT EXCEED 4" [101.6mm] DISTANCE FROM A WALL FASTENER.
9. MATERIAL MUST REACH 65°F MIN. TO 75° MAX. 24 HOURS PRIOR TO INSTALLATION. THIS IS ESSENTIAL TO MINIMIZE EXPANSION AND CONTRACTION.
10. END CAPS AND INSIDE/OUTSIDE CORNERS ARE TO BE FIELD MITERED.
11. SPLICES ARE TO BE CUT AT A 45-DEGREE ANGLE AS SHOWN IN THESE INSTRUCTIONS.
12. TANGENT POINTS ON FACTORY FORMED RADIAL MATERIAL WILL BE MARKED APPROXIMATELY AND SHOULD BE CUT TO SUIT FIELD CONDITIONS.
13. THIS CRASH RAIL REQUIRES A MINIMUM LENGTH OF 4 1/4" [107.95mm].
14. FOR MORE INFORMATION ON AW-CR CRASH RAIL SEE OUR WEBSITE AT [www.c-sgroup.com](http://www.c-sgroup.com).

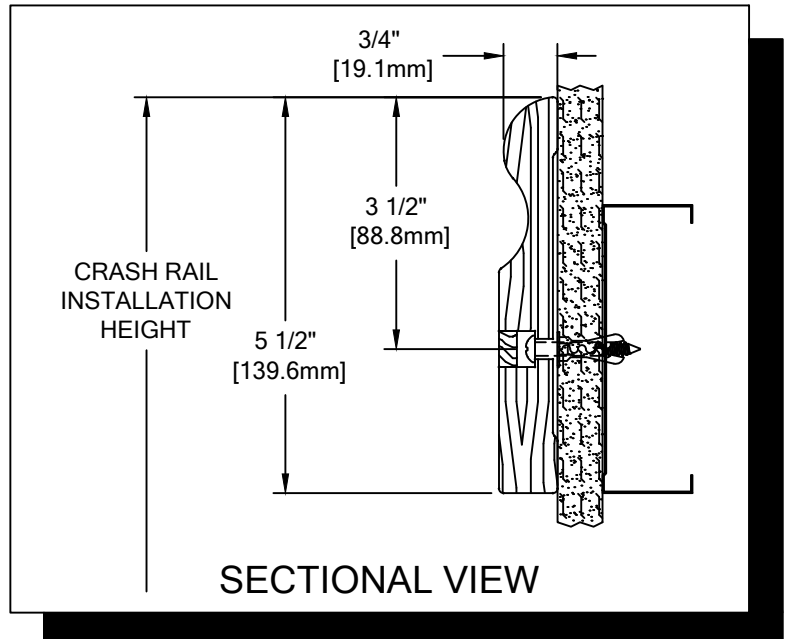

**AW-CR CRASH RAIL**

COMPONENTS & WALL FASTENERS



AW-CR WOOD CRASH RAIL  
(24W530xxx)



AW-CRVB WOOD CRASH RAIL  
(24W525xxx)



OPTIONAL FEATURE INSERT  
(24V012xxx)



FACE PLUGS  
(24W502xxx)

WALL CONDITION	SPECIFIED FASTENER	DRILL DIAMETERS		CS PART NUMBER
		WALL	RETAINER	
STEEL STUD/GYPSUM WALL	#10 X 1 1/2" PHILLIPS PAN HEAD SMS AF-6 PLASTIC ANCHORS	1/4"	N/A	90H189002 90H039004
CONCRETE/CONCRETE BLOCK	#10 X 1 1/2" PHILLIPS PAN HEAD SMS AF-6 PLASTIC ANCHORS	1/4"	N/A	90H189002 90H039004
WOOD STUD/GYPSUM WALL	#9 X 2-1/4" WAFER HD PH DRYWALL SCREW	N/A	N/A	90H421002
20 GA. MIN. STEEL STUD AND 20 GA. MIN. STEEL STRAPPING / GYPSUM WALL CONSTRUCTION REQUIRED (TEK SCREWS)	#6 PHILLIPS PAN HEAD BUGLE HEAD TEK SCREW	N/A	N/A	90H079002

**AW-CR CRASH RAIL**

LAYOUT VIEW

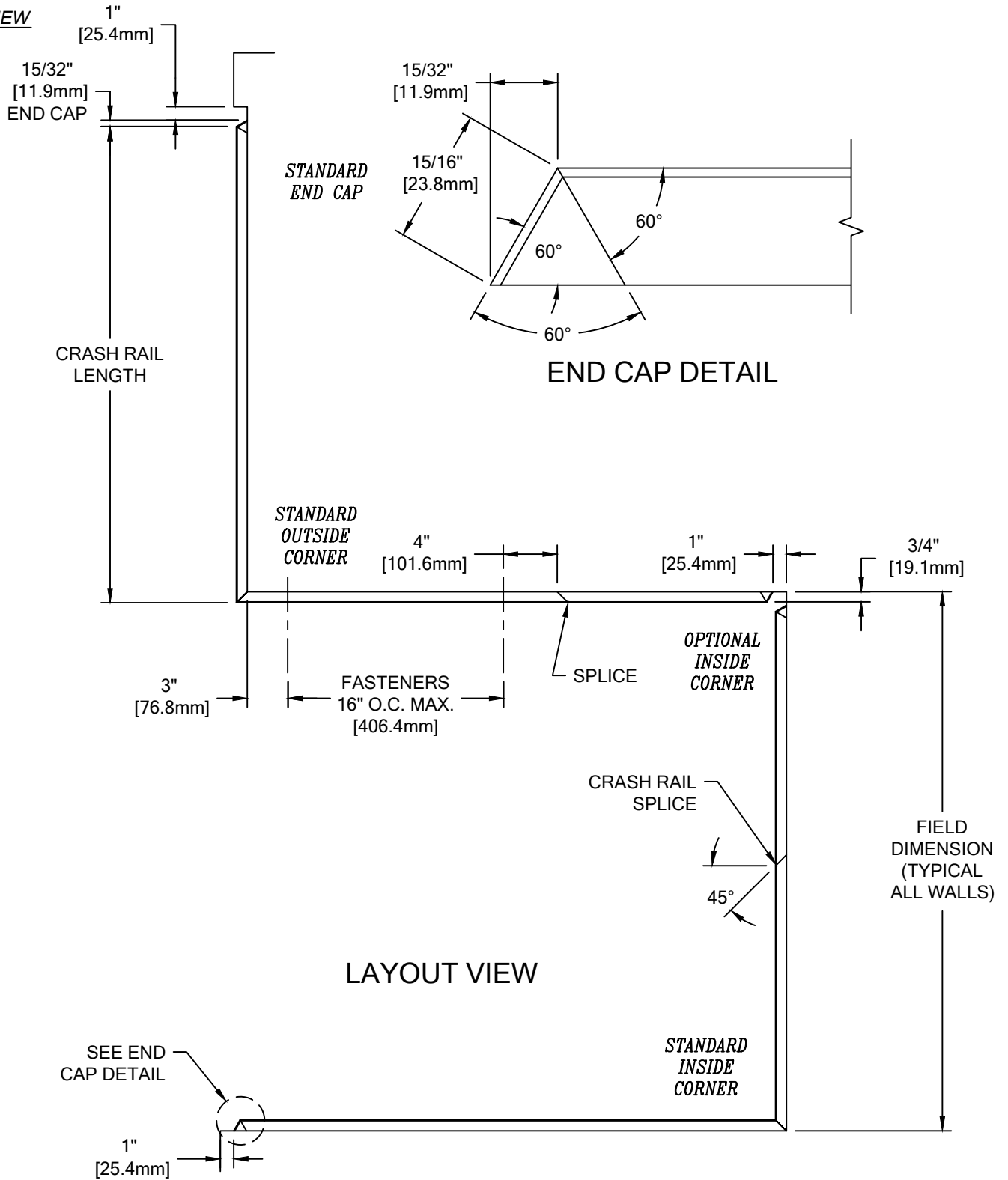

**LAYOUT VIEW**

**AW-CR CRASH RAIL**

TYPICAL ASSEMBLY

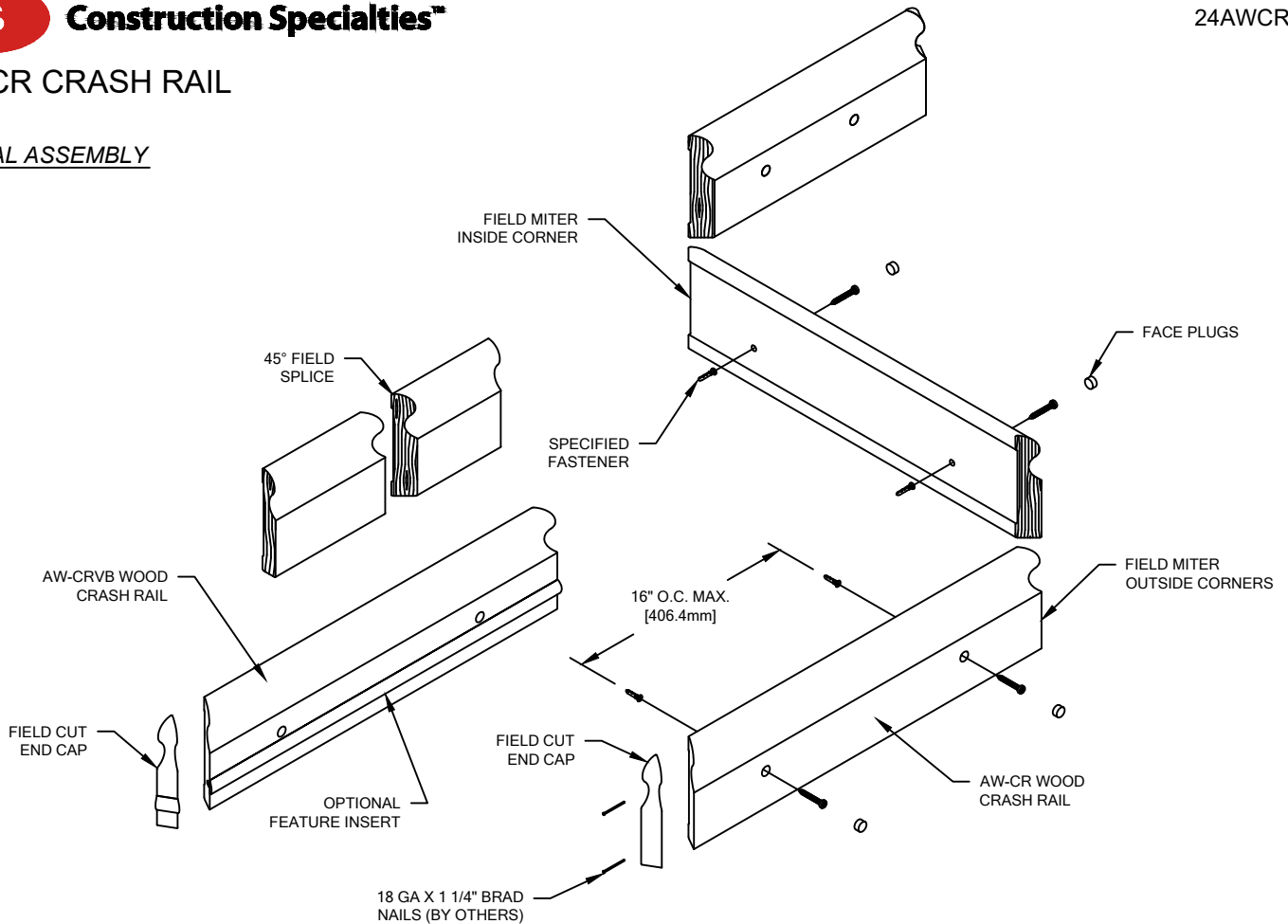

**NOTE:** INSTALLATION OF LINEAL OR RADIAL AW-CR CRASH RAIL SHOULD BE DONE IN ACCORDANCE WITH THE FOLLOWING INSTRUCTIONS.

1. ESTABLISH CRASH RAIL HEIGHT ABOVE FINISH FLOOR. DEDUCT 3 1/2" [88.9mm] AND SNAP A CHALK LINE AT THAT HEIGHT. THIS MARKS THE LOCATION OF THE MOUNTING FASTENERS.
2. CUT WOOD CRASH RAIL TO LENGTH (REFERENCE LAYOUT VIEW). ALL INSIDE AND OUTSIDE CORNERS ARE TO BE FIELD MITERED. ENDS THAT RECEIVE END CAPS ARE TO BE CUT AT A 60-DEGREE ANGLE (SEE END CAP DETAIL ON PAGE 3).

**NOTE:** IT IS RECOMMENDED THAT WOOD CRASH RAIL BE CUT WITH AN 80-100 TOOTH CARBIDE TIPPED SAW BLADE OR EQUIVALENT.

3. DUE TO THE COLOR MATCH, END CAPS ARE TO BE CUT FROM THE SAME CRASH RAIL SECTION. FIELD CUT THE END CAPS WITH 60-DEGREE CUTS ON BOTH ENDS. (SEE END CAP DETAIL ON PAGE 3)
4. ATTACH END CAPS TO THE CRASH RAIL WITH WOOD GLUE (TITEBOND IS RECOMMENDED) AND TWO (2) 18 GA X 1 1/4" BRAD NAILS. CRASH RAILS THAT INTERSECT AT INSIDE/OUTSIDE CORNERS ARE TO BE JOINED IN THE SAME MANNER. WIPE OFF ANY EXCESS GLUE. FILL BRAD NAIL LOCATIONS USING THE PUTTY STICK SUPPLIED IN THE TOUCH UP KIT. EASE MITERED JOINT EDGES BY ADDING A SMALL BEVEL TO ELIMINATE SHARP EDGES. TOUCH UP. SANDED EDGES WITH STAIN MARKER.
5. DRILL 1/2" [12.7mm] COUNTERBORE 1/2" [12.7mm] DEEP WITH 9/64" [3.6mm] CLEARANCE HOLES FOR THE FASTENER 3" [76.2mm] FROM EACH END AND 16" [406.4mm] O.C. MAX. ALONG CRASH RAIL LENGTH.
6. DRILL CLEARANCE HOLES IN WALL SURFACE FOR MOUNTING HARDWARE, USING THE BORED CRASH RAIL AS A TEMPLATE. REFERENCE CHART ON PAGE 2 FOR CORRECT DRILL DIAMETERS.
7. MOUNT THE CRASH RAIL TO THE WALL USING THE APPROPRIATE FASTENERS. INSTALL FACE PLUGS USING WOOD GLUE TO COVER FASTENER LOCATIONS.

**NOTE:** WHEN FIELD FORMING RADIUS CRASH RAIL, BE SURE TO APPLY NEEDED PRESSURE FROM FASTENER TO FASTENER.

8. FOR AW-CRWB ONLY, INSTALL THE FEATURE INSERT BY APPLYING EVEN HAND PRESSURE AND PUSH THE FEATURE INSERT INTO THE CRASH RAIL. FOR END CAPS AND INSIDE/OUTSIDE CORNERS THE FEATURE INSERT WILL NEED MITERED.

**NOTE:** ALL INSIDE/OUTSIDE CORNERS ARE TO BE FIELD MITERED. FOR INSIDE CORNER CONDITIONS A FILE MAY BE USED ON BACKSIDE OF CRASH RAIL TO ACCOMMODATE ANY RADIUS INSTALLED IN DRYWALL.

**NOTE:** SPLICES SHOULD BE CUT AT A 45-DEGREE ANGLE, AS ILLUSTRATED. STAIN MARKER SHOULD BE APPLIED TO THE CUT SURFACES OF THE CRASH RAIL BEFORE BEING MOUNTED ON THE WALL.