

**P-OAMN HANDRAIL**  
WITH INTERNATIONAL OFFSET

PLEASE READ

PLEASE READ THESE INSTRUCTIONS THOROUGHLY PRIOR TO BEGINNING THE P-OAMN HANDRAIL INSTALLATION!

THIS INSTRUCTION SHEET IS INTENDED TO PROVIDE A SPECIFIC GUIDE TO FOLLOW FOR THE INSTALLATION OF THIS P-OAMN HANDRAIL. CONTAINED WITHIN IS THE TECHNICAL INFORMATION AND INSTALLATION TECHNIQUES REQUIRED TO COMPLETE AN EFFICIENT, NEAT AND LONG-LASTING INSTALLATION.

INSPECT ALL MATERIALS FOR DAMAGE OR MISSING PARTS. IF YOU DISCOVER DAMAGED OR MISSING MATERIALS, IN THE USA PLEASE NOTIFY THE FACTORY AT (800) 233-8493, AND IN CANADA (888) 895-8955 FOR CUSTOMER SERVICE.

P-OAMN HANDRAIL MUST BE INSTALLED IN ACCORDANCE WITH THESE INSTRUCTIONS! FAILURE TO FOLLOW THESE INSTRUCTIONS MAY VOID ANY PRODUCT WARRANTIES AND RESULT IN AN UNSUCCESSFUL INSTALLATION. FOR SPECIFIC QUESTIONS REGARDING THE INSTALLATION OF THIS P-OAMN HANDRAIL PLEASE CALL THE FACTORY IN THE USA AT (800) 233-8493 OR EMAIL [IWPTECHSUPPORT@C-SGROUP.COM](mailto:IWPTECHSUPPORT@C-SGROUP.COM). IN CANADA CALL (888) 895-8955 .

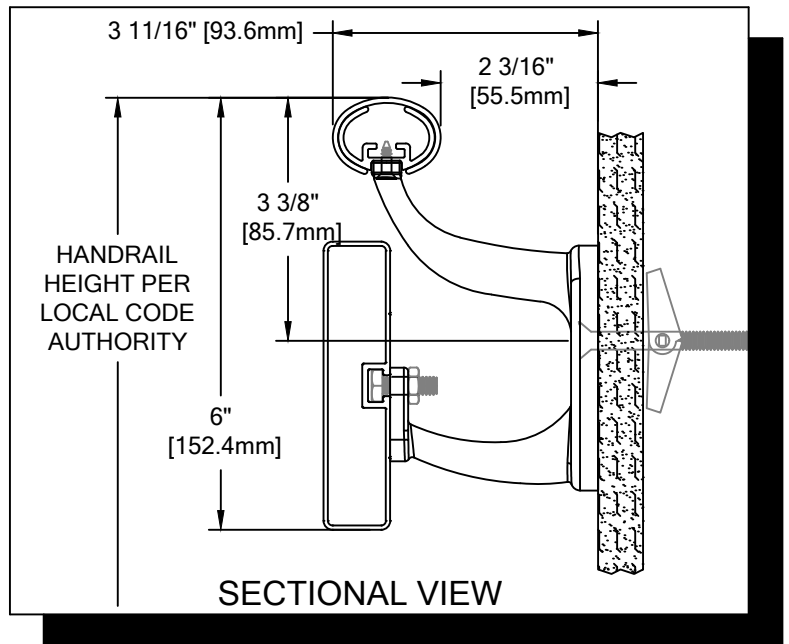

IMPORTANT NOTES

1. ALL LINEAL MATERIAL TO BE SUPPLIED IN STOCK LENGTHS. POWDER COATED CRASH RAIL IN 12'-0", AND ALUMINUM AND ACROVYN IN LENGTHS UP TO 20'-0". THIS MATERIAL IS TO BE FIELD CUT USING QUALITY EQUIPMENT TO INSURE THAT ALL CUTS ARE SQUARE. WHEN CUTTING MATERIAL SECTIONS, CS RECOMMENDS USING AN 80-100 TOOTH CARBIDE TIPPED SAW BLADE OR EQUIVALENT, TO MINIMIZE CHIPPING AND MAINTAIN JOINT ALIGNMENT.
2. ALL DIMENSIONS ARE TYPICAL.
3. FOR DRYWALL/PLASTER WALL CONSTRUCTION, IT IS RECOMMENDED FOR FASTENERS TO BE ENGAGED INTO METAL/WOOD STUDS TO MAINTAIN MAXIMUM PULLOUT STRENGTH. IF DURING INSTALLATION YOU ENCOUNTER SPECIAL WALL CONDITIONS THAT DO NOT ALLOW FOR DIRECT ATTACHMENT TO THE STUDS PLEASE CONSULT THE LOCAL AUTHORITY HAVING JURISDICTION.
4. INSTALL OUTSIDE CORNERS FIRST.
5. INSTALL LONGEST RUN OF HANDRAIL FIRST.
6. ALUMINUM RETAINER SPLICE SHOULD NOT EXCEED 3" [76.2mm] DISTANCE FROM A BRACKET.
7. THE DISTANCE BETWEEN AN ACROVYN SPLICE JOINT AND AN ALUMINUM RETAINER SPLICE JOINT SHOULD NOT BE LESS THAN 12" [304.8mm].
8. MATERIAL MUST REACH 65°F MIN. TO 75° MAX. 24 HOURS PRIOR TO INSTALLATION. THIS IS ESSENTIAL TO MINIMIZE EXPANSION AND CONTRACTION.
9. MAY REQUIRE USE OF FIRE PUTTY WHEN INSTALLED ON FIRE WALL WITH TOGGLE BOLTS. REFERENCE INSTRUCTIONS 24FIREPUTTY FOR FIRE PUTTY INSTALLATION.
10. THIS HANDRAIL REQUIRES A MINIMUM OF 2 MOUNTING BRACKETS PER UNIT. THE MINIMUM END CAP-TO-END CAP HANDRAIL LENGTH IS 13 3/8" [339.7mm].
11. FOR MORE INFORMATION ON P-OAMN HANDRAIL SEE OUR WEBSITE AT [www.c-sgroup.com](http://www.c-sgroup.com).

**P-OAMN HANDRAIL  
WITH INTERNATIONAL OFFSET**

COMPONENTS & WALL FASTENERS



ACROVYN HANDRAIL COVER  
(24U800xxx)  
ACROVYN CHAMELEON COVER  
(24U934xxx)



ALUMINUM HANDRAIL  
RETAINER  
(24A221000)



POWDER COATED  
CRASH RAIL  
(24A223xxx)

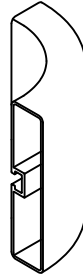

POWDER COATED  
CRASH RAIL ENDCAP/  
OUTSIDE CORNER  
(24M067xxx)

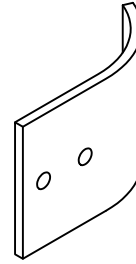

CRASH RAIL ENDCAP  
MOUNTING PLATE  
(90H181010)



FASTENER #1  
1/4" LOCK WASHER  
(90H006003)

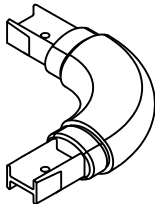

HANDRAIL OUTSIDE  
CORNER ASSEMBLY

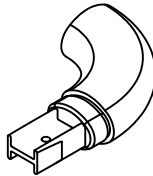

HANDRAIL END CAP  
(24I841xxx-LH)  
(24I840xxx-RH, SHOWN)  
CHAMELEON END CAP  
(24I991xxx, LH)  
(24I992xxx, RH)

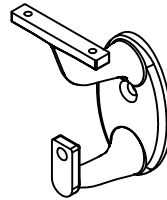

DOUBLE POST FLAT  
PLATFORM BRACKET  
(24M994XXX)  
OPTIONAL STAINLESS STEEL  
MOUNTING BRACKET  
(24S171000)

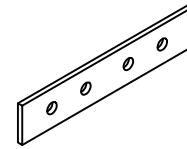

CRASH RAIL  
RETAINER SPLICE BAR  
(24I976000)



FASTENER #2  
1/4-20 HEX NUT  
(90H010001)

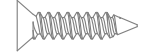

FASTENER #3  
#6 X 5/8" S/S PHILLIPS  
FLAT HEAD SMS  
(90H231004)

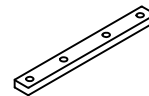

HANDRAIL  
SPLICE PLATE  
(90H150010)

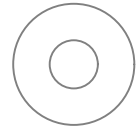

FASTENER #4  
1/4" FLAT WASHER  
(90H007003)

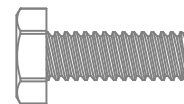

FASTENER #5  
1/4-20 X 3/4" S/S  
HEX HEAD  
MACHINE SCREW  
(90H008006)

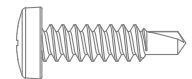

FASTENER #6  
#10 X 3/4" S/S PHILLIPS  
PANHEAD TEK SCREW  
(90H739006)

WALL CONDITION	SPECIFIED FASTENER	DRILL DIAMETERS		CS PART NUMBER
		WALL	RETAINER	
STEEL STUD/GYPSUM WALL	1/4-20 X 3" S/S FLAT HEAD BOLT WITH TOGGLE	3/4"	N/A	90H184002
CONCRETE/CONCRETE BLOCK	1/4" X 1 3/4" S/S FLAT HEAD MASONRY ANCHOR	3/16"	N/A	90H390000
WOOD STUD/GYPSUM WALL	#14 X 3" S/S PHILLIPS FLAT HEAD WOOD SCREW	7/32"	N/A	90H538004

**P-OAMN HANDRAIL**  
WITH INTERNATIONAL OFFSET

LAYOUT VIEW

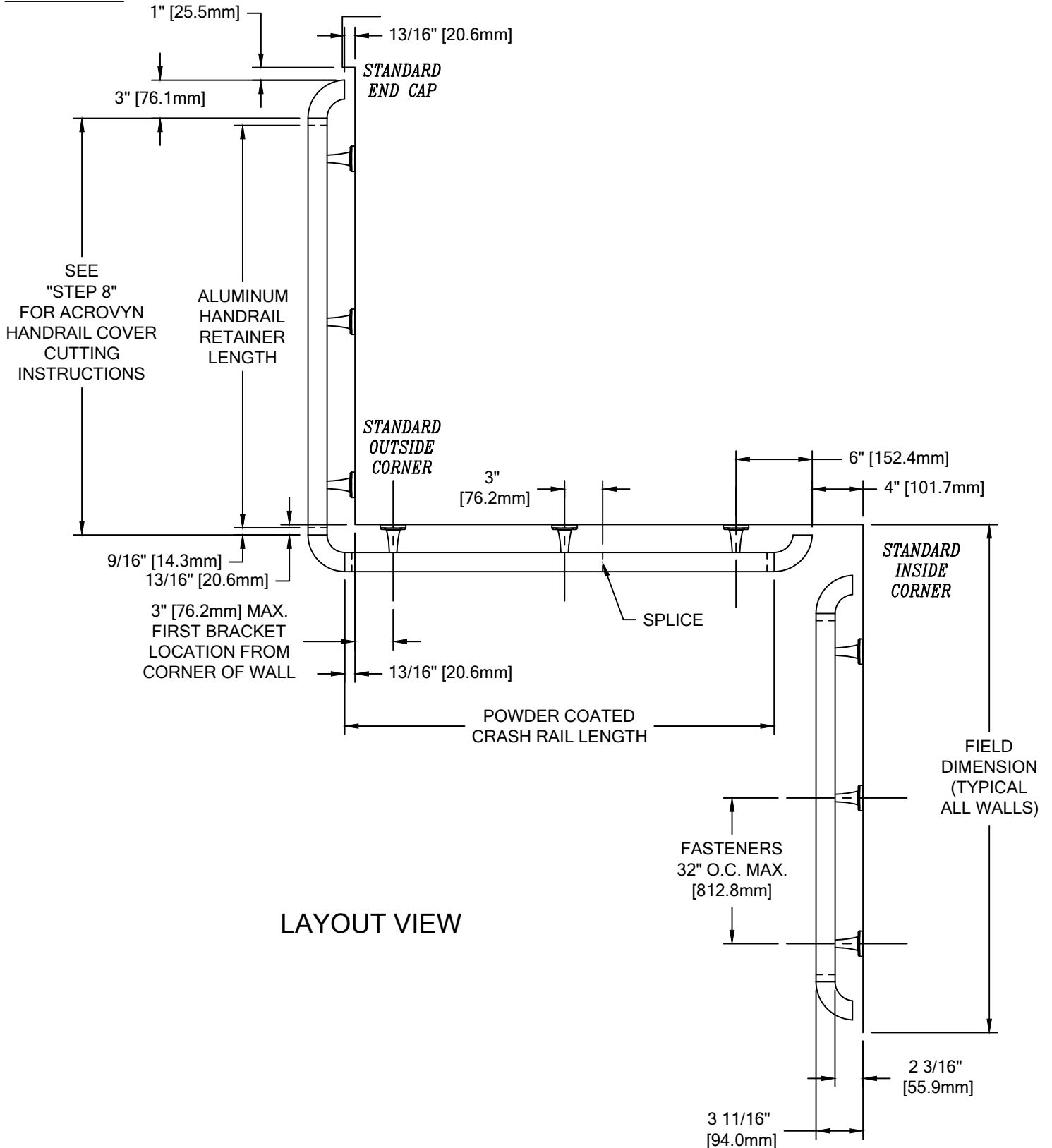

LAYOUT VIEW

**P-OAMN HANDRAIL  
WITH INTERNATIONAL OFFSET**

TYPICAL ASSEMBLY

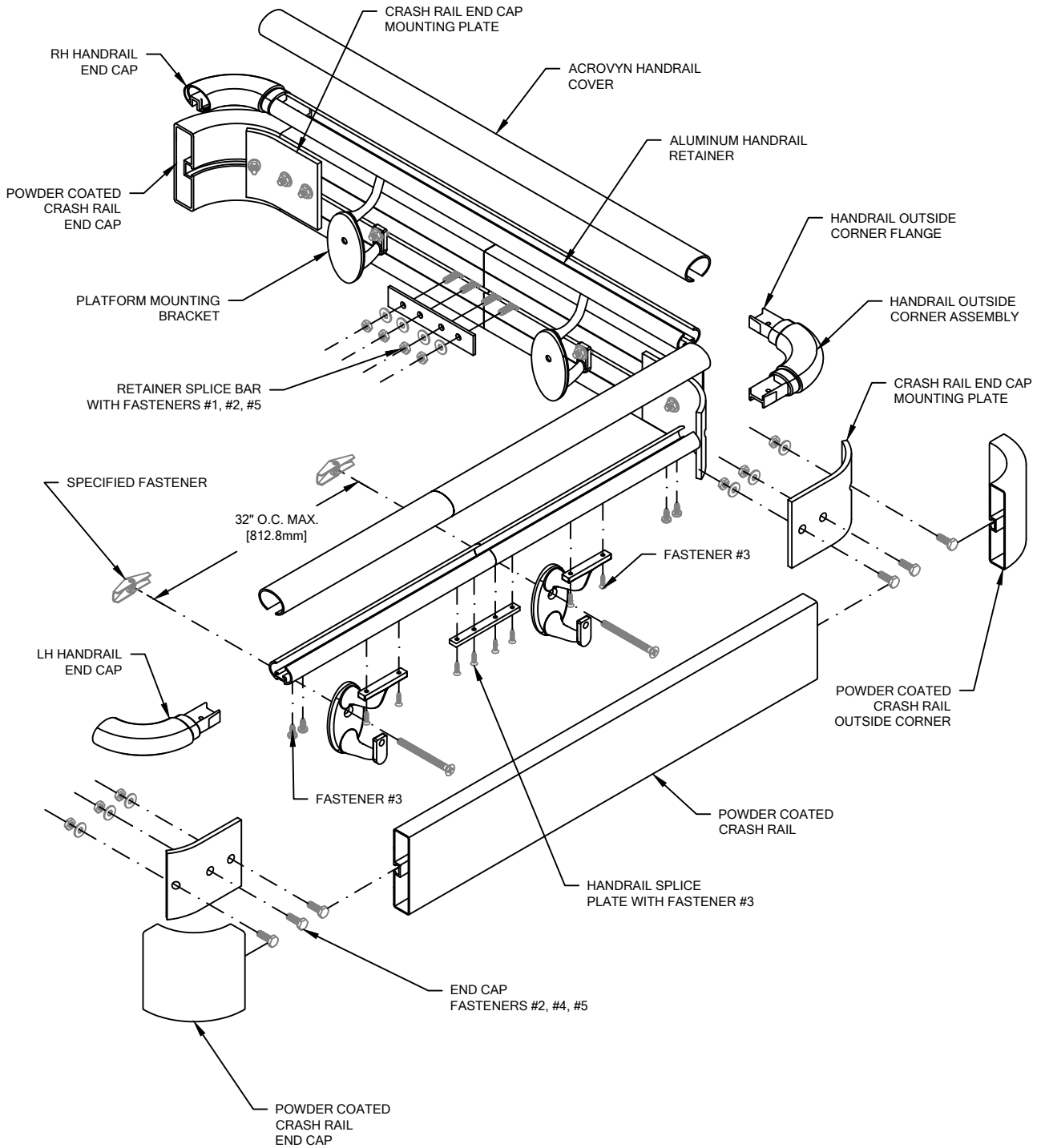

**P-OAMN HANDRAIL  
WITH INTERNATIONAL OFFSET**

TYPICAL HANDRAIL ASSEMBLY

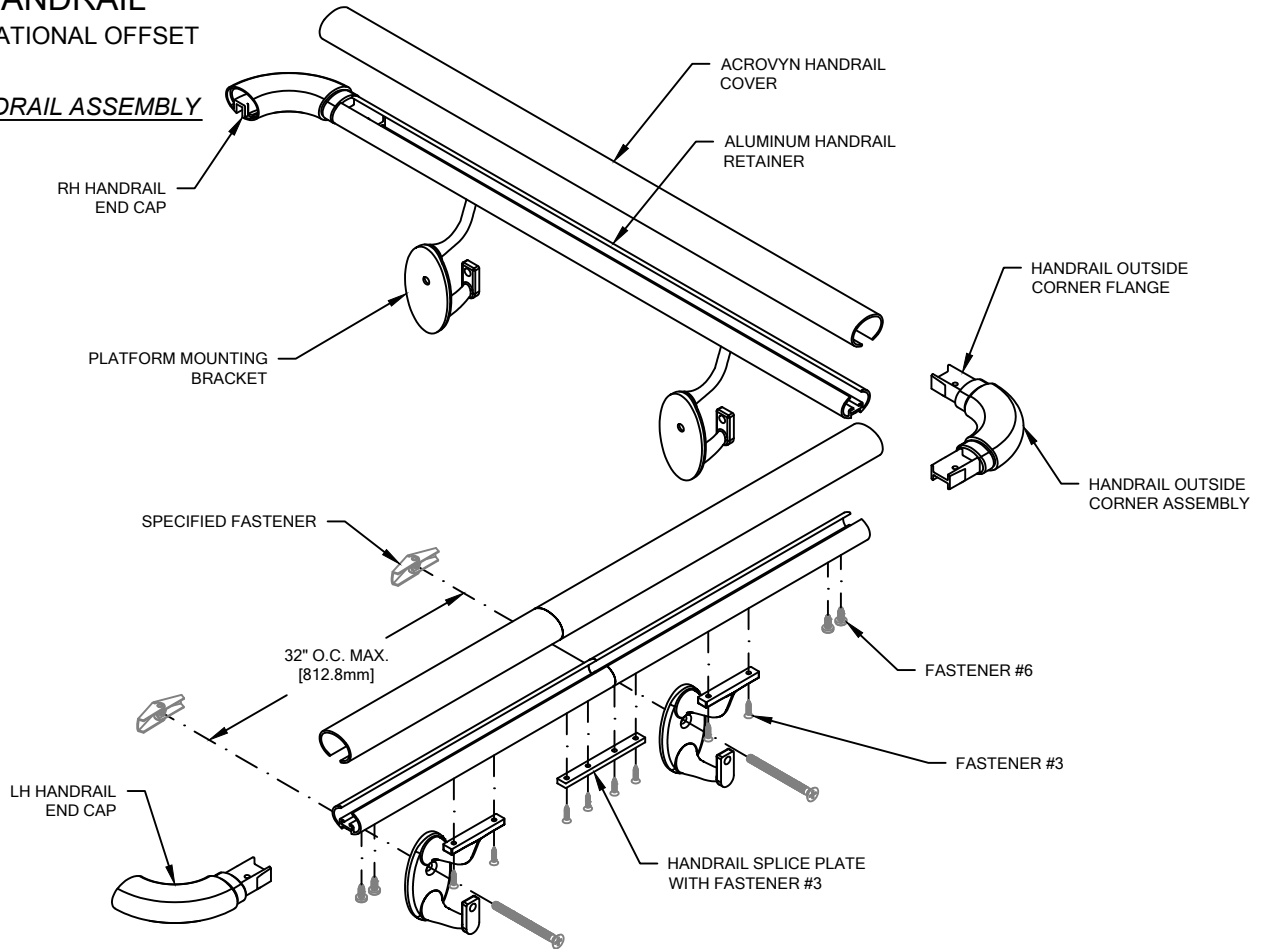

1. USING "LOCAL CODE" REQUIREMENTS, ESTABLISH HANDRAIL HEIGHT ABOVE FINISH FLOOR. DEDUCT 3 3/8" [85.7mm] AND SNAP A CHALK LINE AT THAT HEIGHT. THIS MARKS THE LOCATION OF THE HOLE FOR THE MOUNTING BRACKET FASTENERS.
2. DRILL CLEARANCE HOLES IN WALL SURFACE FOR MOUNTING HARDWARE. REFERENCE CHART ON PAGE 2 FOR CORRECT DRILL DIAMETERS.
3. INSTALL MOUNTING BRACKETS USING APPROPRIATE FASTENERS. USE A LEVEL TO ENSURE THAT THE BRACKETS ARE LEVEL.

NOTE: SEE LAYOUT VIEW TO AID IN MOUNTING BRACKET LOCATION.

4. CUT THE CONTINUOUS ALUMINUM RETAINER TO LENGTH USING THE REQUIRED DEDUCTIONS (SEE LAYOUT VIEW).

NOTE: IT IS RECOMMENDED THAT THE ACROVYN COVER AND ALUMINUM RETAINER BE CUT WITH AN 80-100 TOOTH CARBIDE TIPPED SAW BLADE OR EQUIVALENT.

5. ATTACH END CAPS AND OUTSIDE CORNERS:
  - INSERT THE END CAP INTO THE RETAINER.
  - DRILL 1/8" DIAMETER PILOT HOLES THROUGH THE BOTTOM OF THE RETAINER AND END CAP, 7/8" [22.2mm] AND 1 9/16" [39.7mm] FROM THE END OF THE RETAINER.
  - REMOVE END CAP AND DRILL 11/64" CLEARANCE HOLES FOR #10 X 3/4" PHILLIPS PANHEAD TEK SCREW.
  - ATTACH END CAP TO RETAINER WITH THE ABOVE MENTIONED SCREWS, UP THROUGH THE BOTTOM OF THE RETAINER.

NOTE: TO AID IN LOCATING THE END CAPS CORRECTLY, CUT A 4" [101.6mm] SECTION OF COVER FROM SCRAP AND SNAP IT ON THE RETAINER. LOCATE THE CAP SO IT ALIGNS FLUSH WITH TOP AND BOTTOM OF THE COVER.

6. DRILL 1/16" PILOT HOLES INTO THE RETAINER FOR MOUNTING BRACKET ATTACHMENT. MOUNTING BRACKETS ARE TO BE LOCATED 3" [76.2mm] FROM EACH END OF THE RETAINER AND 32" [612.6mm] ON CENTER ALONG LENGTH, AS REQUIRED.
7. FASTEN THE ALUMINUM RETAINER TO THE WALL BRACKETS IN SUCCESSION BY INSERTING TWO #6 X 5/8" PHILLIPS FLAT HEAD SHEET METAL SCREWS THROUGH THE UNDERSIDE OF BRACKET INTO THE RETAINER. CAUTION: OVER-TORQUEING MAY CAUSE THE FASTENERS TO STRIP.
8. CUT THE ACROVYN COVER TO THE PROPER LENGTH. THE COVER LENGTH IS DETERMINED BY MEASURING THE DISTANCE BETWEEN THE INSTALLED END CAPS AND/OR OUTSIDE CORNER ASSEMBLIES.

NOTE: IT IS RECOMMENDED THAT THE ACROVYN COVER BE CUT SLIGHTLY LONGER (1/32" [0.8mm] UP TO 5'-0" [1.5m], 1/16" [1.6mm] OVER 5'-0" [1.5m]) THAN THE MEASURED DISTANCE. THIS ADDITIONAL LENGTH WILL PROVIDE FOR A TIGHTER COVER-TO-END CAP FIT.

9. STARTING AT ONE END, SNAP THE ACROVYN COVER ONTO THE RETAINER ALONG THE LENGTH OF THE HANDRAIL.

NOTE: MANUFACTURER RECOMMENDS ALL PRINTED "PRODUCT IDENTIFICATION" ON THE REAR OF THE ACROVYN PROFILE SHALL BE ORIENTED IN THE SAME DIRECTION DURING INSTALLATION TO ENSURE PROPER ALIGNMENT AT SPLICE BUTT JOINTS.

**P-OAMN HANDRAIL  
WITH INTERNATIONAL OFFSET**

TYPICAL CRASH RAIL ASSEMBLY

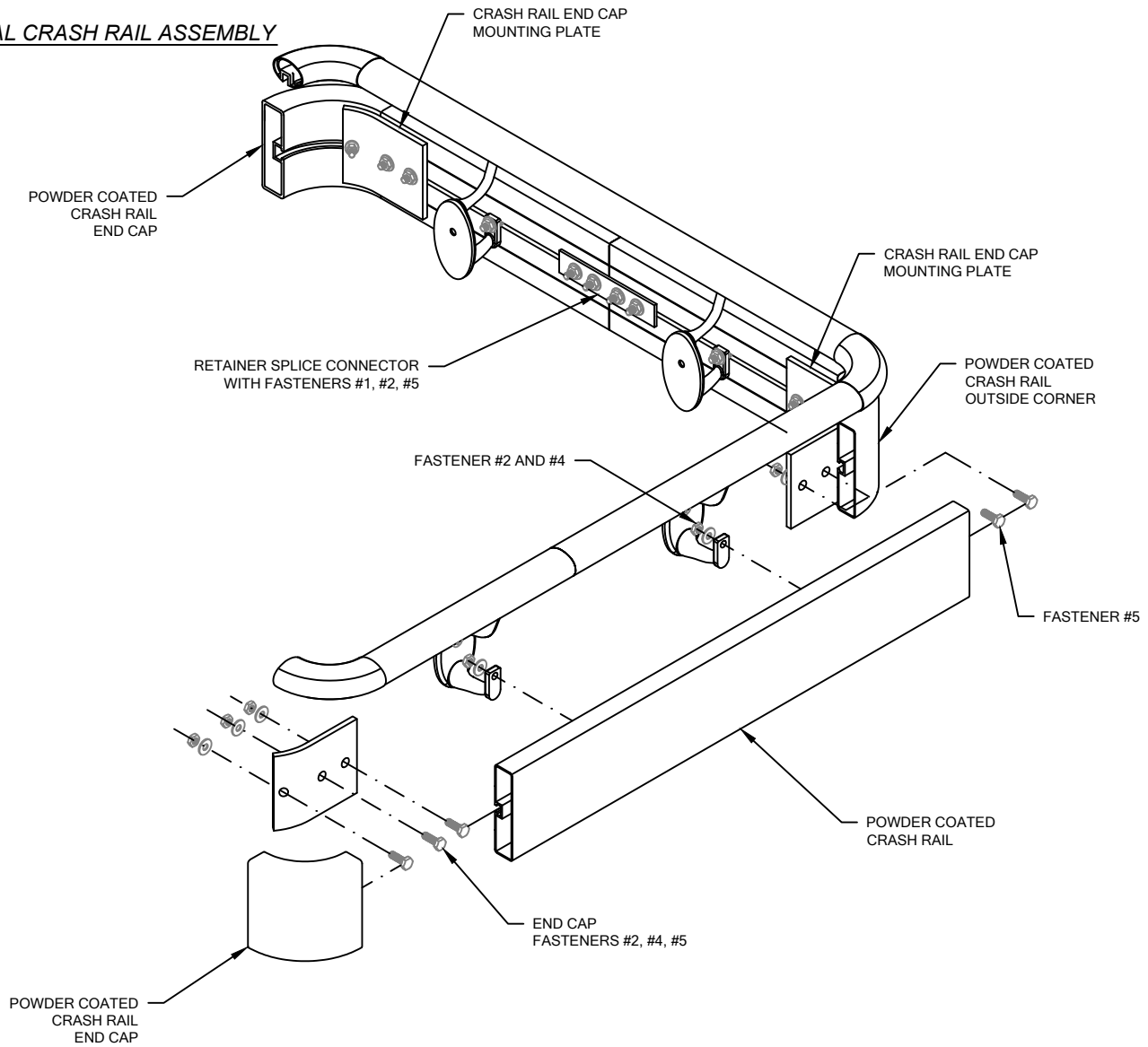

10. CUT THE CONTINUOUS POWDER COATED CRASH RAIL TO LENGTH USING THE REQUIRED DEDUCTIONS (SEE LAYOUT VIEW).

**NOTE:** IT IS RECOMMENDED THAT CONTINUOUS POWDER COATED CRASH RAIL BE CUT WITH AN 80-100 TOOTH CARBIDE TIPPED SAW BLADE OR EQUIVALENT.

11. ATTACH POWDER COATED CRASH RAIL END CAPS AND OUTSIDE CORNERS:
- SLIDE 1/4-20 X 3/4" HEX HEAD BOLTS IN THE RECEIVER SLOT OF THE CRASH RAIL RETAINER FOR ALL WALL BRACKETS.
  - PARTIALLY FASTEN 1/4-20 X 3/4" HEX HEAD BOLTS ONTO MOUNTING PLATE (NOTE THE ORIENTATION IN DRAWING ABOVE).
  - SLIDE HEAD OF BOLTS INTO GROOVES OF THE CRASH RAIL AND END CAP.
  - ALIGN CRASH RAIL WITH END CAP SO THEY ARE FLUSH TOGETHER.
  - SECURELY TIGHTEN ALL FASTENERS.
12. ATTACH POWDER COATED CRASH RAIL TO THE WALL BRACKETS:
- ALIGN HEX HEAD BOLT WITH MOUNTING BRACKETS.
  - INSERT HEX HEAD BOLT INTO THE MOUNTING BRACKET HOLE.
  - PLACE A 1/4" FLAT WASHER AND 1/4-20 HEX NUT ONTO THE HEX HEAD BOLT.
  - TIGHTEN AS REQUIRED.

3/7/18