

COLOR: \_\_\_\_\_  
 HANDRAIL WOOD SPECIES: \_\_\_\_\_  
 HANDRAIL WOOD FINISH: \_\_\_\_\_  
 COLOR TO BE SELECTED FROM ONE OF C/S STANDARD COLORS.

TOTAL L/F REQ'D	LEFT END CAPS	RIGHT END CAPS

**NOTES:**

- THIS MODEL IS FABRICATED CUT-TO-SIZE, THEREFORE FIELD VERIFIED DIMENSIONS ARE REQUIRED.

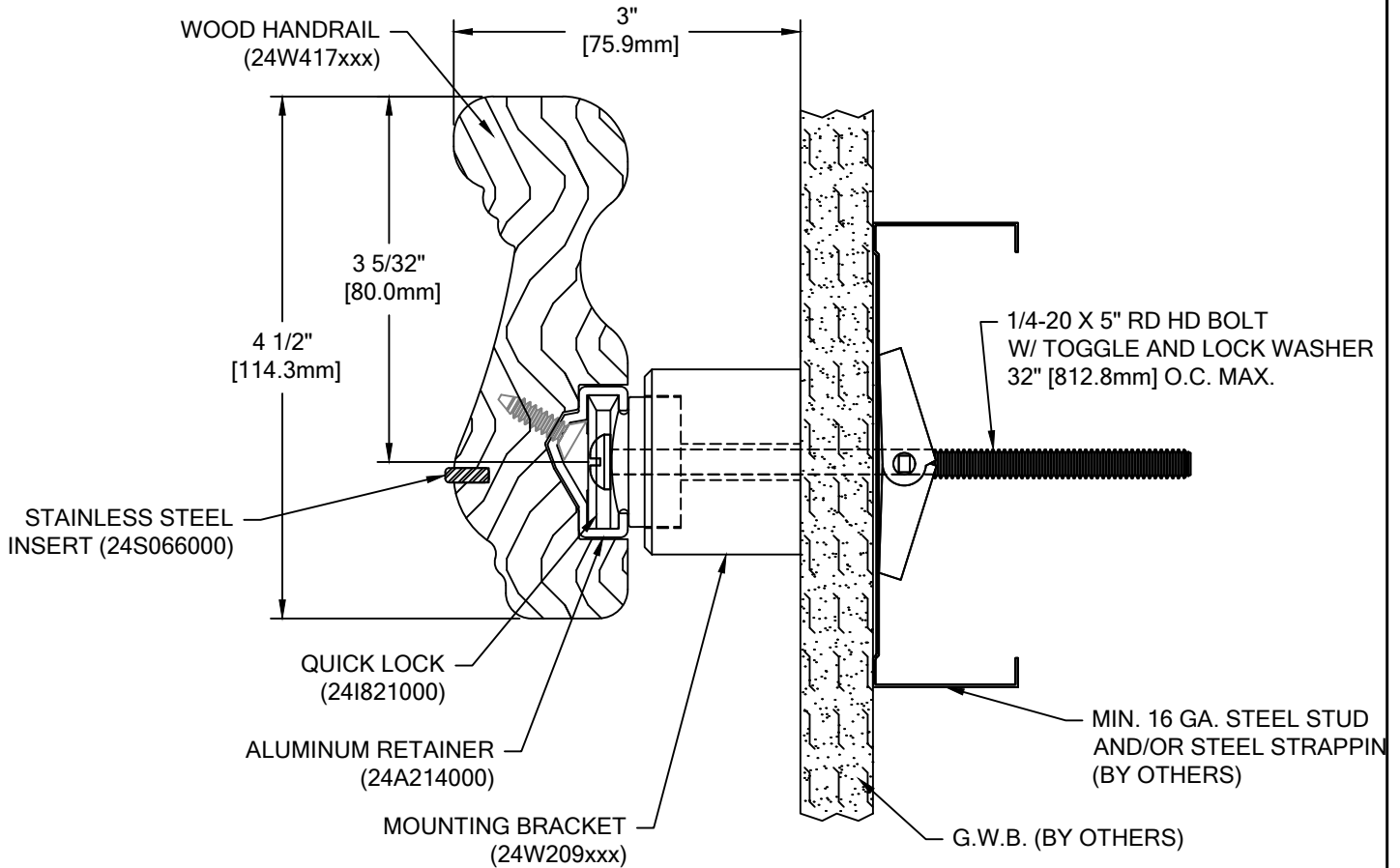

# HRW-45S

WALL CONDITION	SPECIFIED FASTENER	DRILL DIAMETERS		C/S PART NUMBER
		WALL	RETAINER	
STEEL STUD/GYPSUM WALL	1/4-20 X 5" ROUND HEAD BOLT WITH TOGGLE, AND LOCK WASHER	3/4"	N/A	90H049002 90H006003
CONCRETE/CONCRETE BLOCK	#14 X 5" PHILLIPS RD HD ALL-PURPOSE SCREW	3/16"	N/A	90H287002
WOOD STUD/GYPSUM WALL	#14 X 5" PHILLIPS RD HD ALL-PURPOSE SCREW	1/8"	N/A	90H287002
16 GA. MIN. STEEL STUD AND 16 GA. MIN. STEEL STRAPPING / GYPSUM WALL CONSTRUCTION REQUIRED (TEK SCREWS)	#14 X 5" PHILLIPS PAN HEAD #3 SELF DRILLING TEK SCREW ZINC PLATED	N/A	N/A	90H286001



Hughesville, PA | 800.233.8493 | 570.546.5941  
 Mississauga, ON | 888.895.8955 | 905.274.3611  
[www.c-sgroup.com](http://www.c-sgroup.com)

© Copyright 2018 Construction Specialties, Inc.

<b>PROJECT:</b>	<b>REVISION:</b>
<b>JOB NO.:</b>	<b>F&amp;F:</b>
<b>CUSTOMER:</b>	<b>DATE:</b>
<b>REP:</b>	<b>SHEET NO:</b>
<b>DRAWN BY:</b>	