

MODEL "KB" & "KBW" 400-600 INSTALLATION INSTRUCTIONS

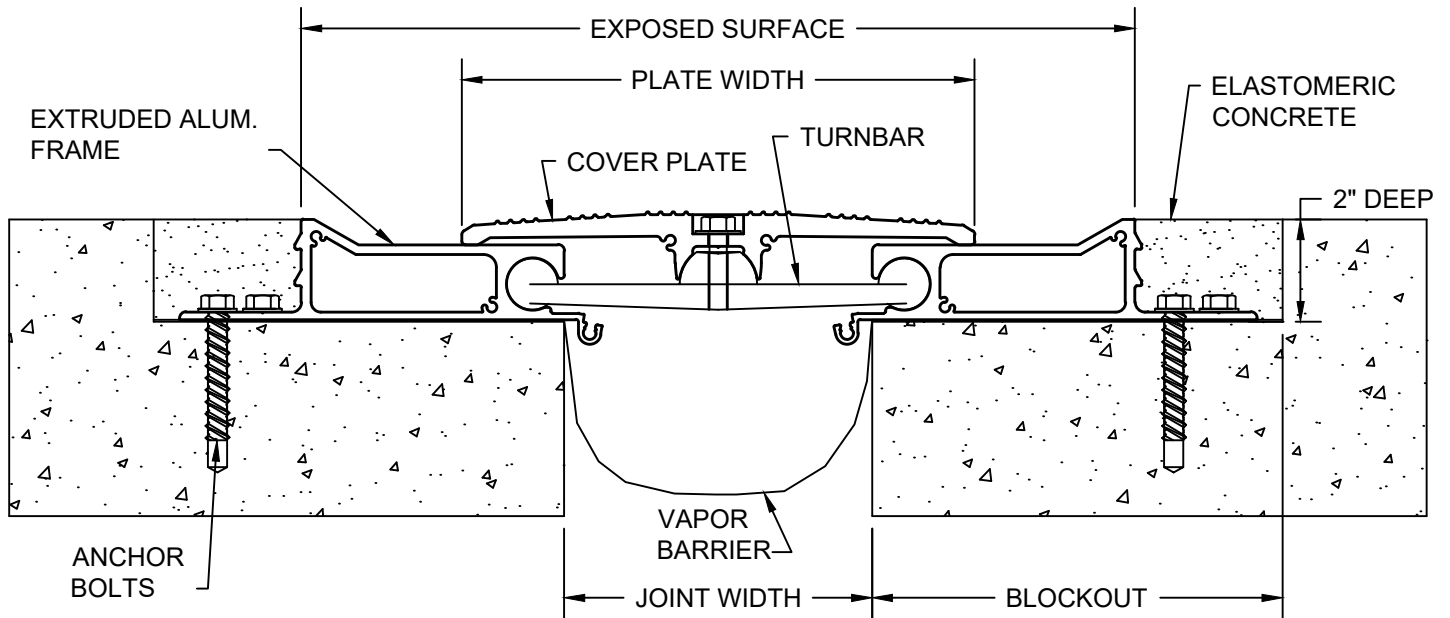

IMPORTANT INFORMATION

Prior to the commencement of Installation, all materials **MUST** be inspected for Damage. Any damage must be reported to CONSTRUCTION SPECIALTIES, INC., as soon as possible, so that replacement materials may be furnished without delay.

All work must be completed as per Architect's Approved "Shop Drawings", and in accordance with these Installation Instructions. When installation is complete, all materials must be protected from damage until the Architect's FINAL INSPECTION.

All materials should be arranged in the order that they are to be installed. All hardware required for each portion of the work should be placed with the appropriate materials.

Please review all Approved Shop Drawings and this Document to familiarize yourself with all the details and components of this assembly.

IMPORTANT:

READ THROUGH ALL INSTRUCTIONS PRIOR TO STARTING INSTALLATION

1/9/19



Construction Specialties™

6696 Route 405 Highway, Muncy PA 17756
(800) 233-8493 Fax (570) 546-5169 www.c-sgroup.com

This document is the property of Construction Specialties, Inc. and contains CONFIDENTIAL PROPRIETARY INFORMATION that is not to be disclosed to third parties and is not to be used without approval in writing from Construction Specialties, Inc.

Notes:

Before beginning installation, review the architectural drawings and approved Construction Specialties Inc. shop drawings to familiarize yourself with the joint cover models and locations.

Check all of the joint cover components to confirm that the correct joint cover model and size have been received. Also, check for materials that may have been damaged during shipping. Report all incorrect and/or damaged components to CS at 800-233-8493.

Read through all the steps of these instructions prior to beginning work.

STEP 1

PREPARE BLOCKOUTS

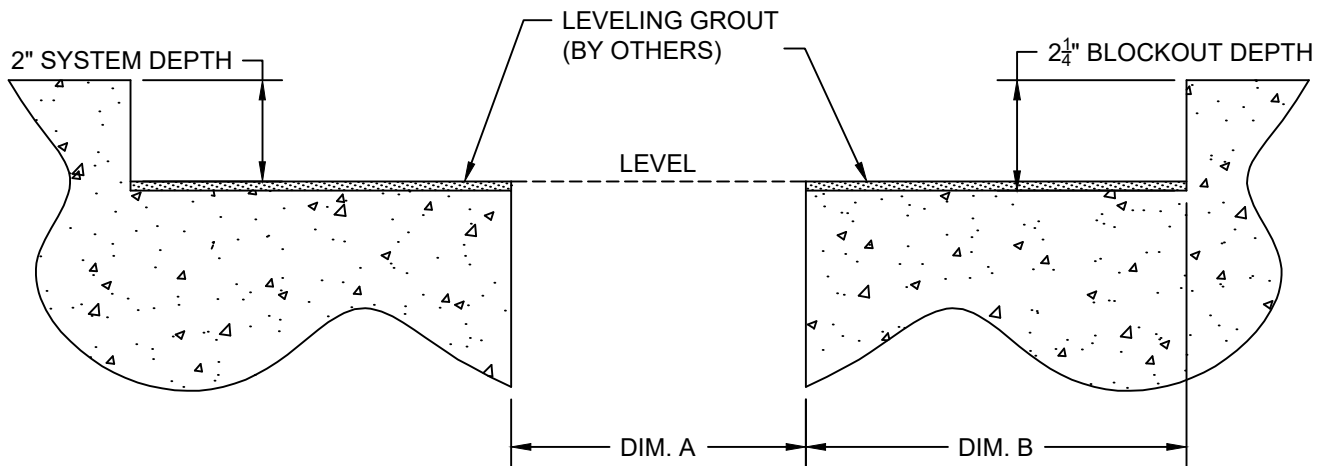

BLOCKOUT DIMENSIONS	
DIM. A	DIM. B
4"	6 ¹ / ₂ "
5" / 6"	8"

STEP 1:

- 1.1) The "KB" series joint covers are designed to take repeated vehicular traffic loading and must be securely mounted to structurally sound substrates. Repair all cracks or spawled areas of the concrete in the blockouts and in the deck adjacent to the blockout.
- 1.2) The blockouts in which the covers are to be mounted must be **flat, level and parallel**. The blockout depth should be made deeper than the actual system depth and self-leveling grout should be used to set the final depth, and to provide a smooth, flat finish. **The base of the blockout must be flat (along the length of the joint) to within $\pm \frac{1}{16}$ " and level (across the joint) to within $\pm \frac{1}{16}$ ".**
- 1.3) The surface of the blockouts must be clean and free from any loose dust, dirt, debris and oils that would affect the installation of the covers. It is recommended that the horizontal and vertical surfaces of the blockout be sandblasted to enhance the bond of the elastomeric concrete. Refer to the Elastomeric Concrete Installation Instructions for additional information.

STEP 2

INSTALL FIRST BASE FRAME

FRAME LOCATION DIMENSIONS	
DIM. A	DIM. C
4"	6"
5"	7½"
6"	7½"

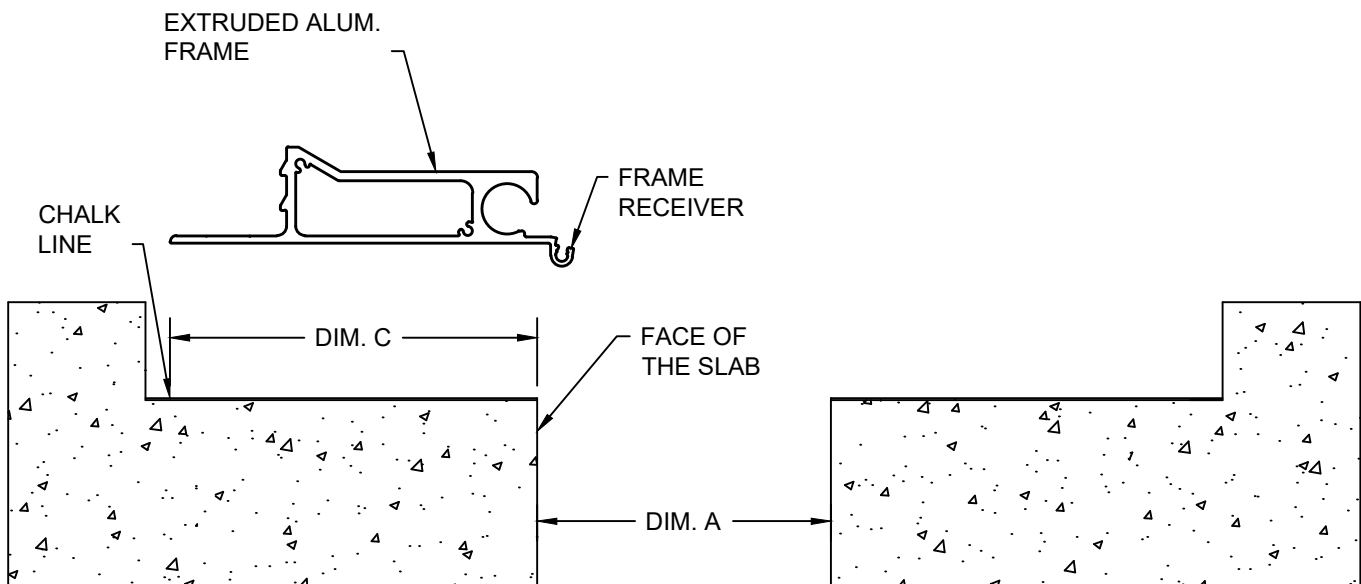

Note:

If a CS Fire Barrier is to be installed in the joint, please review the Fire Barrier Installation Instructions supplied, and if required install the Fire Barrier **BEFORE** installation of CS Seismic Expansion Joint Aluminum Frames. If a Vapor Barrier is to be installed in the joint, please review the Vapor Barrier Installation Instructions supplied, and if required install the Vapor Barrier **BEFORE** installation of CS Seismic Expansion Joint Aluminum Frames.

STEP 2:

Note: The Receiver portions of the Base Frames are to cantilever out into the joint. To establish a mounting location for the first Base Frames measure back from the face of the slab and mark the blockout at the appropriate "Frame Location Dimension" as indicated above. Snap a chalk line at the location marks.

- 2.1) Beginning at one end of the run, position a length of Frame into the blockout. The back edge of the Frame should be aligned with the chalk line. Note: The Frames have been supplied in 20'-0" lengths. Some Frames will have to be field cut to suit the specific length of the joint run.
- 2.2) Using the holes in the Frame as a template and the appropriate drill bit, drill the holes for the CS supplied Anchor Bolts. Note: Follow the appropriate installation specifications provided by the Anchor Bolt manufacturer.
- 2.3) Anchor the initial length of Frame in place.

STEP 3

INSTALL THE FRAMES

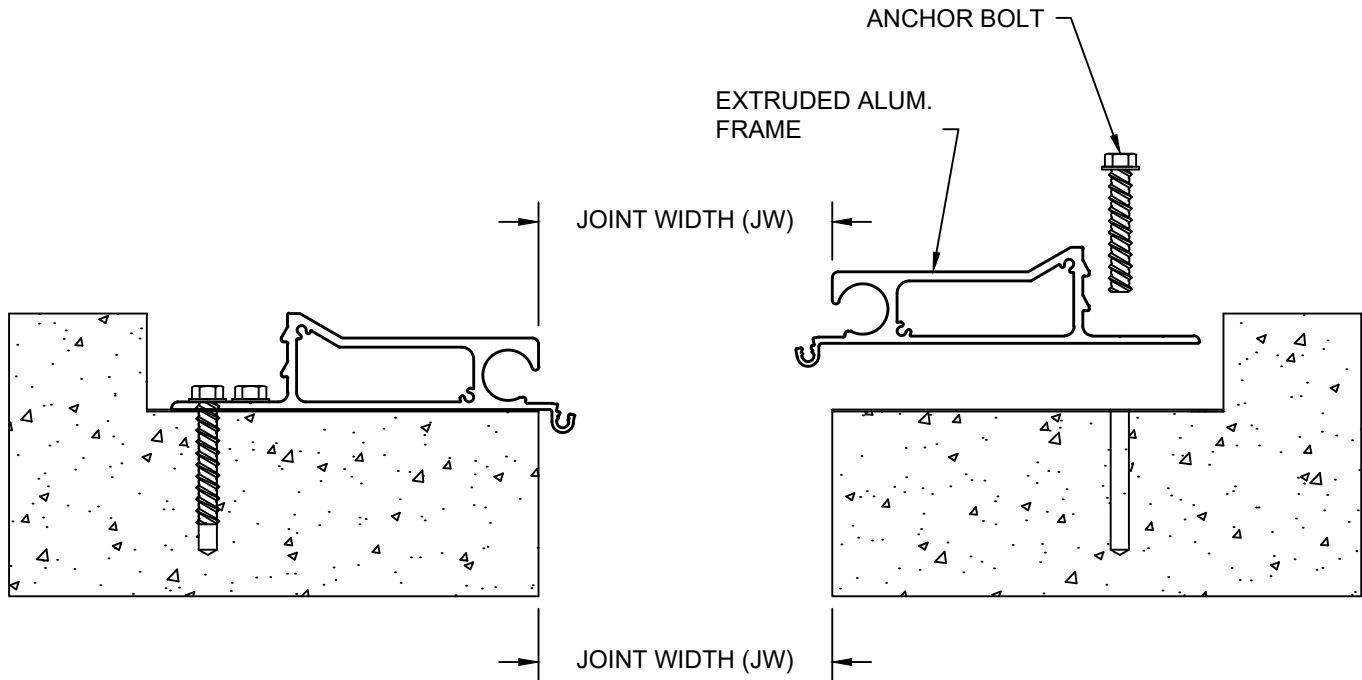

MODEL # / SIZE IDENTIFICATION	
MODEL	JOINT WIDTH
KB/KBW - 400	4"
KB/KBW - 500	5"
KB/KBW - 600	6"

STEP 3:

Note: It is important that the Frames are installed as parallel as possible. In order to maintain parallelism, the opposite Frame is to be located off the first Frame at a dimension equal to the specified joint width.

- 3.1) Beginning at the end of the run, position a length of the Frame in the blockout. The front edge of the Frame should be located so that the specified joint width is maintained between the Frames.
- 3.2) While maintaining the Frames at parallel, use the holes in the Frame as a template and drill the holes for the CS supplied Anchor Bolts.
- 3.3) Anchor the Frame in place per the installation guidelines of the Anchor Bolt manufacturer.

Note: It is suggested that the Frames be installed in pairs, one on each side of the joint, to facilitate installation of the Turnbars as described in Step 5.

STEP 4

VAPOR BARRIER INSTALLATION

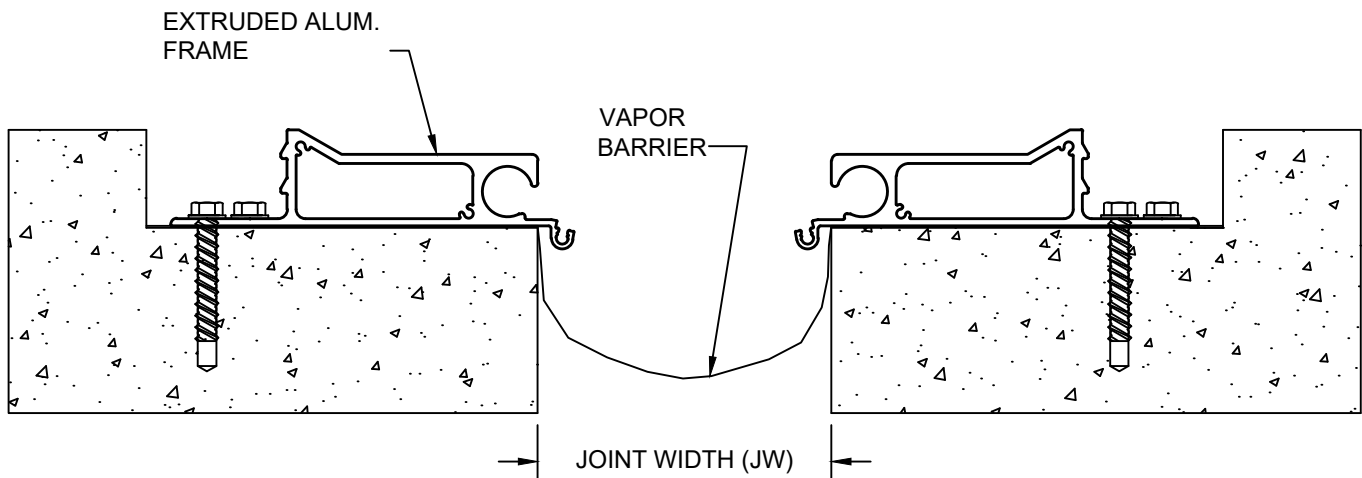

Note: The Vapor Barrier should be in as long of runs as possible to reduce the number of splices. All sizes of water stop are provided in 100' rolls. Special installation instructions are provided for splicing, drain installation and end closures. See these instructions if any of these conditions are required.

STEP 4:

- 4.1) Vapor Barrier must be installed in conjunction with Expansion Joint Cover Framework. Prior to starting installation prepare the face of the slabs by removing any loose debris, oil, or grease.
- 4.2) Place the Vapor Barrier in the bottom of the blockout, installing to the ends of the frames. Hold the Vapor Barrier in place with duct tape.
- 4.2) Drape the Vapor Barrier material down into the joint. It may be necessary to place a small block of wood or a tool in the drape to hold it down into the joint until the installation of the frames is complete.
- 4.3) Floor to Wall installation of Vapor Barrier follow instructions above for the blockout side. Run the wall Vapor Barrier so that the Vapor Barrier extends to the end of the wall frame and hold in place with duct tape until the wall frame is installed.

STEP 5

INSERT TURNBARS

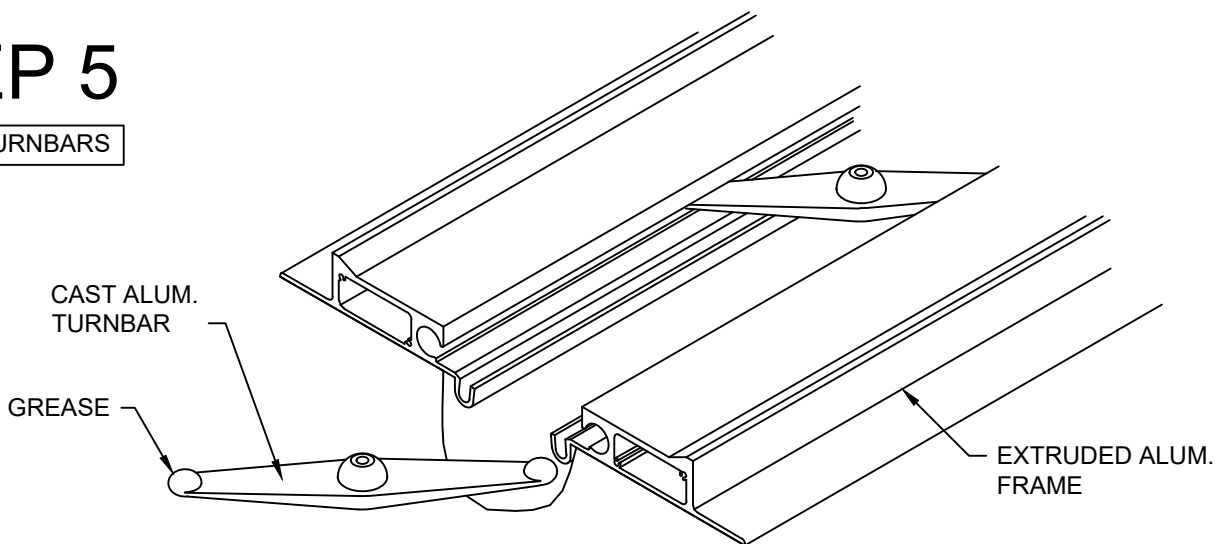

STEP 5:

Note: The Turnbars, which attach the Cover Plates to the Frames, are positioned at 18" O.C. There will be (7) Turnbars required for each 10' length of Cover Plate. One custom Turnbar (the threads have been drilled out at the center hole) is required for attachment of each End Plate. **Note:** End Plates are required only when lateral shear movement is specified. Please refer to the CS shop drawings for End Plate requirements.

- 5.1) Before inserting the Turnbars into the Frames, apply a thin coating of white lithium grease (not supplied) to the entire surface of the ball at each end of the bar.
- 5.2) Beginning at the open end of the pair of Frames, slide in the appropriate number of Turnbars. Begin with a custom Turnbar where needed for attachment of the End Plates. Note the orientation of the Turnbar on the detail above, the semi-sphere portion at the center of the bar is to be facing up.

STEP 6

INSTALL ADJACENT FRAMES

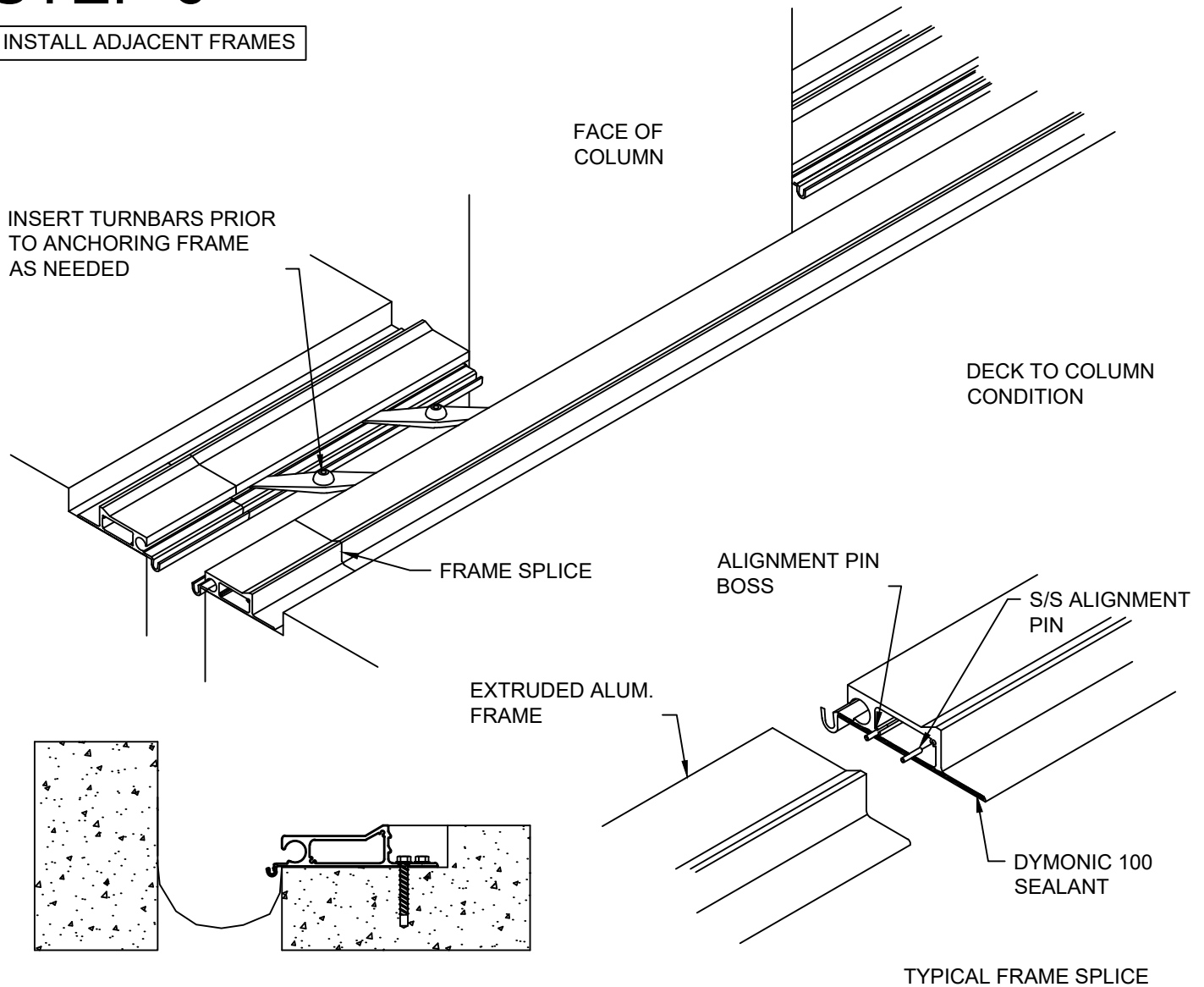

STEP 6:

- 6.1) Before installing the adjacent length of Frames, insert an grooved Alignment Pin into each of the bosses in the Frame extrusion. Insert the grooved end of Pin approximately one half of its length.
- 6.2) Apply a small bead of Dymonic 100 Sealant along the bottom edge of the Frame. Note: This sealant will prevent water leakage between the Frames.
- 6.3) Position the Frame in the blockout and insert the Alignment Pin into the extrusion bosses of the previous Frame and butt the Frames tightly together.
- 6.4) Align the back edge of the Frame with the chalk line and anchor the new length of Frame to the blockout as instructed in Step 1.
- 6.5) Insert Alignment Pins, position and anchor the next length of Frame at the opposite side of the joint.
- 6.6) Install the Vapor Barrier to the ends of the Frames and insert the appropriate Turnbars as instructed in Steps 4 and 5.
- 6.7) Continue installing lengths of Frames and Turnbars for the remaining length of the run. Cut the Frames to the appropriate length where required.

Note: Where deck to column or deck to wall conditions occur (Model "KBW"), the Frame on one side of the joint will be interrupted. Caution: At these conditions, it may be necessary to insert the Turnbars prior to anchoring the Frame. Custom End Plate Turnbars will also be required.

STEP 7

INSTALL END PLATES

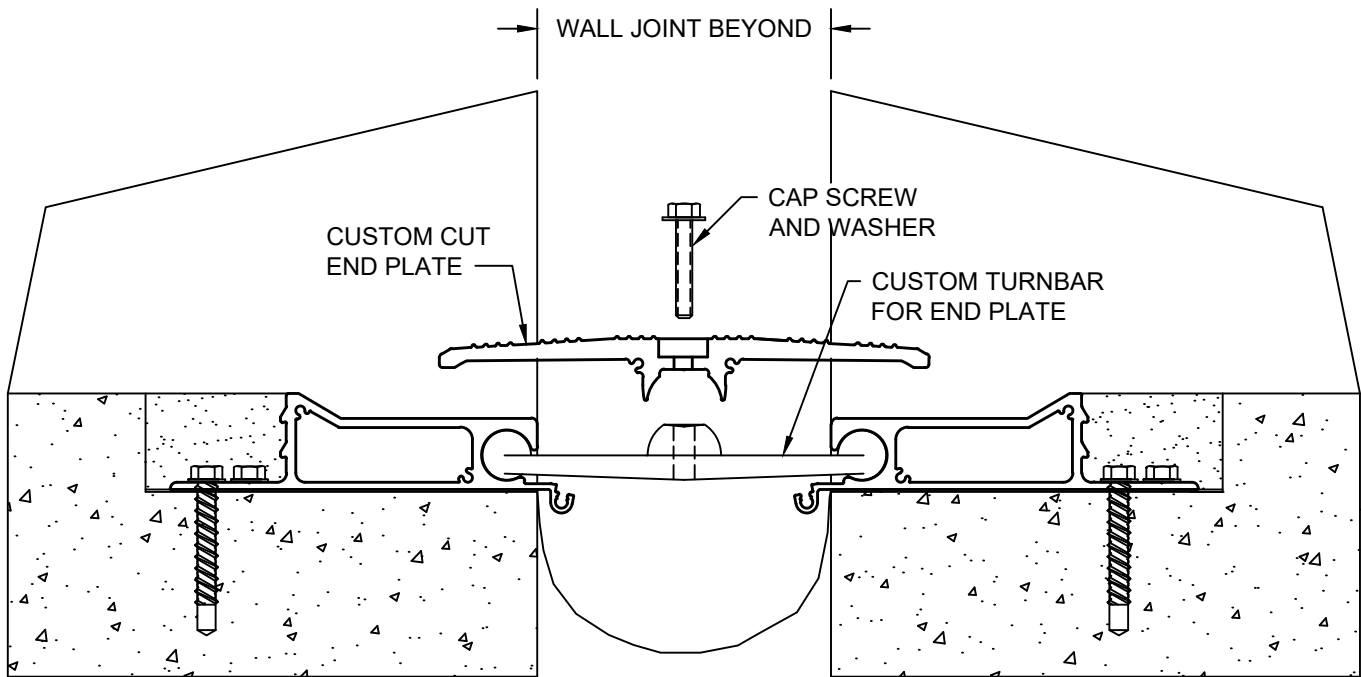

STEP 7:

Note: End Plates are required at each end of each run of joint cover and adjacent to wall/column conditions to allow for lateral movement of the joints during a seismic event. Place the End Plates where indicated on the approved CS shop drawings. End Plates for KB-400 and KB-500 are 12" and for KB-600 is 18".

- 7.1) Position the center of the End Plate Turnbar approx. 6" in from the face of the wall.
- 7.2) Position the custom cut End Plate so that it is centered over the joint with the square cut end of the Plate against the wall or column.
- 7.3) Working down through the screw hole in the center of the End Plate, align the center hole of the Turnbar with the hole in the Plate. Note: The semi-sphere in the top of the Turnbars should be seated in the semicircular recess on the bottom of the Plate.
- 7.4) Place a Cap Screw and Washer (CS supplied) in the hole in the Plate and through the hole in the Turnbar.

STEP 8

INSTALL COVER PLATES

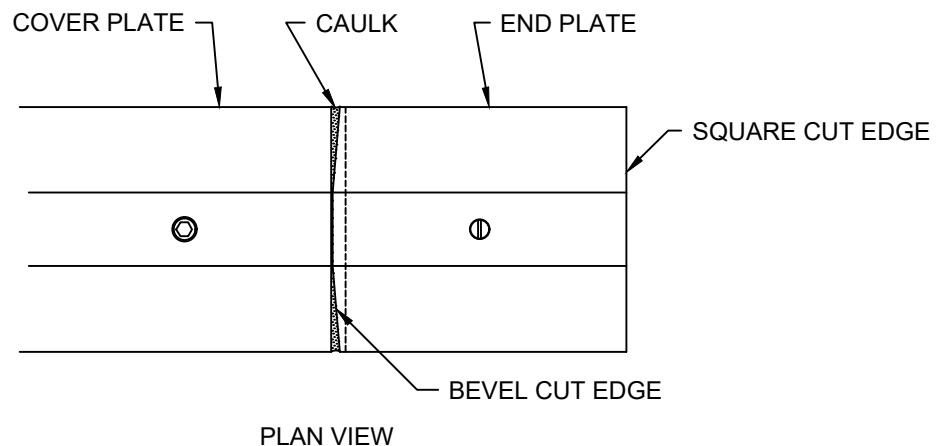
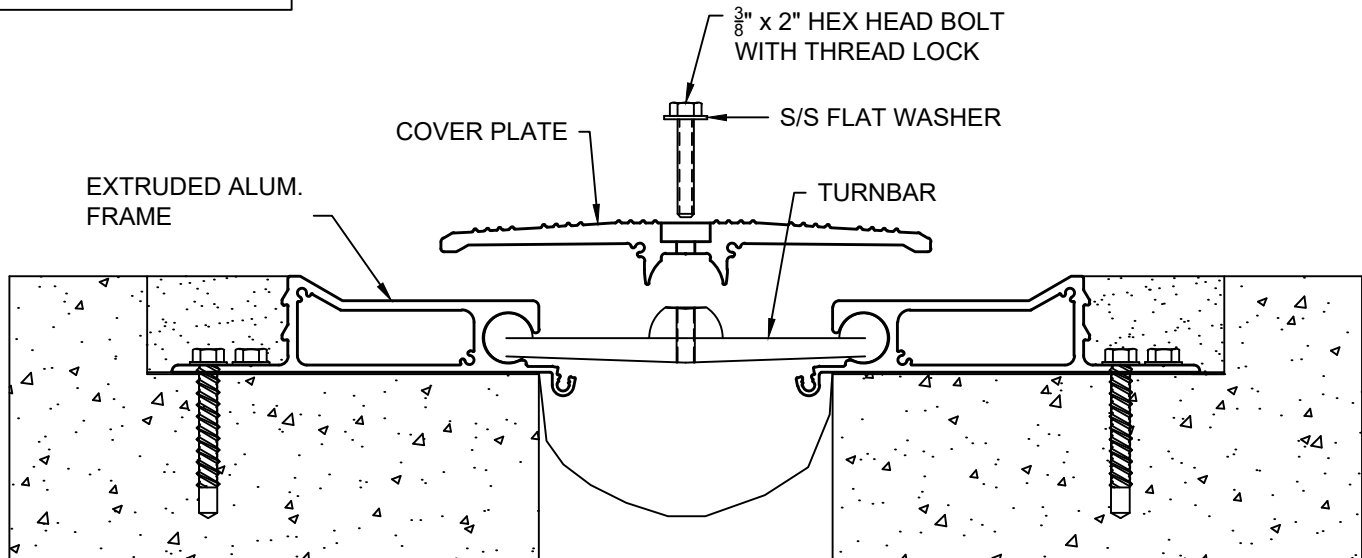

STEP 8:

Note: The Cover Plates have been supplied in either 10'-0" or 20'-0" lengths. Some Plates may have to be cut to length to suit the specific length of a run. When cutting Plates, a minimum of (2) Turnbar holes must be maintained for the Plate to function properly during seismic movement.

- 8.1) Beginning at the end of the run adjacent to the End Plate, place the first length of Cover Plate on the concrete deck, parallel to the joint. Align the end of the Plate with the beveled end of the End Plate.
- 8.2) Slide the Turnbars so that the center hole of each Turnbar is approximately aligned with each center bolt hole in the Cover Plate.
- 8.3) Position the Cover Plate over the joint with the Plate resting on the Frames and the semi-sphere portion of the Turnbars positioned in the recessed area on the bottom of the Cover Plate.
- 8.4) Working through the center bolt holes of the Cover Plate with a stiff wire, screwdriver or drift pin, align the center holes of each Turnbar with the hole in the Cover Plate.
- 8.5) Place a S/S Flat Washer on each 2" Hex Head Cap Screw (CS supplied), insert a Cap Screw through each hole and partially thread into each Turnbar. **Note:** Do not tighten until all of the Cap Screws have been started as some adjustment of the alignment of the center holes and Turnbars may be required.
- 8.6) With all the center Cap Screws for this length of Plate in place, tighten the Screws by hand and torque to 40 ft. lbs. **Note:** Over torquing the Screws may cause damage to the system.
- 8.7) Continue with installation of adjacent Plates. Use Alignment Pins, placed in the bosses on the underside of the Plate, to maintain alignment of the Plate edges.

Note: Due to the bevel cut on the lead edge of the End Plate, there will be a tapered gap between the End Plate and the adjacent Plate. This gap should be filled with a silicone caulk.

STEP 9

INSTALL "KBW" COVER PLATES

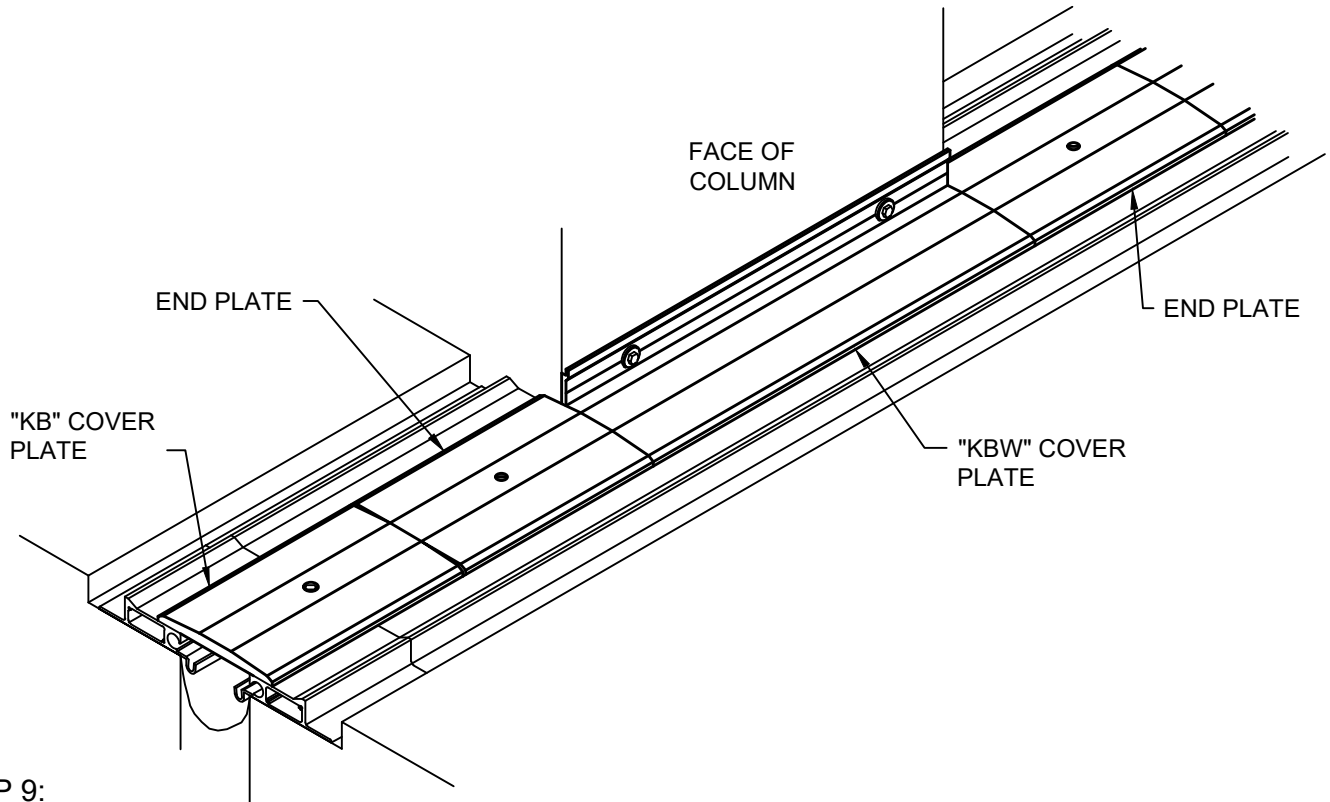
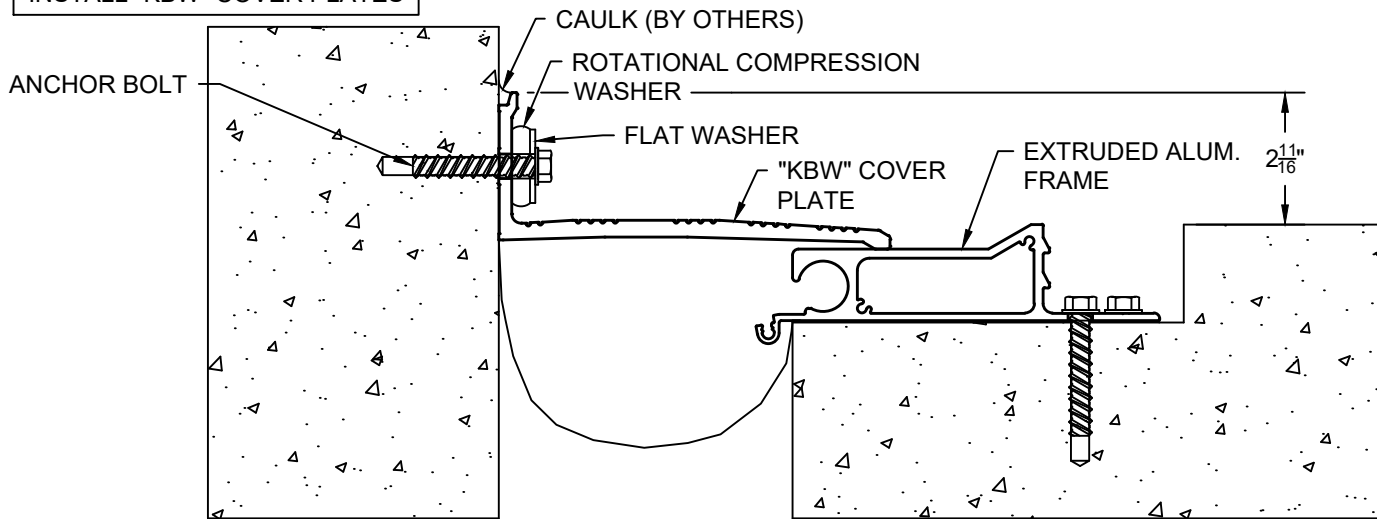

STEP 9:

- 9.1) Note: The Cover Plates have been supplied in 10'-0" lengths. Some Plates may have to be cut to length to suit the specific length of a run.
- 9.2) Cut a length of "KBW" Cover Plate to the length needed for the run.
- 9.3) Position the Cover Plate on top of the Frame and against the face of the wall or column. Using the Cover Plate as a template, drill the holes for the CS supplied Anchor Bolts.
- 9.4) Place a large diameter Flat Washer and a Rotational Compression Washer (rubber) onto each Anchor Bolt, and anchor the Cover Plate to the wall or column.
- 9.5) Apply a silicone caulk (by others) along the top edge of the Cover Plate.

STEP 10

APPLY ELASTOMERIC CONCRETE

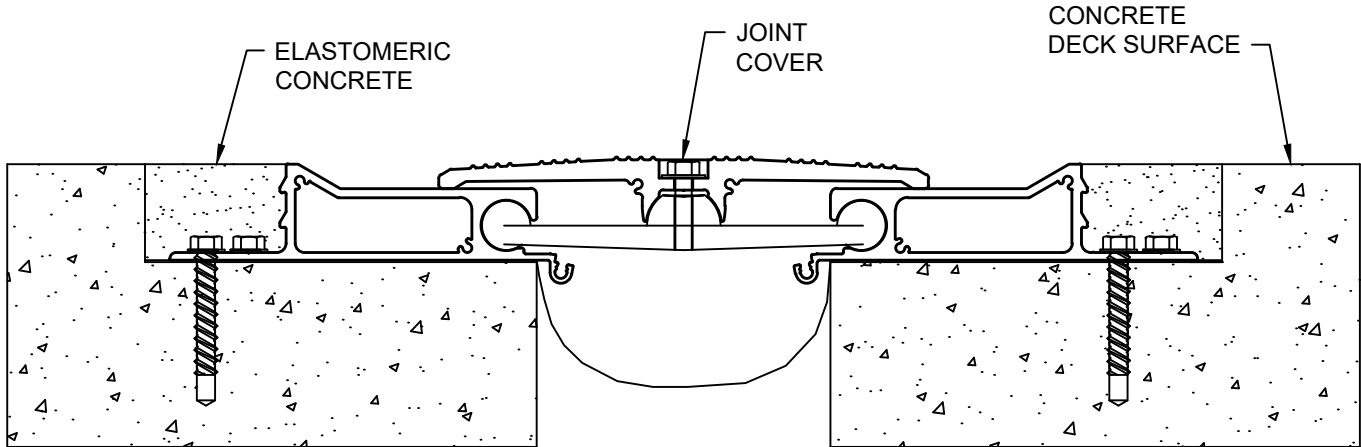

STEP 10:

Note: The Elastomeric Concrete will stain the surface of the Joint Cover and the surrounding concrete deck. To prevent staining, it is recommended that you mask off the entire surface of the Joint Cover and the surface of the concrete deck adjacent to the breakout before applying the Elastomeric Concrete.

- 10.1) Application of the Elastomeric Concrete is to be done in accordance with the Elastomeric Concrete Application Instructions provided separately.
- 10.2) Once the Elastomeric Concrete has begun to harden, the masking can be removed from the Joint Cover and deck.

THIS WILL COMPLETE THE INSTALLATION OF THIS RUN OF THE "KB" SERIES JOINT COVER.