

HRW-10C / V / G HANDRAIL

WITH INTERNATIONAL OFFSET

PLEASE READ

PLEASE READ THESE INSTRUCTIONS THOROUGHLY PRIOR TO BEGINNING THE HRW-10C / V / G HANDRAIL INSTALLATION!

THIS INSTRUCTION SHEET IS INTENDED TO PROVIDE A SPECIFIC GUIDE TO FOLLOW FOR THE INSTALLATION OF THIS HRW-10C / V / G HANDRAIL. CONTAINED WITHIN IS THE TECHNICAL INFORMATION AND INSTALLATION TECHNIQUES REQUIRED TO COMPLETE AN EFFICIENT, NEAT AND LONG-LASTING INSTALLATION.

INSPECT ALL MATERIALS FOR DAMAGE OR MISSING PARTS. IF YOU DISCOVER DAMAGED OR MISSING MATERIALS, IN THE USA PLEASE NOTIFY THE FACTORY AT (800) 233-8493, AND IN CANADA (888) 895-8955 FOR CUSTOMER SERVICE.

HRW-10C / V / G HANDRAIL MUST BE INSTALLED IN ACCORDANCE WITH THESE INSTRUCTIONS! FAILURE TO FOLLOW THESE INSTRUCTIONS MAY VOID ANY PRODUCT WARRANTIES AND RESULT IN AN UNSUCCESSFUL INSTALLATION. FOR SPECIFIC QUESTIONS REGARDING THE INSTALLATION OF THIS HRW-10C / V / G HANDRAIL PLEASE CALL THE FACTORY IN THE USA AT (800) 233-8493 OR EMAIL IWPTECHSUPPORT@C-SGROUP.COM. IN CANADA CALL (888) 895-8955.

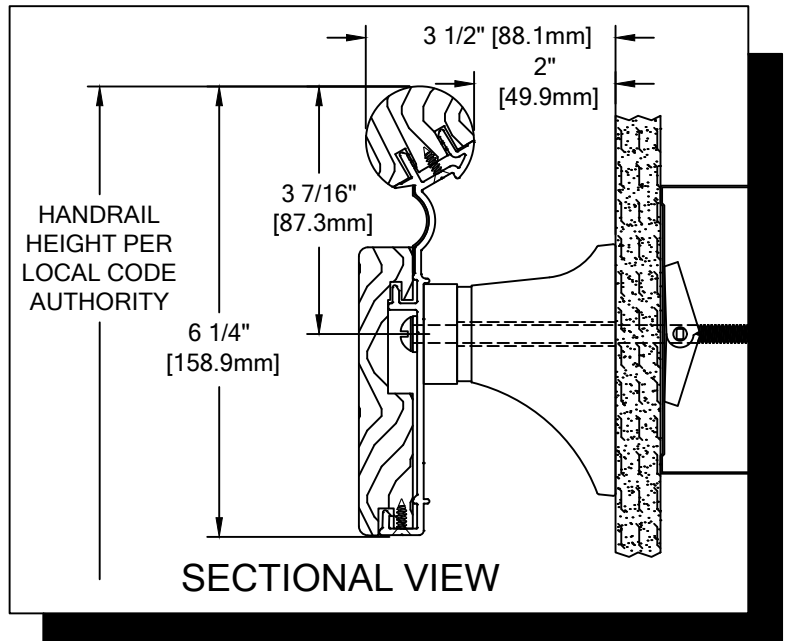

*HRW-10C SHOWN SEE PAGE 4 FOR HRW-10CV AND HRW-10CG

IMPORTANT NOTES

1. DUE TO WOOD BEING A NATURAL PRODUCT, COMPONENTS MAY GROW AND SHRINK AT DIFFERENT RATES. BECAUSE OF THIS, C/S HAS DESIGNED THIS HANDRAIL TO UTILIZE A BEVEL AS SHOWN IN THESE INSTRUCTIONS (SEE FIGURE 1). THIS BEVEL MUST BE APPLIED AT ALL WOOD JOINTS AND MUST MATCH FACTORY BEVEL ON END CAPS.
2. DUE TO THE NATURE OF WOOD, COMPONENT COLORS MAY VARY. SORT WOOD COMPONENTS AND MATCH PARTS BY COLOR.
3. ALL LINEAL MATERIAL TO BE SUPPLIED IN STOCK LENGTHS. WOOD IN 7'-0" TO 12'-0" VARIABLE, AND ALUMINUM IN LENGTHS UP TO 20'-0". THIS MATERIAL IS TO BE FIELD CUT USING QUALITY EQUIPMENT TO INSURE THAT ALL CUTS ARE SQUARE. WHEN CUTTING MATERIAL SECTIONS, C/S RECOMMENDS USING AN 80-100 TOOTH CARBIDE TIPPED SAW BLADE OR EQUIVALENT, TO MINIMIZE CHIPPING AND MAINTAIN JOINT ALIGNMENT.
4. RADIAL MATERIAL MAY BE SUPPLIED FACTORY FORMED OR IN STRAIGHT LENGTHS FOR FIELD FORMING. CONSULT FACTORY FOR OPTIONS.
5. ALL DIMENSIONS ARE TYPICAL.
6. FOR DRYWALL/PLASTER WALL CONSTRUCTION, IT IS RECOMMENDED FOR FASTENERS TO BE ENGAGED INTO METAL/WOOD STUDS TO MAINTAIN MAXIMUM PULLOUT STRENGTH. IF DURING INSTALLATION YOU ENCOUNTER SPECIAL WALL CONDITIONS THAT DO NOT ALLOW FOR DIRECT ATTACHMENT TO THE STUDS, PLEASE CONSULT THE LOCAL AUTHORITY HAVING JURISDICTION.
7. INSTALL OUTSIDE CORNERS FIRST.
8. INSTALL LONGEST RUN OF HANDRAIL FIRST.
9. MATERIAL MUST REACH 65°F MIN. TO 75°F MAX. 24 HOURS PRIOR TO INSTALLATION. THIS IS ESSENTIAL TO MINIMIZE EXPANSION AND CONTRACTION OF MATERIAL.
10. MAY REQUIRE USE OF FIRE PUTTY WHEN INSTALLED ON FIRE WALL WITH TOGGLE BOLTS. REFERENCE INSTRUCTIONS 24FIREPUTTY FOR FIRE PUTTY INSTALLATION.
11. THIS HANDRAIL REQUIRES A MINIMUM OF 2 MOUNTING BRACKETS PER UNIT. THE MINIMUM END CAP-TO-END CAP CRASH RAIL LENGTH IS 12" [304.8mm].
12. FOR MORE INFORMATION ON HRW-10C HANDRAIL SEE OUR WEBSITE AT www.c-sgroup.com.

HRW-10C / V / G HANDRAIL

COMPONENTS & WALL FASTENERS



WOOD HANDRAIL
(24W001xxx)



WOOD CRASH RAIL
(24W002xxx-GROOVED)
(24W009xxx-PLAIN)

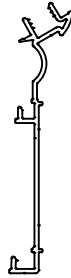

ALUMINUM RETAINER
(24A355000)

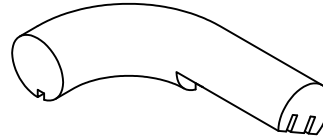

WOOD HANDRAIL ENDCAP
(24W442xxx-RH, SHOWN)
(24W443xxx-LH)

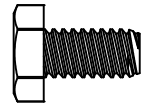

FASTENER #1
1/4-20 X 1/2"
S/S HEX HEAD
MACHINE SCREW
(90H052006)

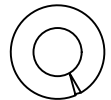

FASTENER #2
1/4" LOCK WASHER
(90H006003)



WOOD HANDRAIL
OUTSIDE CORNER
(24W017xxx)



MOUNTING BRACKET
(24I007xxx)



FEATURE INSERT
(24V011xxx)



BRACKET EXTENSION
(24I080000)



ACROVYN ACCENT
REVEAL
(24N021xxx)
(24N021xxxF)

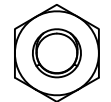

FASTENER #3
1/4-20 HEX NUT
(90H010001)

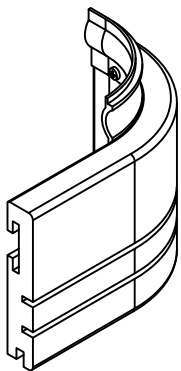

WOOD CRASH RAIL ENDCAP
(24W133xxx-RH GROOVED, SHOWN)
(24W134xxx-LH GROOVED)
(24W131xxx-RH PLAIN)
(24W132xxx-LH PLAIN)

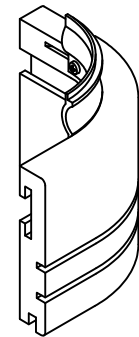

WOOD CRASH RAIL
OUTSIDE CORNER
(24W006xxx-GROOVED)
(24W021xxx-PLAIN)

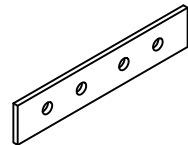

RETAINER SPLICE BAR
(24I976000)

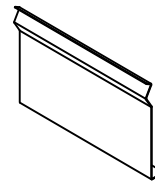

DRILLING JIG TEMPLATE
(95M008000)

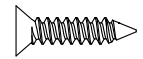

FASTENER #4
#6 X 5/8" S/S PHILLIPS
FLAT HEAD SMS
(90H231004)

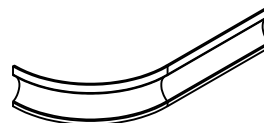

END CAP REVEAL
(24I061xxxF - RH)
(24I062xxxF - LH, SHOWN))

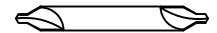

#4 X 1/2" HSS
COUNTERSINK DRILL
(90H035010)

WALL CONDITION	SPECIFIED FASTENER	DRILL DIAMETERS		C/S PART NUMBER
		WALL	RETAINER	
STEEL STUD/GYPSUM WALL	1/4-20 X 5" ROUND HEAD BOLT WITH TOGGLE 1/4" LOCK WASHER	3/4"	N/A	90H049002 90H006003
CONCRETE/CONCRETE BLOCK	#14 X 5" S/S PHILLIPS RD HD ALL-PURPOSE SCREW	3/16"	N/A	90H287006
WOOD STUD/GYPSUM WALL	#14 X 5" S/S PHILLIPS RD HD ALL-PURPOSE SCREW	1/8"	N/A	90H287006

HRW-10C / V / G HANDRAIL

LAYOUT VIEW

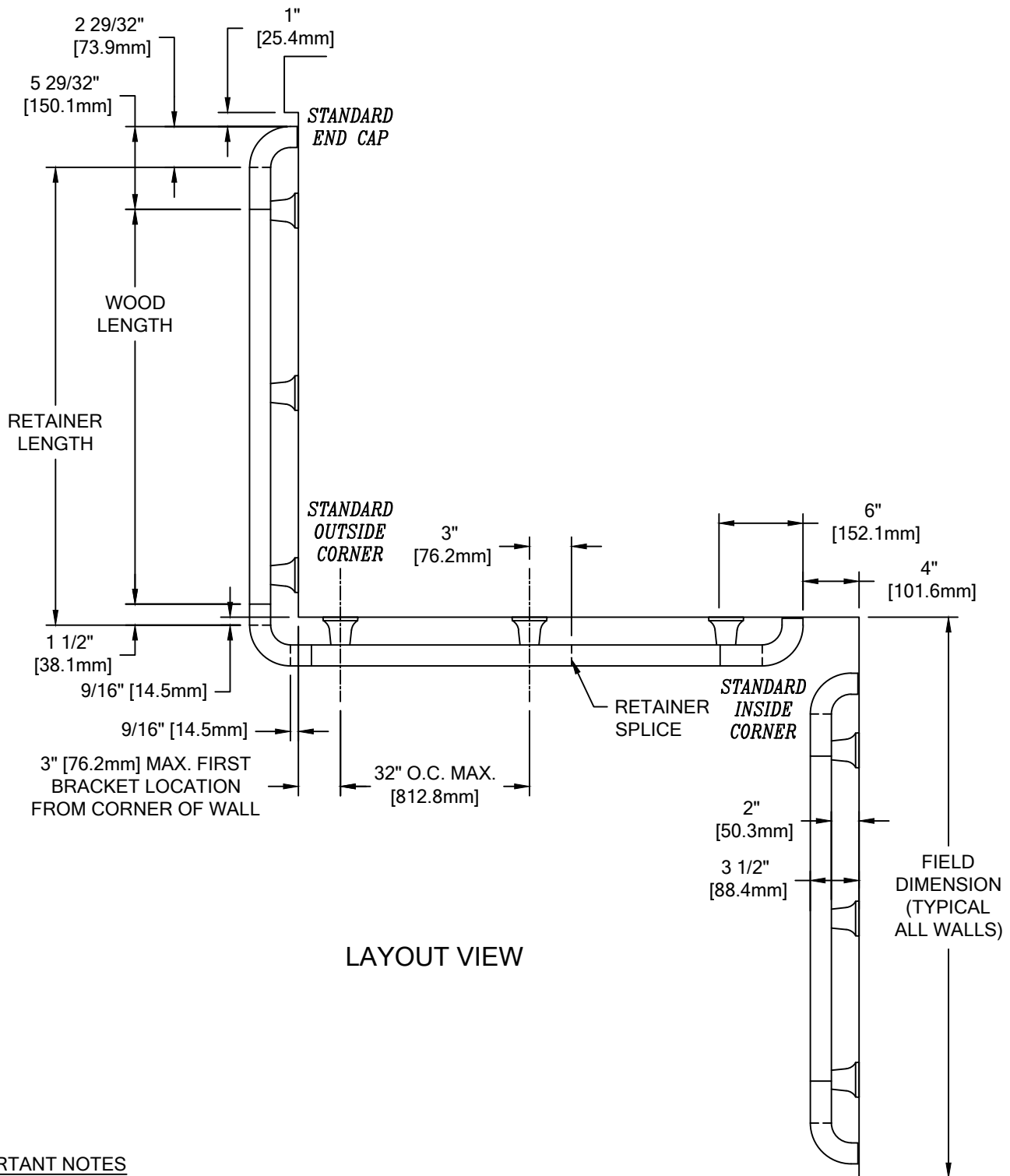

LAYOUT VIEW

IMPORTANT NOTES

1. ALUMINUM RETAINER SPLICES SHOULD NOT EXCEED 3" [76.2mm] DISTANCE FROM A BRACKET.
2. THE DISTANCE BETWEEN A WOOD SPLICE JOINT AND AN ALUMINUM RETAINER SPLICE JOINT SHOULD NOT BE LESS THAN 12" [304.8mm].
3. TANGENT POINTS ON FACTORY FORMED RADIAL MATERIAL WILL BE MARKED APPROXIMATELY AND SHOULD BE CUT TO SUIT FIELD CONDITIONS.

HRW-10C / V / G HANDRAIL

TYPICAL ASSEMBLY

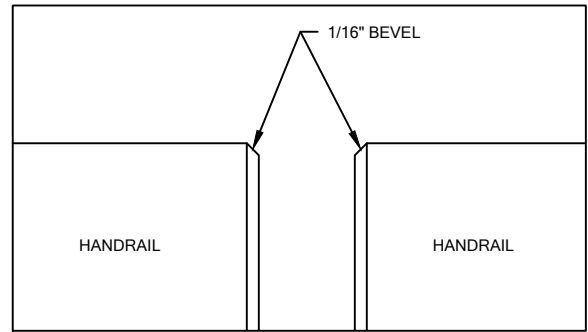
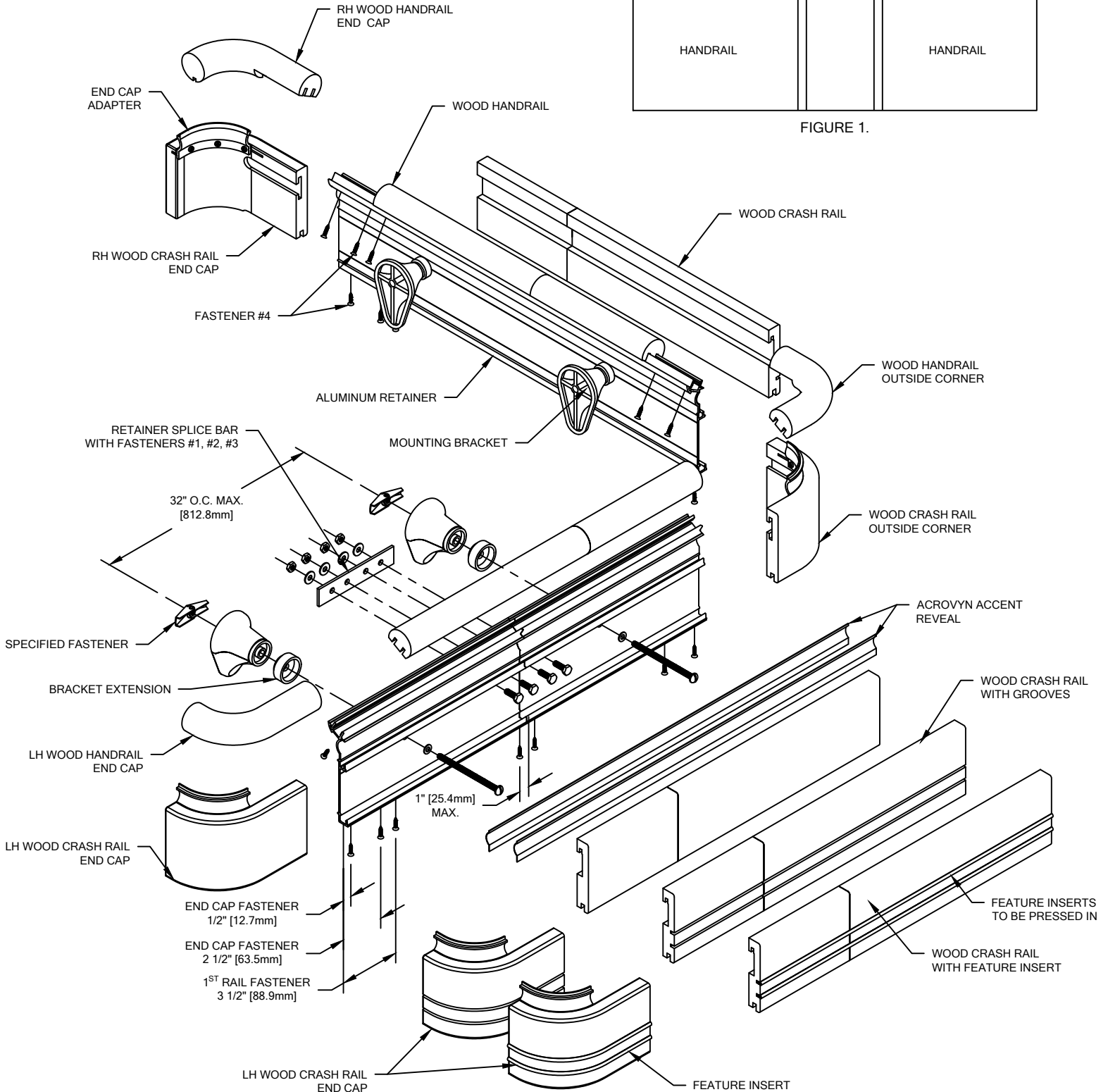

FIGURE 1.



HRW-10C / V / G HANDRAIL

NOTE: INSTALLATION OF LINEAL OR RADIAL HRW-10C HANDRAIL SHOULD BE DONE IN ACCORDANCE WITH THE FOLLOWING INSTRUCTIONS.

1. USE LOCAL CODE REQUIREMENTS AND ESTABLISH HANDRAIL HEIGHT ABOVE FINISH FLOOR. DEDUCT 3 7/16" [87.3mm] AND SNAP A CHALK LINE AT THAT HEIGHT. THIS MARKS THE LOCATION OF THE MOUNTING BRACKET FASTENERS.
2. CUT THE CONTINUOUS RETAINER TO LENGTH USING THE REQUIRED DEDUCTIONS AS NOTED (SEE LAYOUT VIEW). PRE-DRILL CLEARANCE HOLES IN THE ALUMINUM RETAINER FOR THE MOUNTING BRACKETS 3" [76.2mm] FROM EACH END AND 32" [812.8mm] O.C. AS REQUIRED AT THE V-GROOVE ALONG THE FRONT OF THE RETAINER. FILE ALL ENDS OF RETAINER TO REMOVE BURRS AND SHARP EDGES AT HANDRAIL.

NOTE: IT IS RECOMMENDED THAT THE ALUMINUM RETAINER BE CUT WITH AN 80-100 TOOTH CARBIDE TIPPED SAW BLADE OR EQUIVALENT.

3. A TEMPLATE IS SUPPLIED TO LOCATE HOLES IN THE RETAINER FOR FASTENING WOOD COMPONENTS (SEE ILLUSTRATION BELOW). USE THE SUPPLIED COUNTERSINKING DRILL FOR HOLES WHERE WOOD COMPONENTS ARE TO BE FASTENED TO RETAINER. THIS WILL ALLOW SCREW HEADS TO BE FLUSH WITH RETAINER WHEN ASSEMBLED. COUNTERSUNK HOLES FOR WOOD RAIL NEED TO BE 24" ON CENTER MAX. REMOVE ANY BURRS LEFT FROM DRILLING AND COUNTERSINKING HOLES IN RETAINER.
4. DRILL CLEARANCE HOLES IN WALL SURFACE FOR MOUNTING HARDWARE, USING THE RETAINER AS A TEMPLATE. REFERENCE CHART ON PAGE 2 FOR CORRECT DRILL DIAMETER.
5. APPLY (2) ACCENT REVEALS TO RETAINER USING DOUBLE-FACED TAPE. ACCENT REVEALS ARE TO BE PLACED TOGETHER ON THE RETAINER.

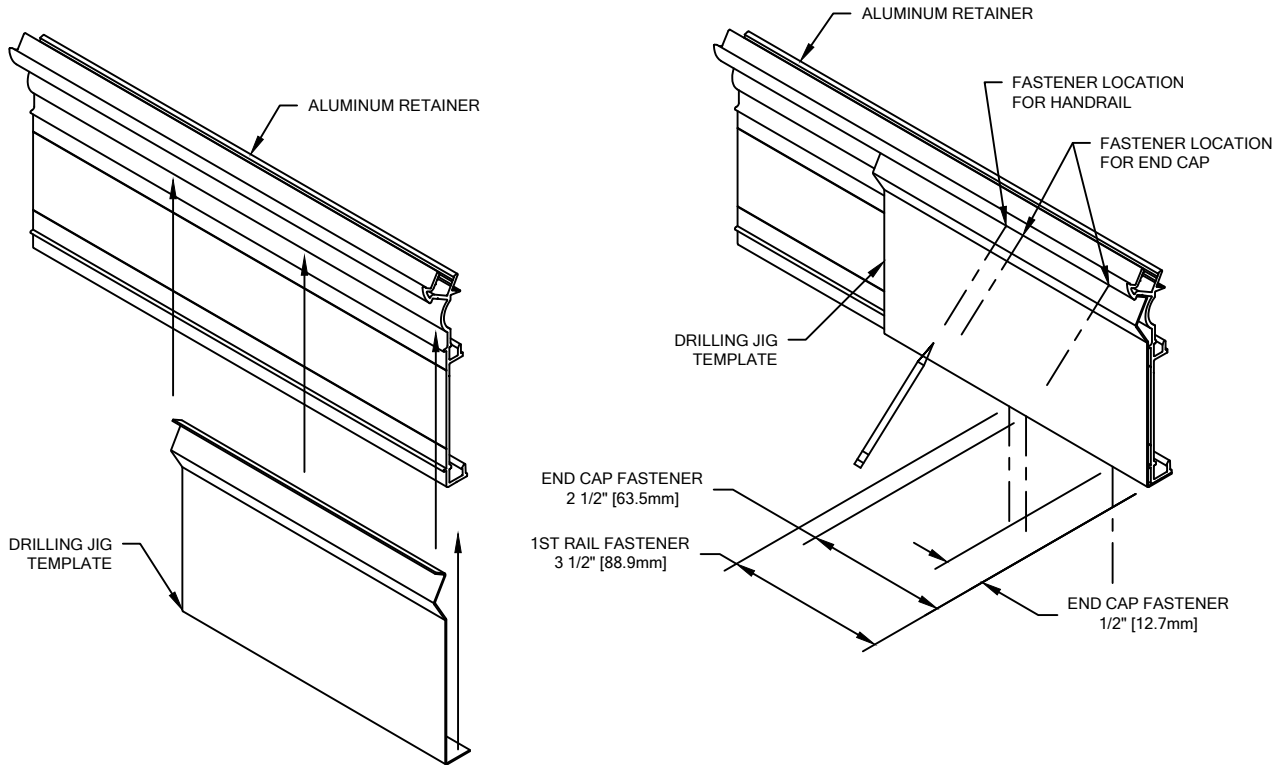

HRW-10C / V / G HANDRAIL

6. ATTACH CRASH RAIL END CAPS/OUTSIDE CORNER TO EACH END OF RETAINER. USING THE HOLE IN THE RETAINER AS A GUIDE, DRILL 3/32" DIAMETER PILOT HOLES 3/8" DEEP INTO THE CRASH RAIL END CAP TO ACCEPT THE #6 X 5/8" PHILLIPS FLAT HEAD SHEET METAL SCREWS.
7. ATTACH HANDRAIL END CAPS/OUTSIDE CORNER. THIS CAP FITS ONTO RETAINER AS WELL AS THE TOP OF THE MAIN BODY ADAPTER. USING THE HOLE IN THE RETAINER AS A GUIDE, DRILL 3/32" DIAMETER PILOT HOLES 3/8" DEEP IN THE HANDRAIL END CAP TO ACCEPT THE #6 X 5/8" SCREWS.
8. CUT THE WOOD HANDRAIL TO LENGTH USING THE REQUIRED DEDUCTIONS (REFERENCE LAYOUT VIEW). BEVEL THE HANDRAIL EDGES SLIGHTLY WITH 150 GRIT SANDPAPER (SEE FIGURE 1). TOUCH UP SANDED EDGES WITH SUPPLIED STAIN MARKER.
9. USING THE HOLE IN THE ALUMINUM RETAINER AS A GUIDE, DRILL 3/32" DIAMETER PILOT HOLES 3/8" DEEP IN THE TOP WOOD HANDRAIL TO ACCEPT THE #6 X 5/8" SCREWS. ATTACH THE WOOD HANDRAIL TO THE RETAINER USING THE SUPPLIED SCREWS.
10. INSTALL EACH SECTION OF ASSEMBLED RETAINER IN SUCCESSION USING THE ACROVYN MOUNTING BRACKETS, BRACKET EXTENSIONS, AND APPROPRIATE FASTENERS. REFERENCE CHART ON PAGE 2. USE A LEVEL TO ASSURE RETAINER IS LEVEL.

NOTE: WHEN FIELD FORMING RADIUS HANDRAIL, BE SURE TO APPLY NEEDED PRESSURE FROM BRACKET TO BRACKET.

11. CUT THE WOOD CRASH RAIL TO LENGTH USING THE REQUIRED DEDUCTIONS (REFERENCE LAYOUT VIEW). BEVEL THE CRASH RAIL EDGES SLIGHTLY WITH 150 GRIT SANDPAPER (SEE FIGURE 1). TOUCH UP SANDED EDGES WITH SUPPLIED STAIN MARKER.
12. USING THE HOLE IN THE ALUMINUM RETAINER AS A GUIDE, DRILL 3/32" DIAMETER PILOT HOLES 3/8" DEEP IN THE BOTTOM WOOD CRASH RAIL TO ACCEPT THE #6 X 5/8" SCREWS. ATTACH THE WOOD CRASH RAIL TO THE RETAINER USING THE SUPPLIED SCREWS.

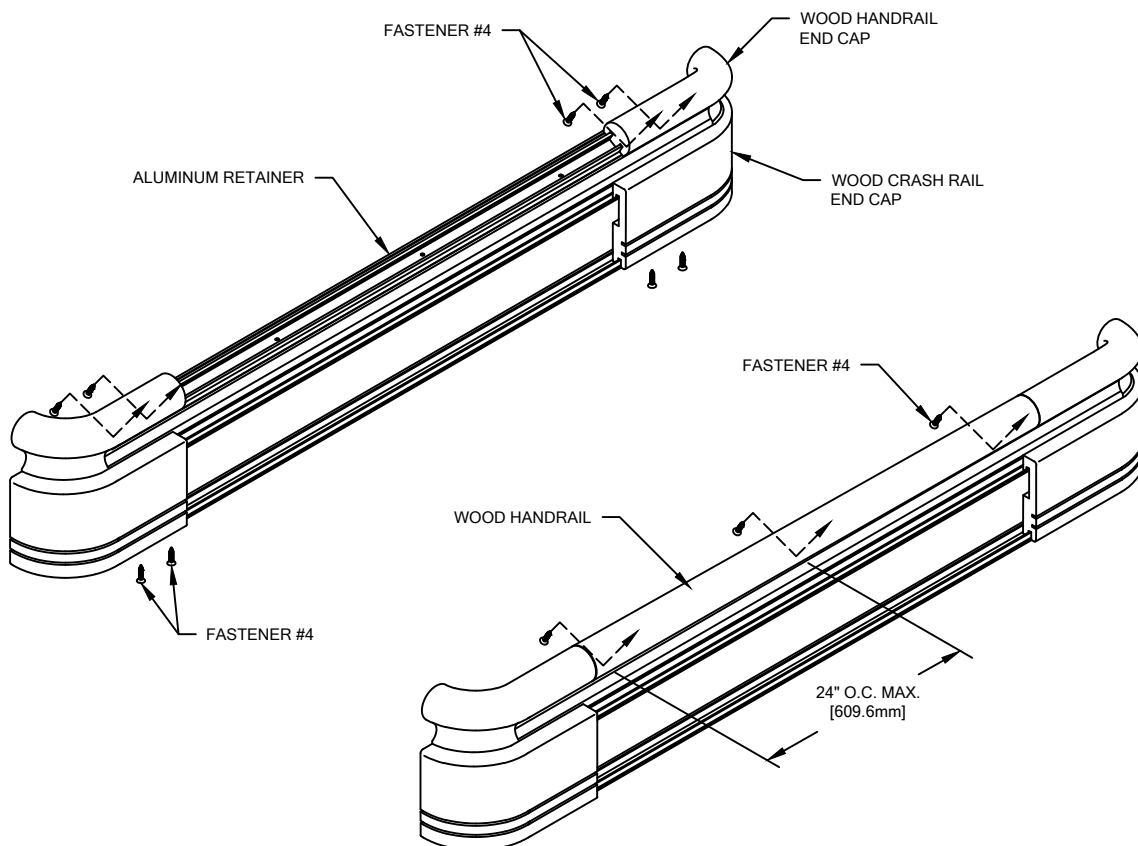

HRW-10C / V / G HANDRAIL

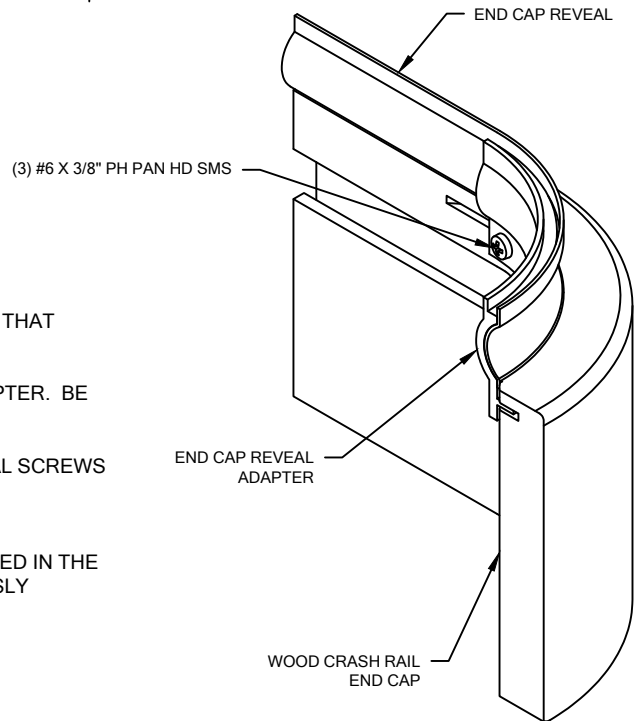
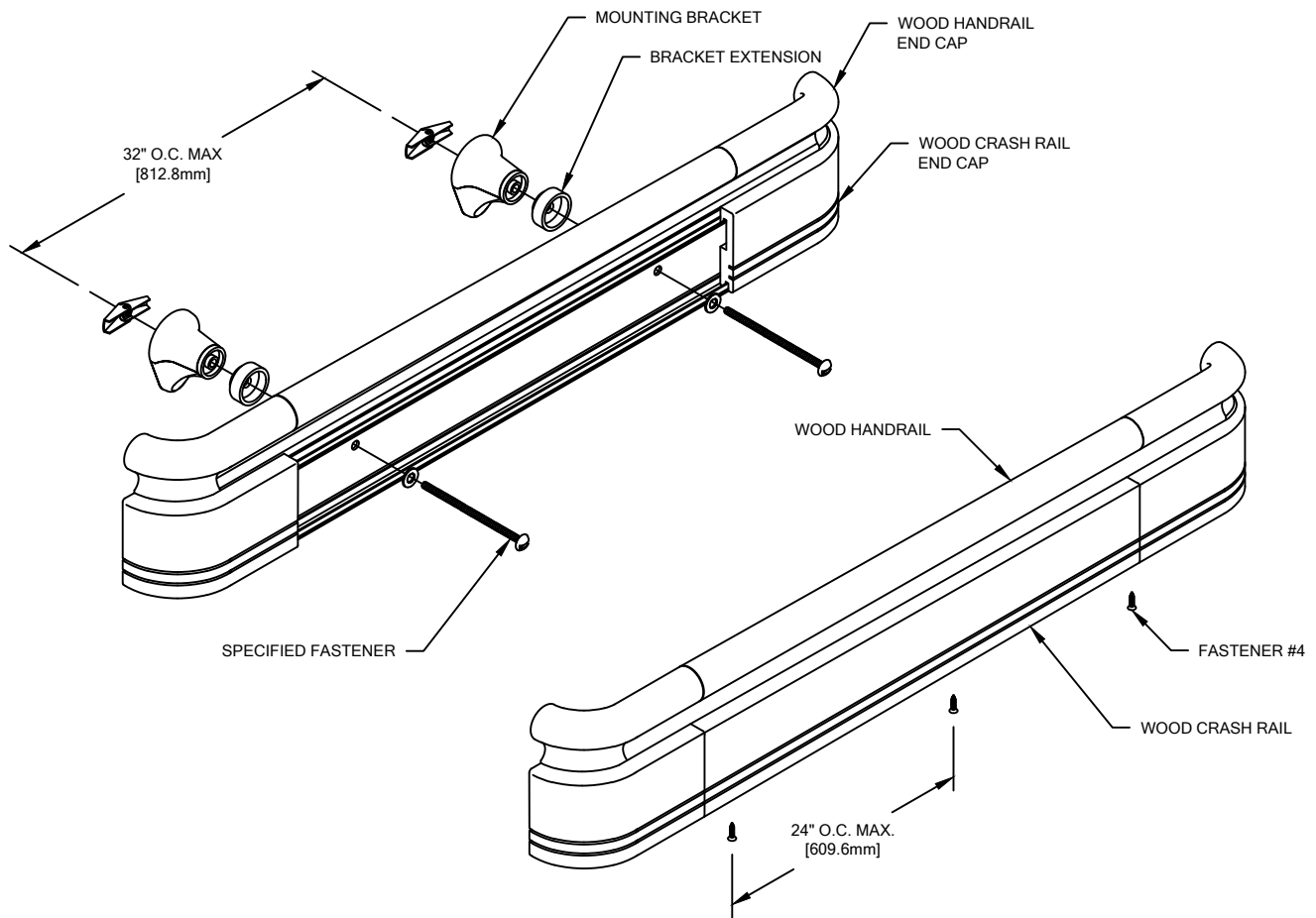

REVEAL INSTALLATION

END CAPS

1. LOOSEN THE #6 x 3/8" PHILLIPS PAN HEAD SHEET METAL SCREWS THAT HOLD THE END CAP REVEAL ADAPTER TO THE END CAP.
2. SLIDE THE END CAP REVEAL OVER THE INSTALLED END CAP ADAPTER. BE SURE TO PLACE THE LONG LEG OF THE REVEAL AT THE TOP.
3. TIGHTEN THE (3) THREE #6 x 3/8" PHILLIPS PAN HEAD SHEET METAL SCREWS

HANDRAIL

1. CUT ACCENT REVEAL TO LENGTH AND INSERT INTO SLOT PROVIDED IN THE TOP SECTION OF THE ALUMINUM RETAINER ON TOP OF PREVIOUSLY INSTALLED STANDARD REVEAL.