

HRB-10CN HANDRAIL

PLEASE READ

PLEASE READ THESE INSTRUCTIONS THOROUGHLY PRIOR TO BEGINNING THE HRB-10CN HANDRAIL INSTALLATION!

THIS INSTRUCTION SHEET IS INTENDED TO PROVIDE A SPECIFIC GUIDE TO FOLLOW FOR THE INSTALLATION OF THIS HRB-10CN HANDRAIL. CONTAINED WITHIN IS THE TECHNICAL INFORMATION AND INSTALLATION TECHNIQUES REQUIRED TO COMPLETE AN EFFICIENT, NEAT AND LONG-LASTING INSTALLATION.

INSPECT ALL MATERIALS FOR DAMAGE OR MISSING PARTS. IF YOU DISCOVER DAMAGED OR MISSING MATERIALS, IN THE USA PLEASE NOTIFY THE FACTORY AT (800) 233-8493, AND IN CANADA (888) 895-8955 FOR CUSTOMER SERVICE.

HRB-10CN HANDRAIL MUST BE INSTALLED IN ACCORDANCE WITH THESE INSTRUCTIONS! FAILURE TO FOLLOW THESE INSTRUCTIONS MAY VOID ANY PRODUCT WARRANTIES AND RESULT IN AN UNSUCCESSFUL INSTALLATION. FOR SPECIFIC QUESTIONS REGARDING THE INSTALLATION OF THIS HRB-10CN HANDRAIL PLEASE CALL THE FACTORY IN THE USA AT (800) 233-8493 OR EMAIL IWPTECHSUPPORT@C-SGROUP.COM. IN CANADA CALL (888) 895-8955 .

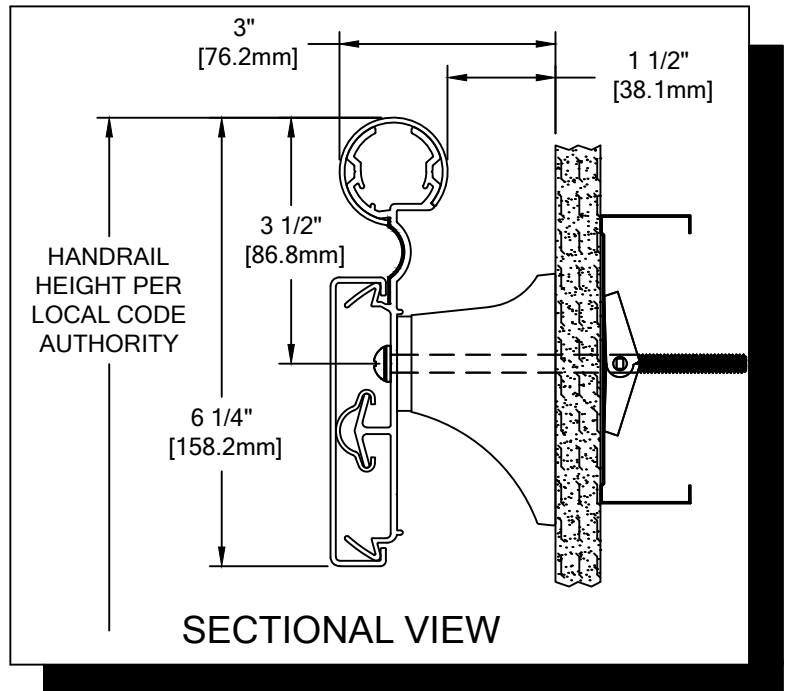

IMPORTANT NOTES

1. ALL LINEAL MATERIAL TO BE SUPPLIED IN STOCK LENGTHS. ALUMINUM AND ACROVYN IN LENGTHS UP TO 20'-0". THIS MATERIAL IS TO BE FIELD CUT USING QUALITY EQUIPMENT TO INSURE THAT ALL CUTS ARE SQUARE. WHEN CUTTING MATERIAL SECTIONS, C/S RECOMMENDS USING AN 80-100 TOOTH CARBIDE TIPPED SAW BLADE OR EQUIVALENT, TO MINIMIZE CHIPPING AND MAINTAIN JOINT ALIGNMENT.
2. RADIAL MATERIAL MAY BE SUPPLIED FACTORY FORMED OR IN STRAIGHT LENGTHS FOR FIELD FORMING. CONSULT FACTORY FOR OPTIONS.
3. ALL DIMENSIONS ARE TYPICAL.
4. FOR DRYWALL/PLASTER WALL CONSTRUCTION, IT IS RECOMMENDED FOR FASTENERS TO BE ENGAGED INTO METAL/WOOD STUDS TO MAINTAIN MAXIMUM PULLOUT STRENGTH. IF DURING INSTALLATION YOU ENCOUNTER SPECIAL WALL CONDITIONS THAT DO NOT ALLOW FOR DIRECT ATTACHMENT TO THE STUDS PLEASE CONSULT THE LOCAL AUTHORITY HAVING JURISDICTION.
5. INSTALL OUTSIDE CORNERS FIRST.
6. INSTALL LONGEST RUN OF HANDRAIL FIRST.
7. ALUMINUM RETAINER SPLICES SHOULD NOT EXCEED 3" [76.2mm] DISTANCE FROM A BRACKET.
8. THE DISTANCE BETWEEN AN ACROVYN SPLICE JOINT AND AN ALUMINUM RETAINER SPLICE JOINT SHOULD BE STAGGERED 4" [101.6mm].
9. TANGENT POINTS ON FACTORY FORMED RADIAL MATERIAL WILL BE MARKED APPROXIMATELY AND SHOULD BE CUT TO SUIT FIELD CONDITIONS.
10. MATERIAL MUST REACH 65°F MIN. TO 75°F MAX. 24 HOURS PRIOR TO INSTALLATION. THIS IS ESSENTIAL TO MINIMIZE EXPANSION AND CONTRACTION OF MATERIAL.
11. MAY REQUIRE USE OF FIRE PUTTY WHEN INSTALLED ON FIRE WALL WITH TOGGLE BOLTS. REFERENCE INSTRUCTIONS 24FIREPUTTY FOR FIRE PUTTY INSTALLATION.
12. THIS HANDRAIL REQUIRES A MINIMUM OF 2 MOUNTING BRACKETS PER UNIT. THE MINIMUM END CAP-TO-END CAP HANDRAIL LENGTH IS 13" [330.2mm].
13. FOR MORE INFORMATION ON HRB-10CN HANDRAIL SEE OUR WEBSITE AT www.c-sgroup.com.

HRB-10CN HANDRAIL

COMPONENTS & WALL FASTENERS



ACROVYN HANDRAIL COVER
(24U032xxx)
ACROVYN CHAMELEON COVER
(24U610xxx)



RC-10 CUSHION
(24U952108)



ALUMINUM RETAINER
(24A354000)

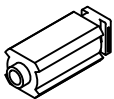

ALIGNMENT PLUG
(24I051000)



ACROVYN CRASH RAIL COVER
(24U009xxx)
ACROVYN CHAMELEON COVER
(24U616xxx)



ACROVYN ACCENT
REVEAL
(24N021xxx)

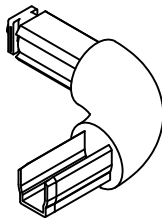

HANDRAIL OUTSIDE
CORNER ASSEMBLY



CRASH RAIL END CAP
ASSEMBLY
(RIGHT-HAND SHOWN)
(LEFT-HAND AVAILABLE)

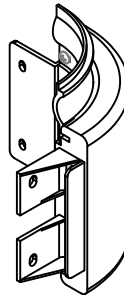

CRASH RAIL OUTSIDE
CORNER ASSEMBLY

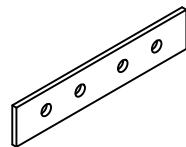

RETAINER SPLICE BAR
(24I976000)

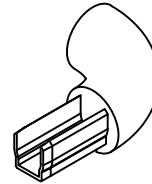

HANDRAIL END CAP
(24I083xxx, RH SHOWN)
(24I082xxx, LH)
CHAMELEON END CAP
(24I634xxx, RH SHOWN)
(24I610xxx, LH)



MOUNTING BRACKET
(24I007xxx)



FASTENER #7
#10 HEX NUT
(90H368002)

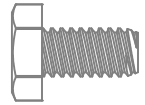

FASTENER #1
1/4-20 X 1/2" HEX
HEAD MACHINE SCREW
(90H052002)



FASTENER #2
1/4" LOCK WASHER
(90H006003)



FASTENER #3
1/4-20 HEX NUT
(90H010001)

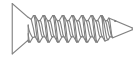

FASTENER #4
#6 X 5/8" PHILLIPS
FLAT HEAD SMS
(90H231002)

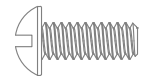

FASTENER #5
#10-24 X 1/2" ROUND HEAD
SLOTTED MACHINE SCREW
(90H369002)



FASTENER #6
#10 LOCK WASHER
(90H370002)

WALL CONDITION	SPECIFIED FASTENER	DRILL DIAMETERS		C/S PART NUMBER
		WALL	RETAINER	
STEEL STUD/GYPSUM WALL	1/4-20 X 5" ROUND HEAD BOLT WITH TOGGLE 1/4" LOCK WASHER	3/4"	9/32"	90H049002 90H006003
CONCRETE/CONCRETE BLOCK	#14 X 5" PHILLIPS RD HD ALL-PURPOSE SCREW	3/16"	9/32"	90H287002
WOOD STUD/GYPSUM WALL	#14 X 5" PHILLIPS RD HD ALL-PURPOSE SCREW	1/8"	9/32"	90H287002
20 GA. STEEL STUD/GYPSUM WALL (OSHDP)	1/4-20 X 5" RD. HD. BOLT WITH FLAT WASHER 1/4" TOGGLER WING 3M MOLDABLE FIRE PUTTY	1/2"	9/32"	90H659002 90H007003 90H062004 90M012000
16 GA. MIN. STEEL STUD AND 16 GA. MIN. STEEL STRAPPING / GYPSUM WALL CONSTRUCTION REQUIRED (TEK SCREWS)	#14 X 5" PHILLIPS PAN HEAD #3 SELF DRILLING TEK SCREW ZINC PLATED	N/A	9/32"	90H286001

HRB-10CN HANDRAIL

LAYOUT VIEW

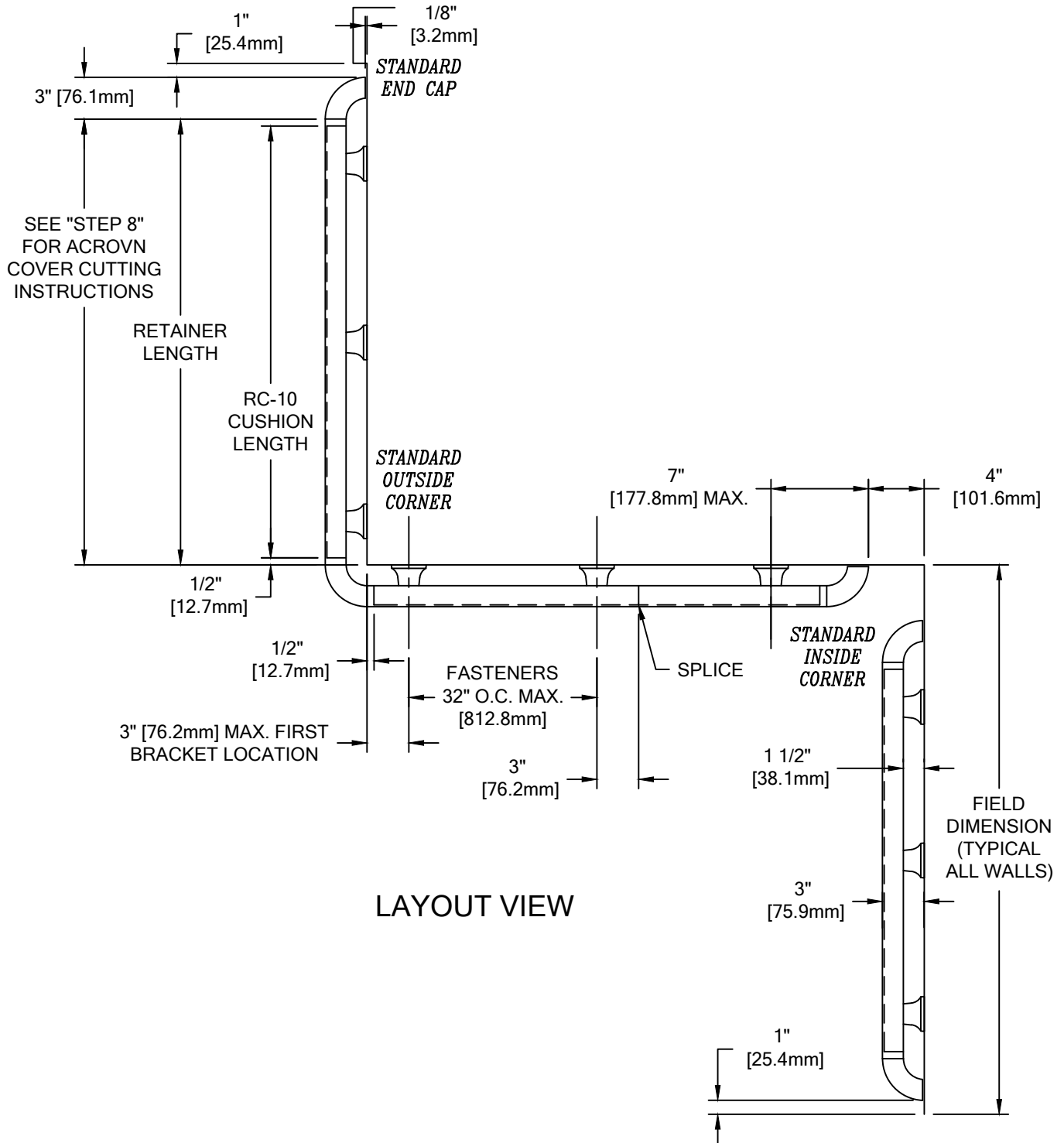

LAYOUT VIEW

HRB-10CN HANDRAIL

TYPICAL ASSEMBLY

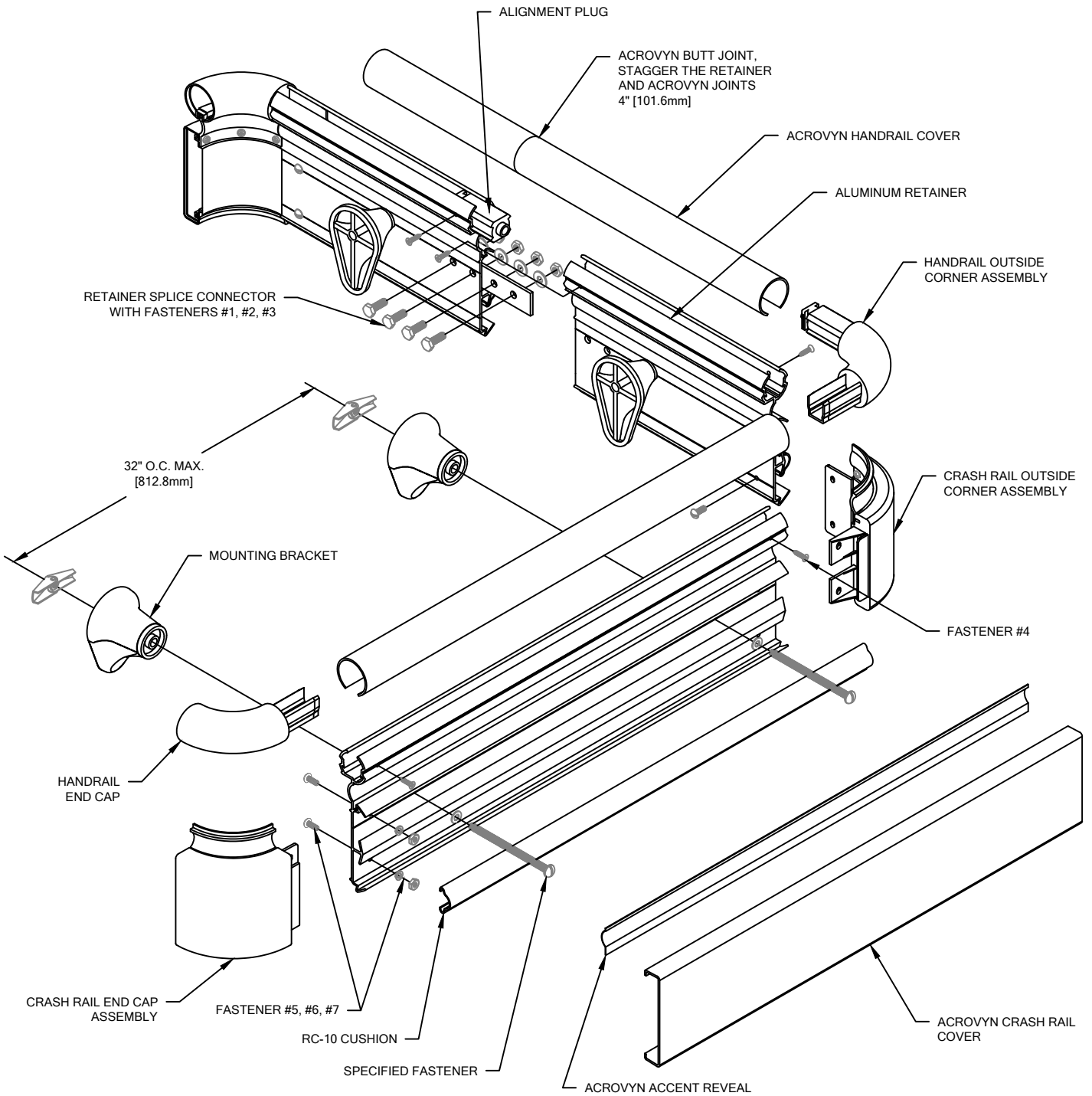

HRB-10CN HANDRAIL

TYPICAL ASSEMBLY

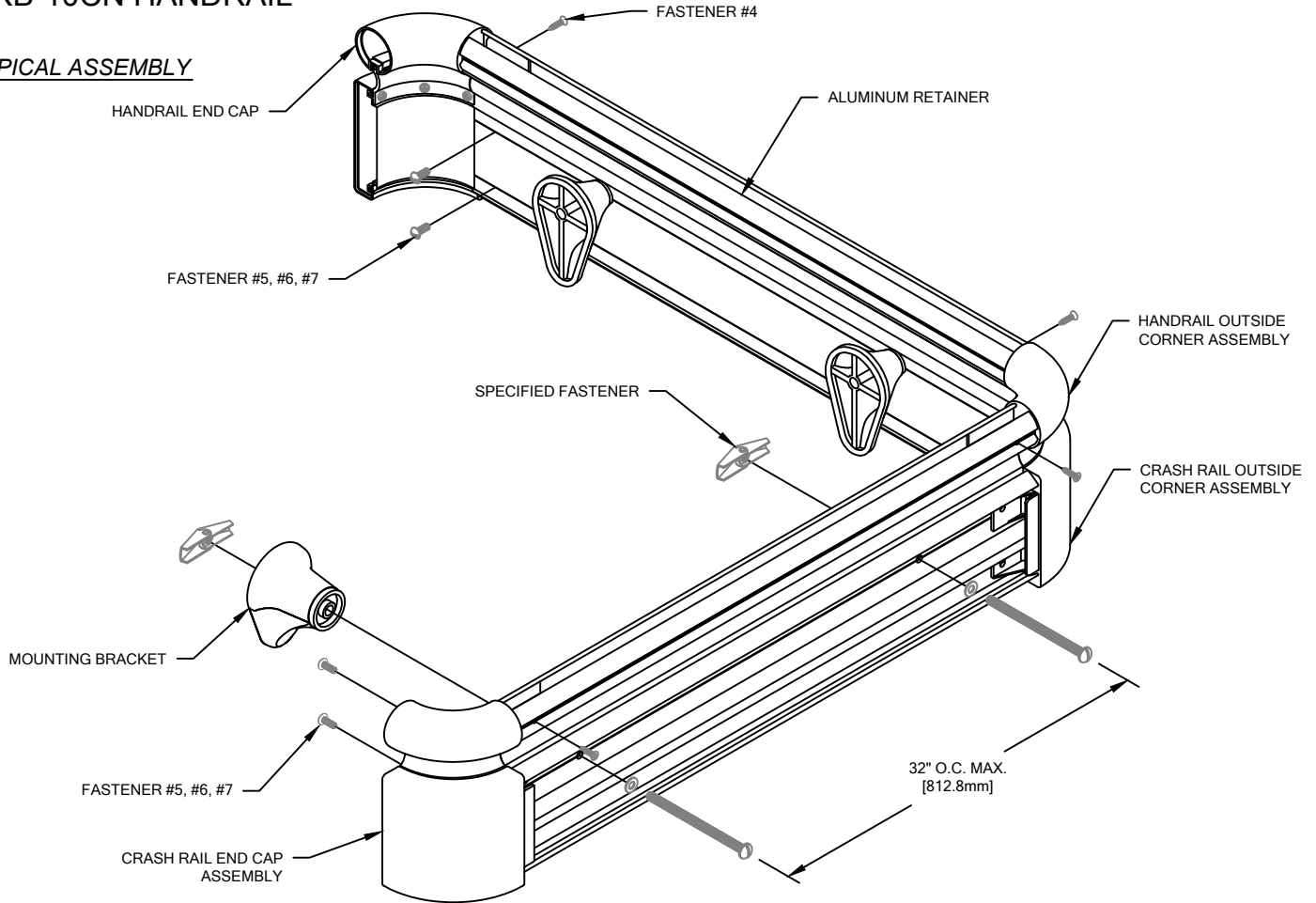

NOTE: INSTALLATION OF LINEAL OR RADIAL HRB-10CN HANDRAIL SHOULD BE DONE IN ACCORDANCE WITH THE FOLLOWING INSTRUCTIONS.

1. USING "LOCAL CODE" REQUIREMENTS, ESTABLISH HANDRAIL HEIGHT ABOVE FINISH FLOOR. DEDUCT 3 1/2" [88.9mm] AND SNAP A CHALK LINE AT THAT HEIGHT. THIS MARKS THE LOCATION OF THE HOLE FOR THE MOUNTING BRACKET FASTENER.
2. CUT THE CONTINUOUS ALUMINUM RETAINER TO LENGTH USING THE REQUIRED DEDUCTIONS (REFERENCE LAYOUT VIEW). PRE-DRILL CLEARANCE HOLES FOR THE SPECIFIED WALL FASTENERS IN THE ALUMINUM RETAINER 3" [76.2mm] FROM EACH END. REFERENCE CHART ON PAGE 2 FOR CORRECT DRILL DIAMETERS. ALL OTHER BRACKET HOLES MUST NOT EXCEED 32" [812.8mm] ON CENTER.

NOTE: IT IS RECOMMENDED THAT THE ACROVYN COVER AND ALUMINUM RETAINER BE CUT WITH AN 80-100 TOOTH CARBIDE TIPPED SAW BLADE OR EQUIVALENT.

3. DRILL CLEARANCE HOLES IN WALL SURFACE FOR MOUNTING HARDWARE, USING THE RETAINER AS A TEMPLATE. REFERENCE CHART ON PAGE 2 FOR CORRECT DRILL DIAMETERS.
4. ATTACH ALL END CAPS/OUTSIDE CORNERS:
 - A. ATTACH HANDRAIL PORTION OF END CAP TO RETAINER:
 - DRILL 5/32" DIAMETER CLEARANCE HOLES IN RETAINER 3/4" [19.1mm] FROM END OF RETAINER.
 - INSERT THE END CAPS INTO THE RETAINER.
 - DRILL 3/32" DIAMETER PILOT HOLES INTO THE END CAP.
 - ATTACH END CAP TO RETAINER USING #6 x 5/8" PHILLIPS FLAT HEAD SHEET METAL SCREW.
 - B. ATTACH CRASH RAIL PORTION OF END CAP TO THE RETAINER:
 - USE END CAP AS TEMPLATE TO DRILL 7/32" PILOT HOLES IN RETAINER.
 - ATTACH END CAP/OUTSIDE CORNERS BY SLIDING THE END CAP ONTO THE END OF THE ALUMINUM RETAINER AND SECURING INTO POSITION USING TWO (2) #10-24 X 1/2" RD HD SLOTTED MACHINE SCREW WITH LOCK WASHER AND #10 HEX NUT AT EACH END CAP AND FOUR (4) AT EACH OUTSIDE CORNER.

NOTE: TO AID IN LOCATING THE END CAPS CORRECTLY, CUT A 4" [101.6mm] SECTION OF COVER FROM SCRAP AND SNAP IT ON THE RETAINER. LOCATE THE CAP SO IT ALIGNS FLUSH WITH THE TOP AND BOTTOM OF THE COVER.

5. INSTALL EACH SECTION OF ASSEMBLED RETAINER IN SUCCESSION USING THE WALL BRACKETS AND THE APPROPRIATE WALL FASTENERS. DO NOT OVER TORQUE THE FASTENERS.

NOTE: WHEN FIELD FORMING RADIUS HANDRAIL, BE SURE TO APPLY NEEDED PRESSURE FROM BRACKET TO BRACKET.

HRB-10CN HANDRAIL

TYPICAL ASSEMBLY

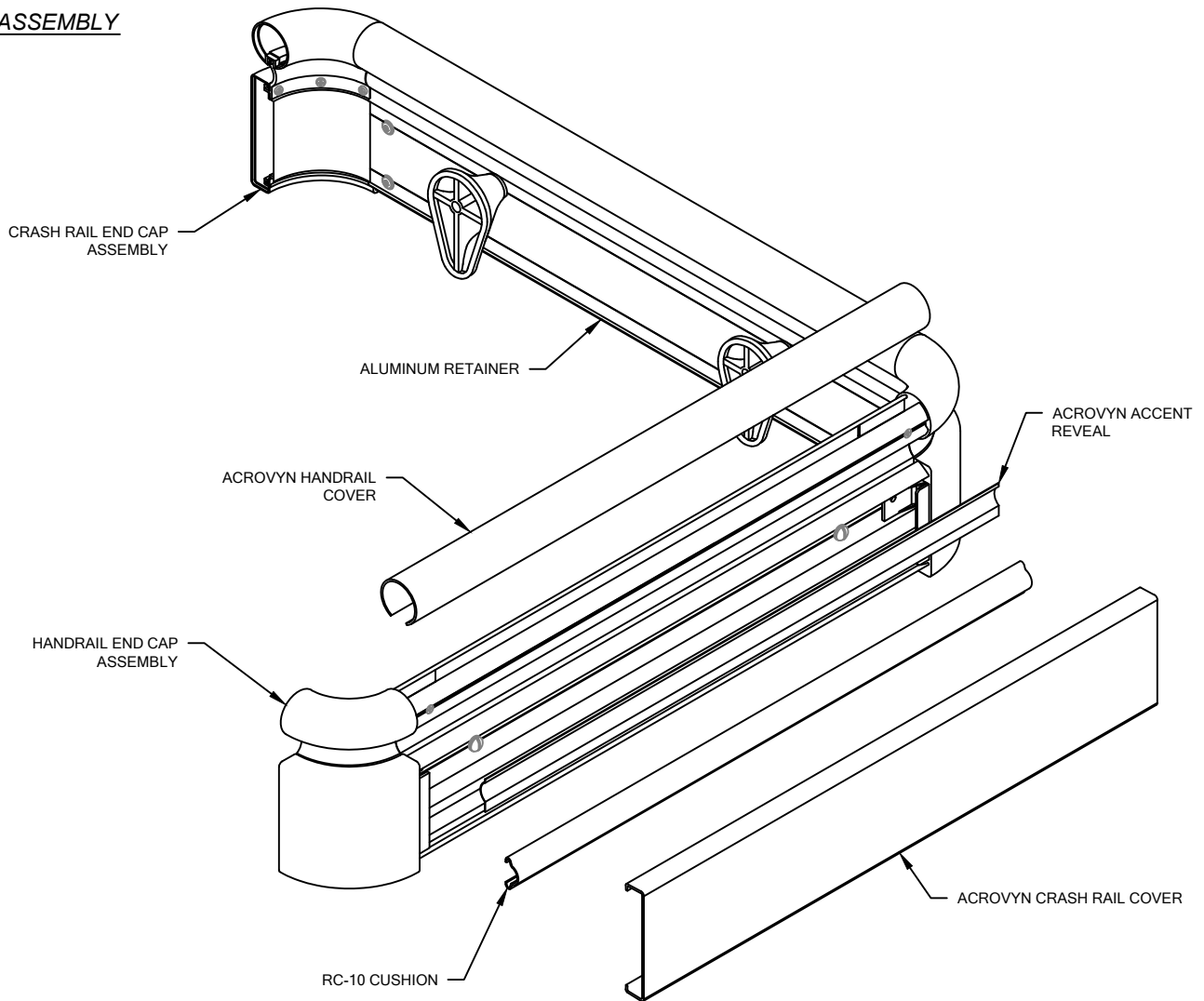

6. CUT RC-10 CUSHION TO LENGTH NOTING REQUIRED DEDUCTIONS (SEE LAYOUT VIEW) AND INSTALL ONTO ALUMINUM RETAINER.

7. CUT ACCENT REVEAL TO LENGTH AND INSERT INTO SLOT PROVIDED IN THE TOP SECTION OF THE ALUMINUM RETAINER.

NOTE: SEE PAGE 8 FOR CHAMELEON REVEAL INSTALLATION.

8. CUT ACROVYN HANDRAIL COVER AND ACROVYN CRASH RAIL TO LENGTH. THE COVER LENGTH IS DETERMINED BY MEASURING THE DISTANCE BETWEEN THE INSTALLED END CAPS AND/OR OUTSIDE CORNER ASSEMBLIES.

NOTE: IT IS RECOMMENDED THAT THE ACROVYN COVERS BE CUT SLIGHTLY LONGER (1/32" UP TO 5'-0", 1/16" OVER 5'-0") THAN THE MEASURED DISTANCE. THIS ADDITIONAL LENGTH WILL PROVIDE FOR A TIGHTER COVER-TO-END CAP FIT.

9. STARTING AT ONE END, SNAP THE HANDRAIL COVER ONTO THE RETAINER ALONG THE LENGTH OF THE HANDRAIL.

10. COMPLETE INSTALLATION BY INSTALLING THE ACROVYN COVER ONTO THE LOWER PORTION OF THE RETAINER.

NOTE: MANUFACTURER RECOMMENDS ALL PRINTED "PRODUCT IDENTIFICATION" ON THE REAR OF THE ACROVYN PROFILE SHALL BE ORIENTED IN THE SAME DIRECTION DURING INSTALLATION TO ENSURE PROPER ALIGNMENT AT SPLICE BUTT JOINTS.

HRB-10CN HANDRAIL

OUTSIDE CORNER ASSEMBLY

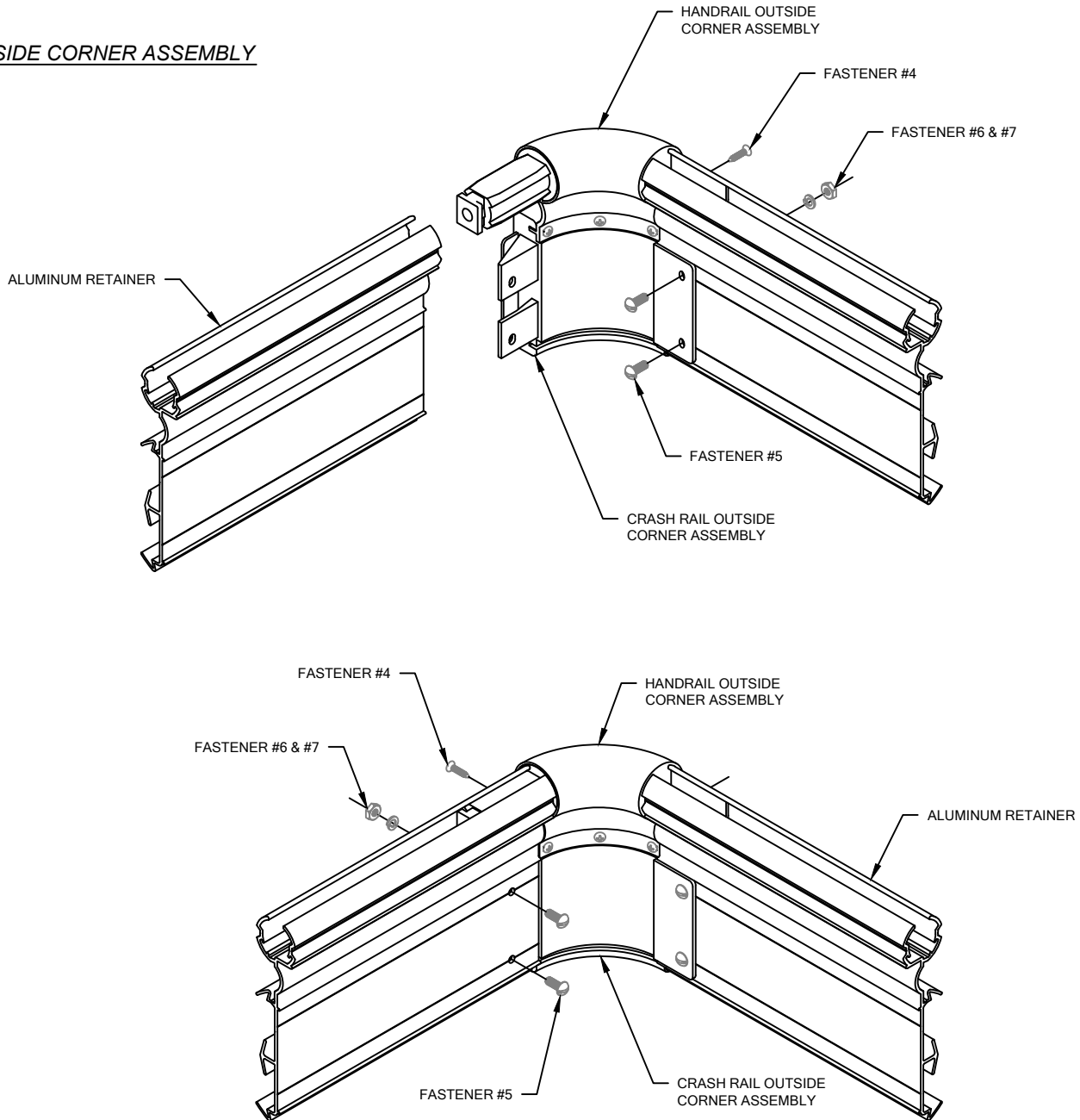

OUTSIDE CORNER INSTALLATION

1. ATTACH ALL OUTSIDE CORNERS:
 - A. ATTACH HANDRAIL PORTION OF OUTSIDE CORNER TO RETAINER:
 - DRILL 5/32" DIAMETER CLEARANCE HOLES IN RETAINER 3/4" [19.1mm] FROM END OF RETAINER.
 - INSERT THE OUTSIDE CORNERS INTO THE RETAINER.
 - DRILL 3/32" DIAMETER PILOT HOLES INTO THE END CAP.
 - ATTACH OUTSIDE CORNER TO RETAINER USING #6 x 5/8" PHILLIPS FLAT HEAD SHEET METAL SCREW.
 - B. ATTACH CRASH RAIL PORTION OF OUTSIDE CORNER TO THE RETAINER:
 - USE OUTSIDE CORNER AS TEMPLATE TO DRILL 7/32" PILOT HOLES IN RETAINER.
 - ATTACH OUTSIDE CORNERS BY SLIDING THE CORNER ONTO THE END OF THE ALUMINUM RETAINER AND SECURING INTO POSITION USING FOUR (4) #10-24 X 1/2" RD HD SLOTTED MACHINE SCREW WITH LOCK WASHER AND #10 HEX NUT AT EACH OUTSIDE CORNER.

NOTE: TO AID IN LOCATING THE OUTSIDE CORNERS CORRECTLY, CUT A 4" [101.6mm] SECTION OF COVER FROM SCRAP AND SNAP IT ON THE RETAINER. LOCATE THE CORNER SO IT ALIGNS FLUSH WITH THE TOP AND BOTTOM OF THE COVER.

NOTE: SOLID PORTION OF OUTSIDE CORNER FLANGE MOUNTS TO THE BACK OF THE RETAINER WHILE THE SPLIT FLANGE MOUNTS TO THE INSIDE OF THE RETAINER. SEE ILLUSTRATION ABOVE.

HRB-10CN HANDRAIL

CHAMELEON REVEAL ASSEMBLY

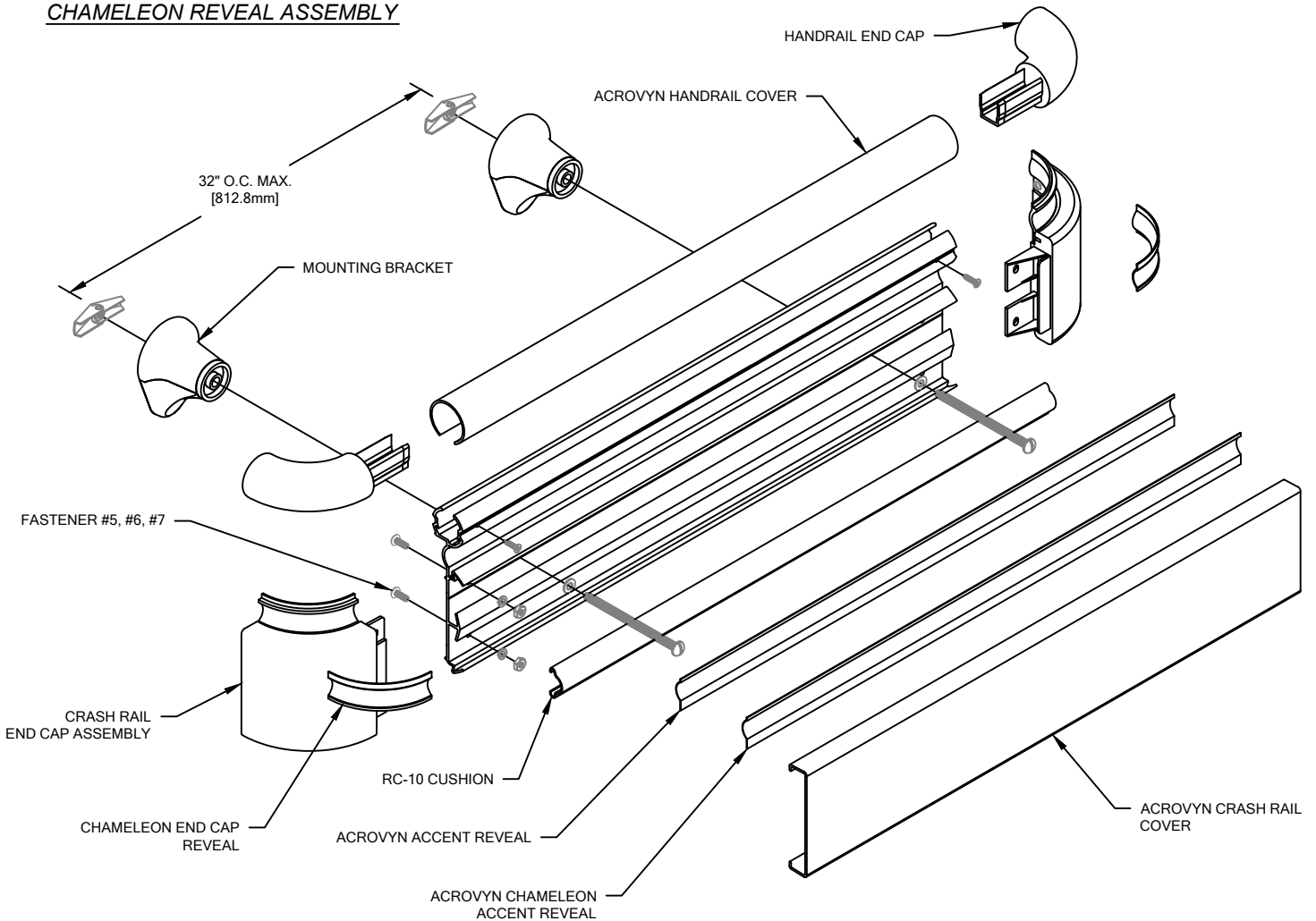

CHAMELEON REVEAL INSTALLATION

END CAPS

1. LOOSEN THE #6 x 3/8" PHILLIPS PAN HEAD SHEET METAL SCREWS THAT HOLD THE END CAP REVEAL ADAPTER TO THE END CAP.
2. SLIDE THE CHAMELEON END CAP REVEAL OVER THE INSTALLED END CAP ADAPTER. BE SURE TO PLACE THE LONG LEG OF THE CHAMELEON REVEAL AT THE TOP.
3. TIGHTEN THE (3) THREE #6 x 3/8" PHILLIPS PAN HEAD SHEET METAL SCREWS

HANDRAIL

1. CUT CHAMELEON ACCENT REVEAL TO LENGTH AND INSERT INTO SLOT PROVIDED IN THE TOP SECTION OF THE ALUMINUM RETAINER ON TOP OF PREVIOUSLY INSTALLED STANDARD REVEAL.

