

1-1/8" STAINLESS STEEL GRIDLINE 2 (STRAIGHT RAILS) SLIPNOT INSERTS RECESSED DEEP PIT FRAME

INSERT STYLE: N/A

INSERT COLOR: N/A

CATALOG NUMBER: G6

PART NUMBER:

NO.	REVISION	DATE	BY
NO.	F&F RELEASE	DATE	BY



SLIPNOT INSERT WIDTH OPTIONS

1/8" X 1-1/4" X 1-1/4" HOLD-DOWN PLATE 36" TO 48" O.C. SLOT SHOULD RUN PARALLEL TO SUPPORTS ALL FACING SAME DIRECTION.

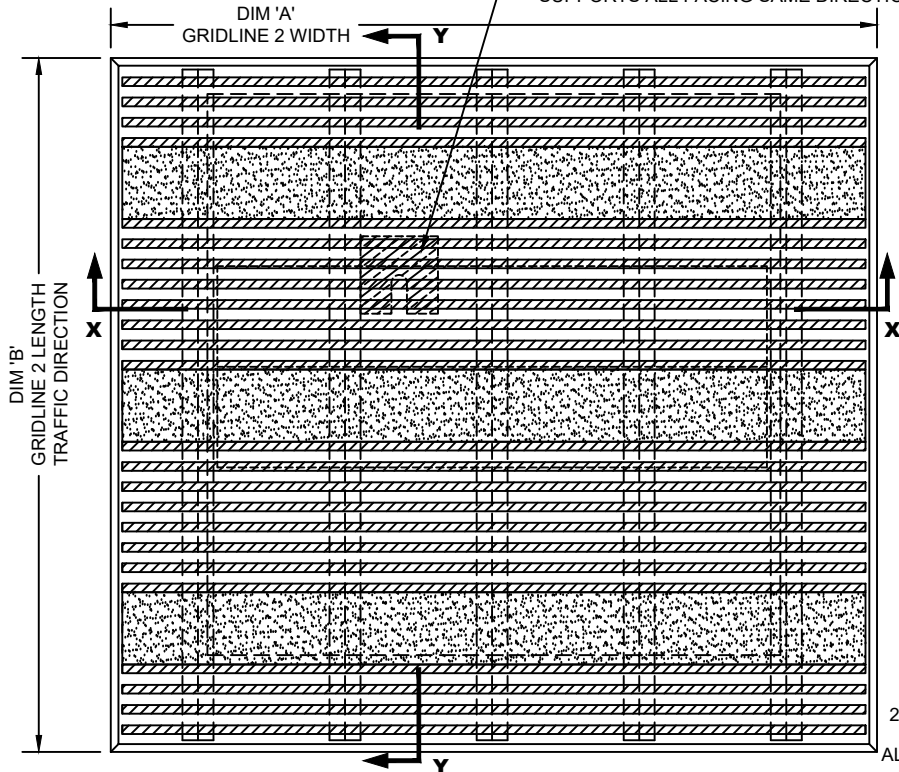

TYPICAL PLAN VIEW

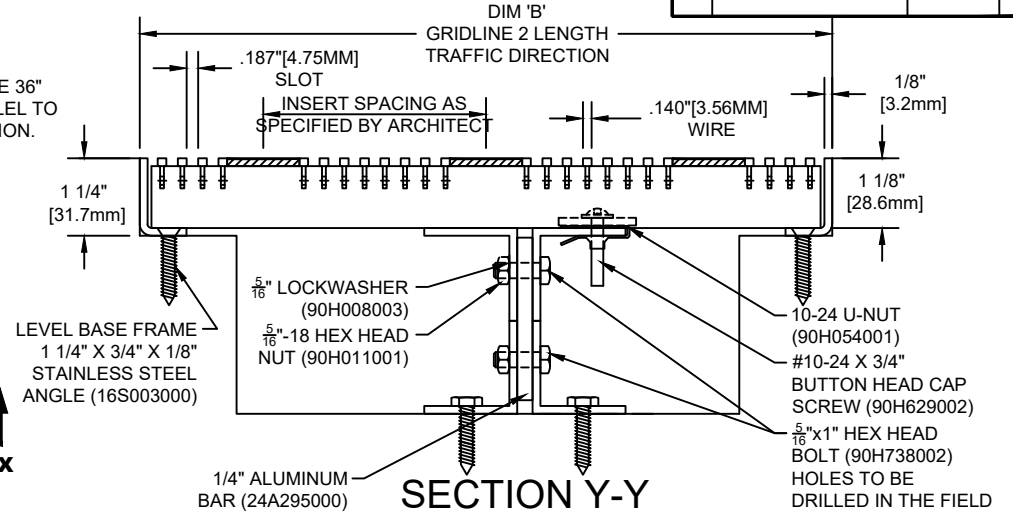

SECTION Y-Y

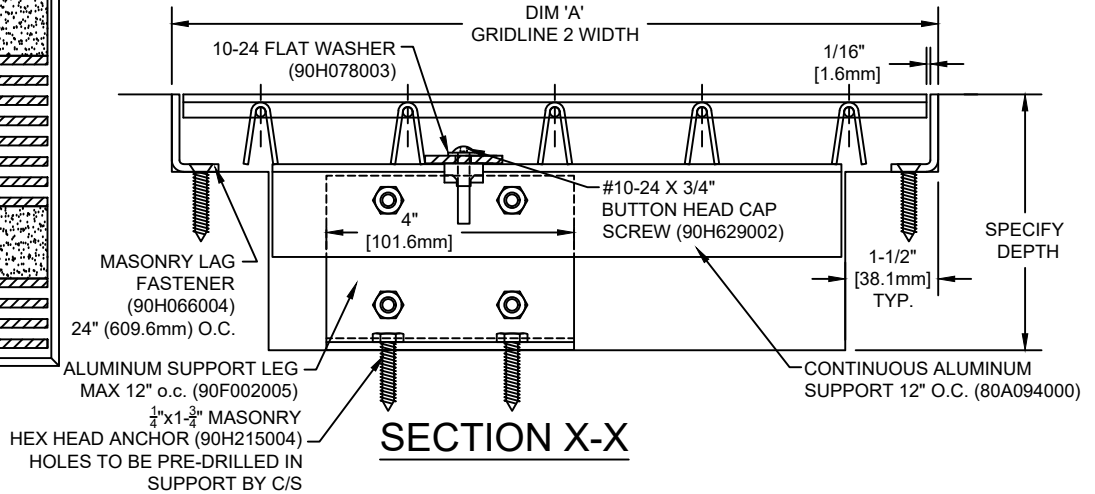

SECTION X-X

NOTES:

* MECHANICALLY INTELLOCKED DESIGN TO ENSURE CORRECT WEIGHT BEARING PROPERTIES.
 *MAX. SINGLE GRID SIZE NOT TO EXCEED 10'-0" [3.048M] IN WIDTH (DIM 'A') OR 6'-0" [1.829M] IN LENGTH (DIM 'B')

*GRIDS SHALL BE ABLE TO SUPPORT A 300LB/SQ.FT UNIFORM LOAD.
 * SURFACE WIRE SPACING PROVIDES A 57.7% EFFECTIVE OPEN AREA FOR DIRT AND MOISTURE REMOVAL.

CS Construction Specialties
 6696 Route 405 Highway, Muncy PA 17756
 (800) 233-8493 • Fax (570) 546-4692 • www.c-sgroup.com

QTY	MARK #	LOCATION	MODEL	DIM 'A' WIDTH	DIM 'B' LENGTH	FRAME FINISH	REMARKS

PROJECT:		
LOCATION:		
CONTRACTOR:		
AGENT:		SHT:
DRG. BY:	DATE:	JOB NO.:

PLEASE VERIFY ALL