

1-1/8" STAINLESS STEEL GRIDLINE 2 (STRAIGHT RAILS) WITH RECYCLED RUBBER INSERTS AND RECESSED LEVEL BASE FRAME / WITH ALUMINUM DRAIN PAN

INSERT STYLE: RECYCLED RUBBER      INSERT COLOR: PLEASE ADVISE      CATALOG NUMBER: G6      PART NUMBER:

NO.	REVISION	DATE	BY
NO.	F&F RELEASE	DATE	BY

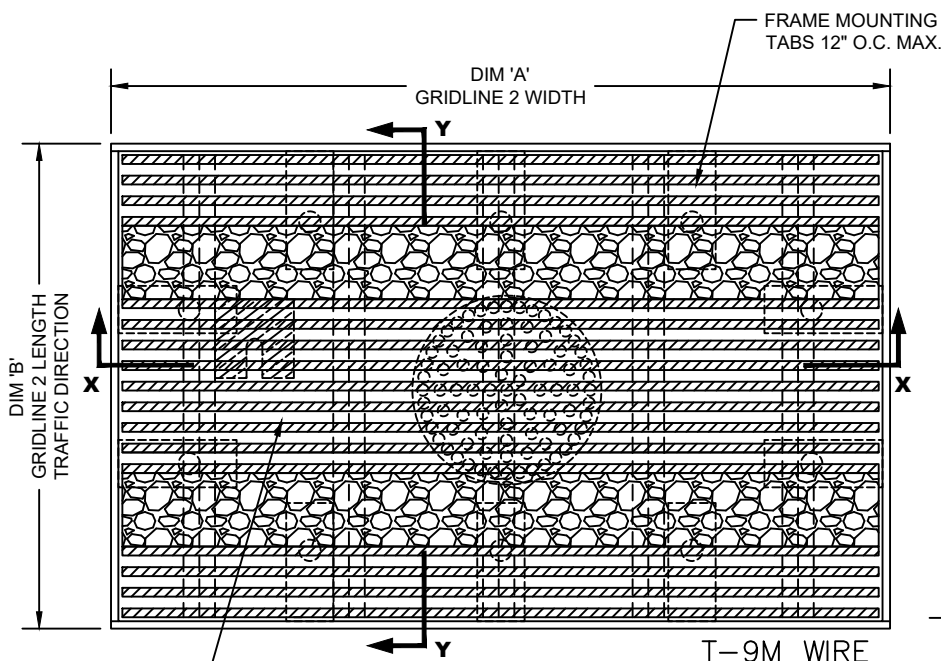

1/8" X 1-1/4" X 1-1/4" HOLD-DOWN PLATE 1 AT EACH CORNER STARTING ON INSIDE OF OUTER MOST SUPPORT THEN SPACE 36" TO 48" O.C. SLOT SHOULD RUN PARALLEL TO SUPPORTS ALL FACING SAME DIRECTION.

**TYPICAL PLAN VIEW**

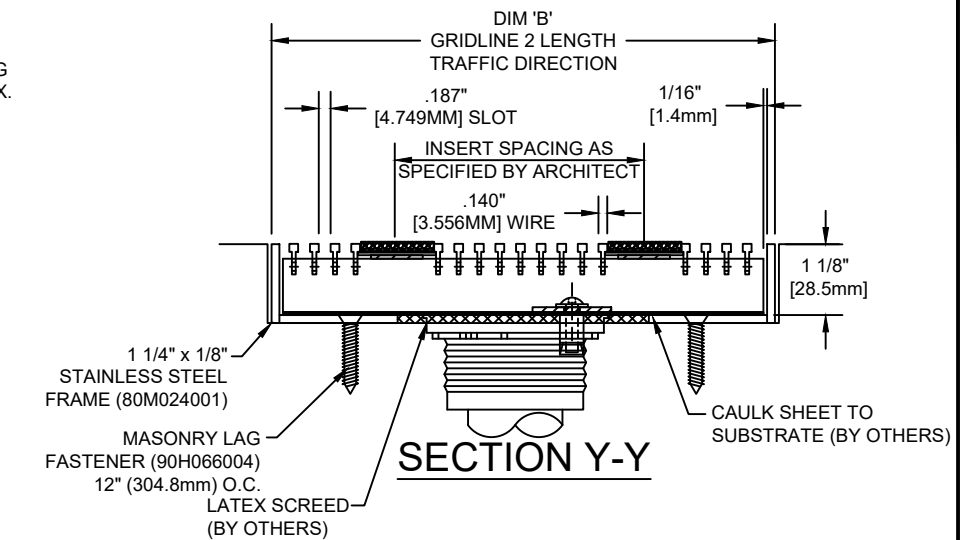

**SECTION Y-Y**

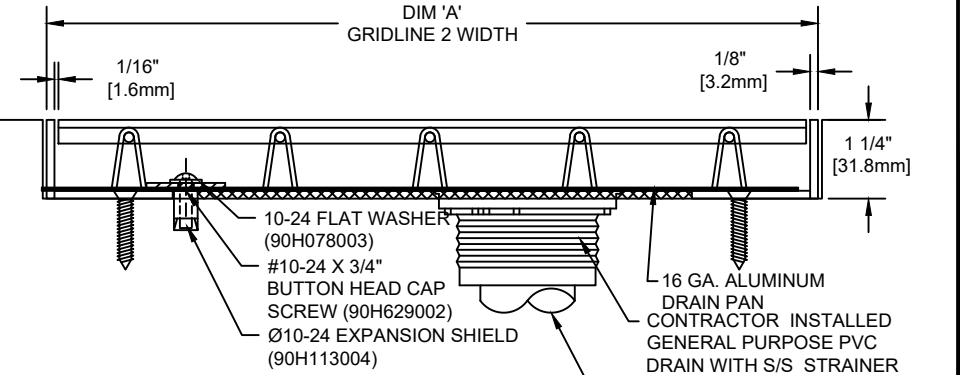

**SECTION X-X**

2" DRAIN PIPE (BY OTHERS)

**NOTES:**

- \* MECHANICALLY INTELLOCKED DESIGN TO ENSURE CORRECT WEIGHT BEARING PROPERTIES.
- \* MAX. SINGLE GRID SIZE NOT TO EXCEED 10'-0" [3.048M] IN WIDTH (DIM 'A') OR 6'-0" [1.829M] IN LENGTH (DIM 'B')
- \* GRIDS SHALL BE ABLE TO SUPPORT A 500LB ROLLING LOAD.
- \* SURFACE WIRE SPACING PROVIDES A 57.7% EFFECTIVE OPEN AREA FOR DIRT AND MOISTURE REMOVAL.

**CS Construction Specialties**  
 6696 Route 405 Highway, Muncy PA 17756  
 (800) 233-8493 • Fax (570) 546-4692 • www.c-sgroup.com

PLEASE VERIFY ALL	QTY	MARK #	LOCATION	MODEL	DIM 'A' WIDTH	DIM 'B' LENGTH	FRAME FINISH	REMARKS

PROJECT:		
LOCATION:		
CONTRACTOR:		
AGENT:		SHT:
DRG. BY:	DATE:	JOB NO.: