

1-1/8" STAINLESS STEEL GRIDLINE 2 (STRAIGHT RAILS) WITH NO FRAME

INSERT STYLE: N/A

INSERT COLOR: N/A

CATALOG NUMBER: G62

PART NUMBER:

NO.	REVISION	DATE	BY
NO.	F&F RELEASE	DATE	BY

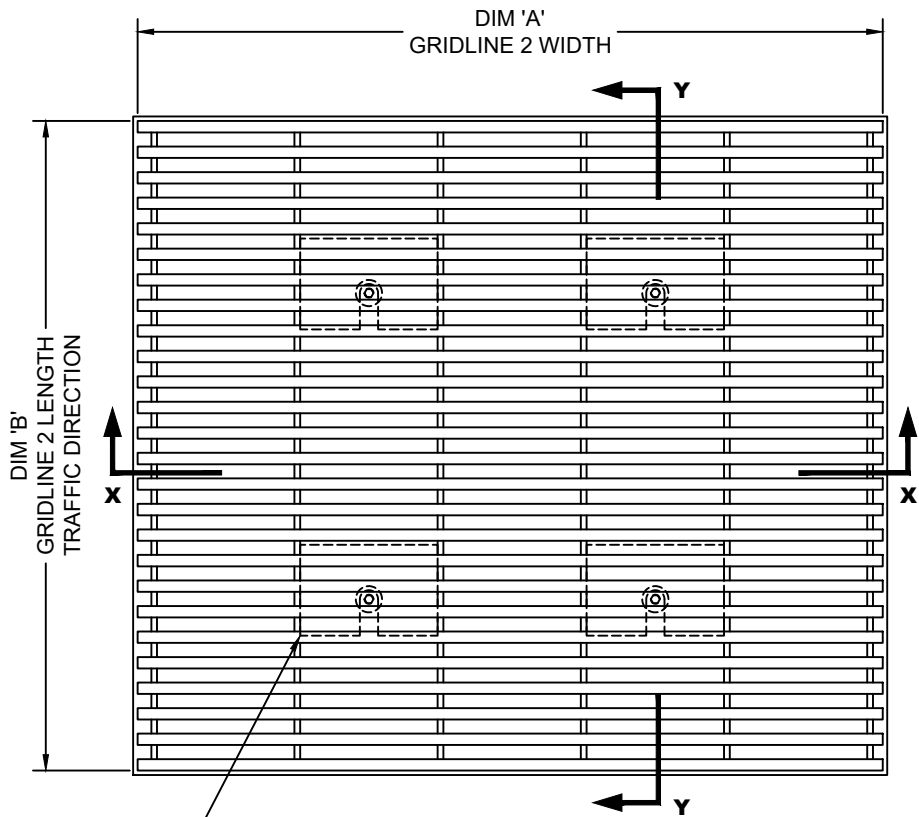

1/8" X 1-7/8" X 1-1/4" HOLD-DOWN PLATE 1 AT EACH CORNER THEN SPACE 30" O.C. SLOT SHOULD RUN PARALLEL TO SUPPORTS ALL FACING SAME DIRECTION (90F040001).

**TYPICAL PLAN VIEW**

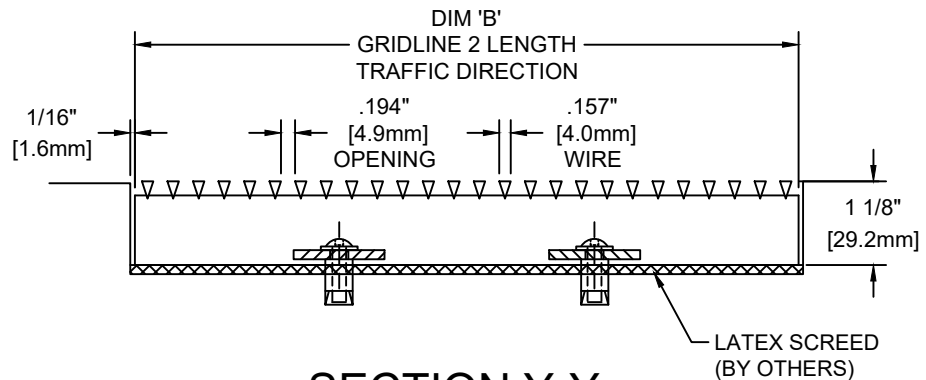

**SECTION Y-Y**

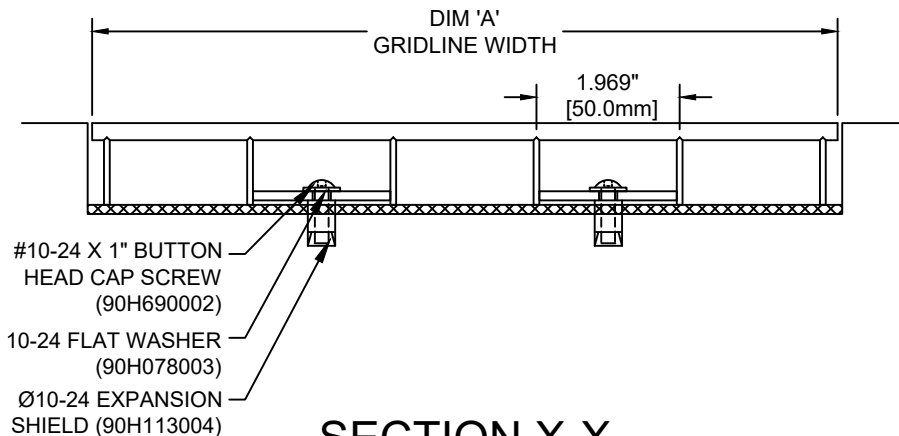

**SECTION X-X**

**NOTES:**

\*MAX. SINGLE GRID SIZE NOT TO EXCEED 95-1/4" [2.419M] IN WIDTH (DIM 'A') AND 49-1/16" [1.246M] IN LENGTH (DIM 'B')  
 \*ALL SURFACE WIRES AND SUPPORT BARS ARE ELECTRONICALLY RESISTANCE WELDED TO ENSURE CORRECT WEIGHT BEARING PROPERTIES.

\*GRIDS SHALL BE ABLE TO SUPPORT A 1000LB ROLLING LOAD.  
 \* SURFACE WIRE SPACING PROVIDES A 55.3% EFFECTIVE OPEN AREA FOR DIRT AND MOISTURE REMOVAL.  
 \*ADDITIONAL SPECIFICATIONS ARE CONTAINED IN THE LATEST C/S CATALOG OR AT C-SGROUP.COM AND ARE CONSIDERED PART OF THIS TRANSMITTAL.

**CS Construction Specialties™**  
 8696 Route 405 Highway, Muncy PA 17756  
 (800) 233-8493 • Fax (570) 546-4692 • www.c-sgroup.com

PLEASE VERIFY ALL	QTY	MARK #	LOCATION	MODEL	DIM 'A' WIDTH	DIM 'B' LENGTH	FRAME FINISH	REMARKS

PROJECT:		
LOCATION:		
CONTRACTOR:		
AGENT:		SHT:
DRG. BY:	DATE:	JOB NO.: