

**COLOR:**  
**HANDRAIL WOOD SPECIES:** \_\_\_\_\_  
**HANDRAIL WOOD FINISH:** \_\_\_\_\_  
**CRASH RAIL:** \_\_\_\_\_  
**\*MOUNTING BRACKET:** \_\_\_\_\_  
 COLOR TO BE SELECTED FROM ONE OF CS STANDARD COLORS.

\*MOUNTING BRACKET SUPPLIED IN STANDARD MILL FINISH. OPTIONAL CLEAR ANODIZED AND POWDER COAT FINISH AVAILABLE. PLEASE ADVISE POWDER COAT FINISH IF REQUIRED.

TOTAL L/F REQ'D	LEFT END CAPS	RIGHT END CAPS	O.S.C. REQ'D

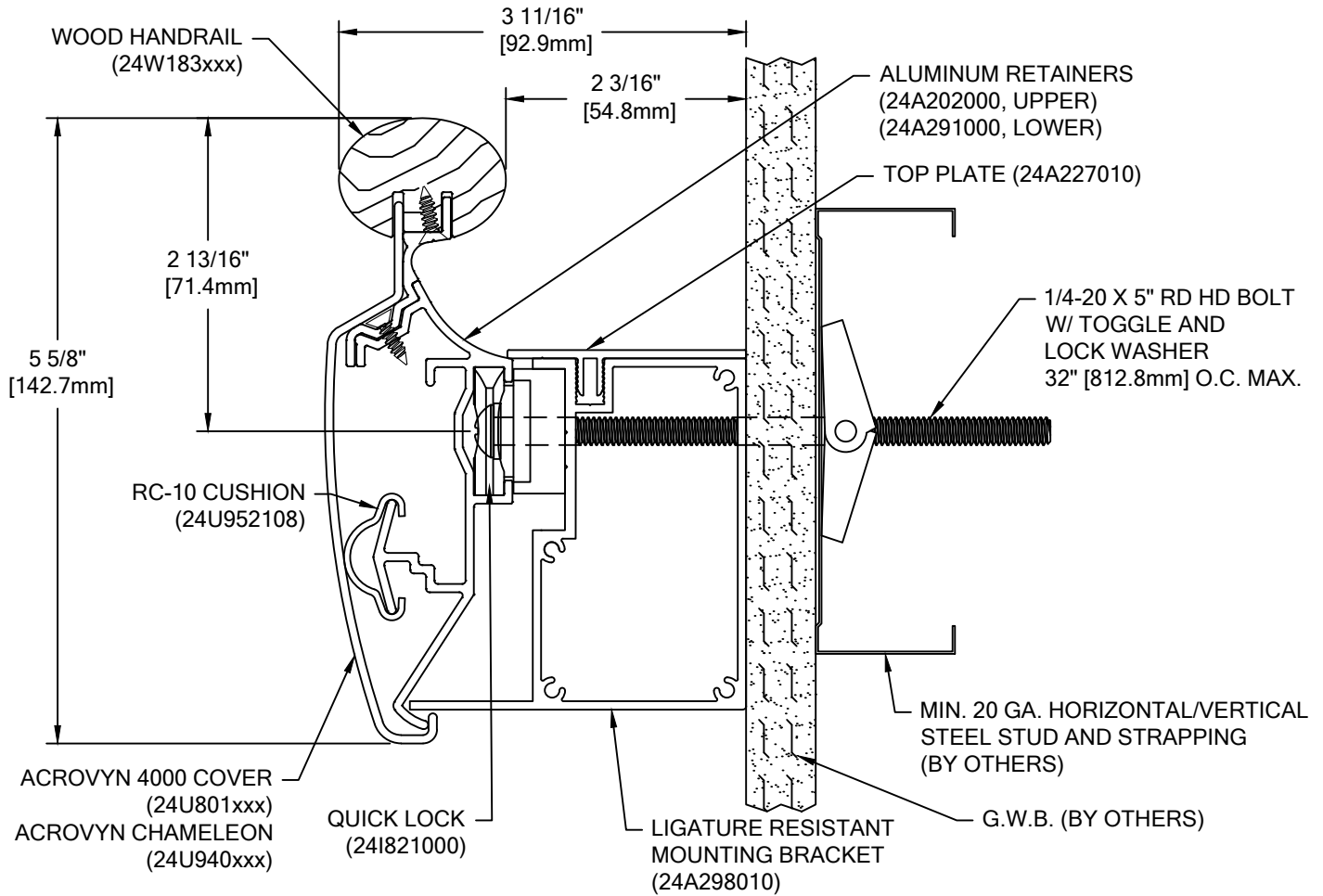

## HRBW-20CMN ACROVYN 4000 INTERNATIONAL OFFSET

WALL CONDITION	SPECIFIED FASTENER	DRILL DIAMETERS		CS PART NUMBER
		WALL	RETAINER	
STEEL STUD/GYPSUM WALL	1/4-20 X 5" ROUND HEAD BOLT WITH TOGGLE, AND LOCK WASHER	3/4"	N/A	90H049002 90H006003
CONCRETE/CONCRETE BLOCK	#14 X 5" S/S PHILLIPS RD HD ALL-PURPOSE SCREW	3/16"	N/A	90H287006
WOOD STUD/GYPSUM WALL	#14 X 5" S/S PHILLIPS RD HD ALL-PURPOSE SCREW	1/8"	N/A	90H287006

 Hughesville, PA   800.233.8493   570.546.5941 Mississauga, ON   888.895.8955   905.274.3611 <a href="http://www.c-sgroup.com">www.c-sgroup.com</a> © Copyright 2017 Construction Specialties, Inc.	<b>PROJECT:</b>	<b>REVISION:</b>
	<b>JOB NO.:</b>	<b>F&amp;F:</b>
	<b>CUSTOMER:</b>	
	<b>REP:</b>	<b>DATE:</b>
	<b>DRAWN BY:</b>	<b>SHEET NO:</b>