

# MODEL SSR 200 - 400 INSTALLATION INSTRUCTIONS

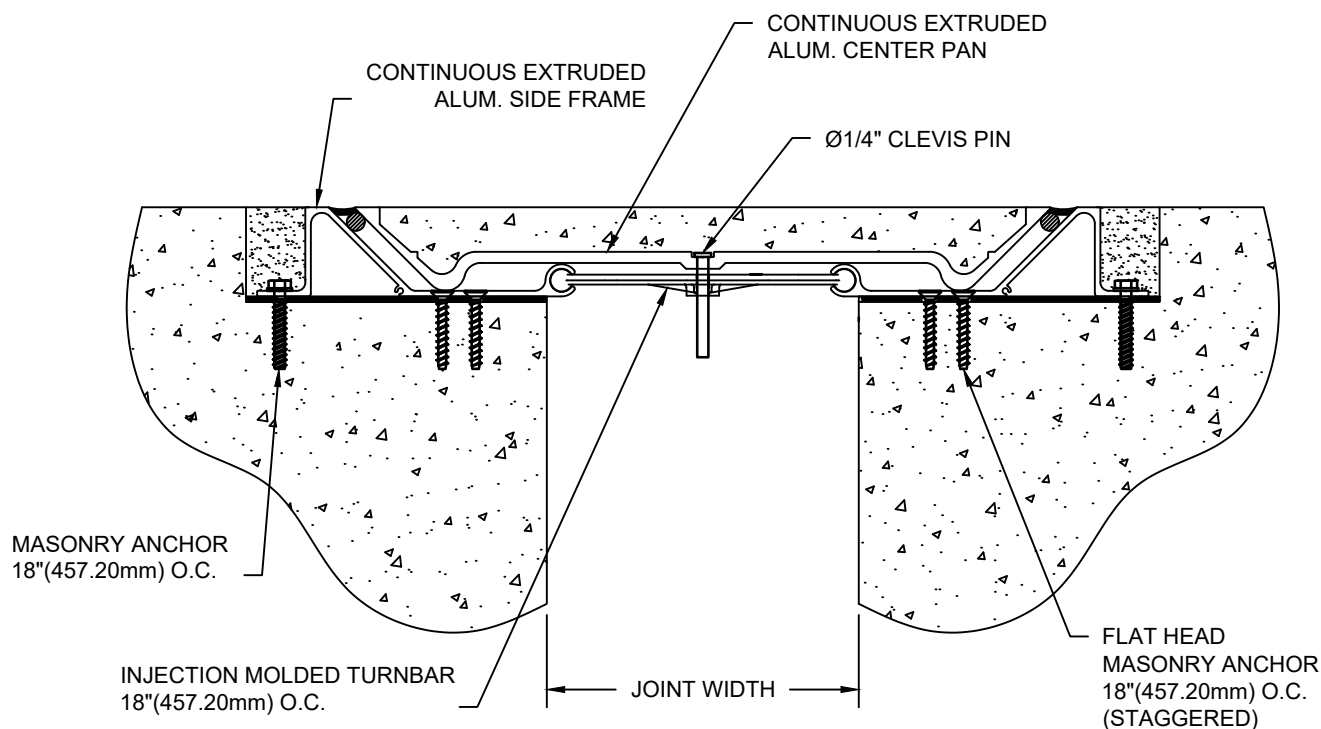

## IMPORTANT INFORMATION

Prior to the commencement of Installation, all materials **MUST** be inspected for Damage. Any damage must be reported to CONSTRUCTION SPECIALTIES, INC., as soon as possible, so that replacement materials may be furnished without delay.

All work must be completed as per Architect's Approved "Shop Drawings", and in accordance with these Installation Instructions. When installation is complete, all materials must be protected from damage until the Architect's FINAL INSPECTION.

All materials should be arranged in the order that they are to be installed. All hardware required for each portion of the work should be placed with the appropriate materials.

Please review all Approved Shop Drawings and this Document to familiarize yourself with all the details and components of this assembly.

### IMPORTANT:

**READ THROUGH ALL INSTRUCTIONS PRIOR TO STARTING INSTALLATION**

3/15/2021



**Construction Specialties™**

6696 Route 405 Highway, Muncy PA 17756  
(800) 233-8493 • Fax (570) 546-5169 • www.c-sgroup.com

This document is the property of Construction Specialties, Inc. and contains CONFIDENTIAL PROPRIETARY INFORMATION that is not to be disclosed to third parties and is not to be used without approval in writing from Construction Specialties, Inc.

Notes:

Before beginning installation, review the architectural drawings and approved Construction Specialties Inc. shop drawings to familiarize yourself with the appropriate joint cover models and locations.

Check all of the joint cover components to confirm that the correct joint cover model and size have been received. Also, check for materials that may have been damaged during shipping. Report all incorrect and/or damaged components to CS at 800-233-8493.

Read through all the steps of these instructions prior to beginning work.

**IMPORTANT: Concrete will curl the center-plate of this system unless you take proper measures to prevent it.**

**Selection of the proper concrete mix is essential. Talk to your local Concrete supply Engineer and discuss this special application and get their recommendation(s) for the mix that will prevent excessive curling of the center-plate/pan. (They know concrete, your local practices and weather conditions.)**

**Their recommendations may include a low water-to-cement ratio; changing the aggregate, adjusting the cement-to-fly ash ratio; longer cure time; controlling shrinkage with an admixture; moist curing, ect.**

**All such recommendations should be coordinated with the Architect to ensure the integrity of the specification is maintained.**

**EXTERIOR INSTALLATION of this expansion joint cover system requires yet more care and in addition to any/all of the above possible recommendations from your Concrete Engineer, moist curing has been found to be essential to a successful installation.**

# STEP 1

PREPARE BLOCKOUTS

BLOCKOUT DIMENSIONS	
DIM. A	DIM. B
2" [50.80mm]	7 $\frac{1}{4}$ " [184.15mm]
3" [76.20mm]	6 $\frac{3}{4}$ " [171.45mm]
4" [101.60mm]	6 $\frac{1}{4}$ " [158.75mm]

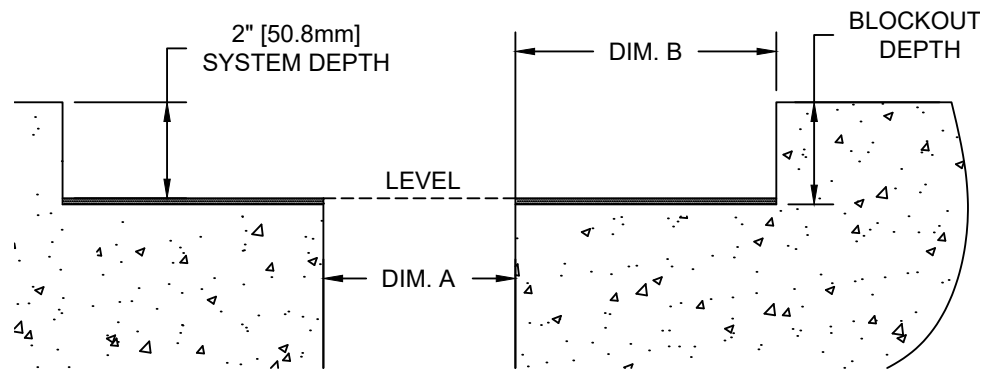

- 1.1) Before beginning installation of these joint covers, review the layouts for the various runs of joint cover as detailed on the approved CS shop drawings.
- 1.2) The "SSR" series joint covers must be securely mounted to structurally sound substrates. Repair all cracks or spawled areas of the concrete in the blockouts and in the deck adjacent to the blockout.
- 1.3) The blockouts in which the covers are to be mounted must be **flat, level and parallel**. The blockout depth should be made deeper than the actual system depth and self-leveling grout should be used to set the final depth, and to provide a smooth, flat finish. **The base of the blockout must be flat (along the length of the joint) to within +/-1/16" and level (across the joint) to within +/-1/16"**.
- 1.4) The blockout width shown on the CS shop drawings is a minimum width dimension. The blockout may be made wider to allow for greater installation tolerance.
- 1.5) The surface of the blockouts must be clean and free from any loose dirt, dust, debris and oils that would affect the installation of the covers. It is possible that the expansion/seismic joint may have experienced some amount of movement at the time of installation. For proper installation of the "SSR" covers, the joint width **must be within +/-1/4" of nominal**.
- 1.6) If the joint width at the time of installation is not within this tolerance, please contact the factory as some adjustments to the key installation dimensions may be required. These instructions assume that the nominal joint is within tolerance.
- 1.7) Coordinate installation of cover with installation of fire barrier systems and vapor barrier membrane when required.

# STEP 2

## SIDE FRAME INSTALLATION

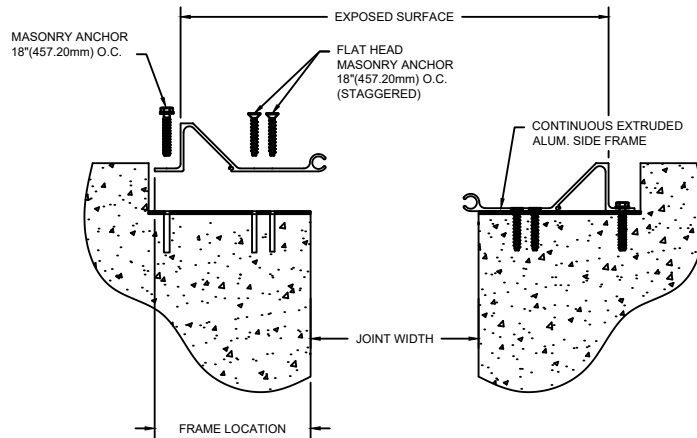

### Note:

If a CS Fire Barrier is to be installed in the joint, please review the Fire Barrier Installation Instructions supplied, and if required install the Fire Barrier **BEFORE** installation of CS Seismic Expansion Joint aluminum frames. If a vapor barrier is to be installed in the joint, please review the vapor barrier Installation Instructions supplied, and if required install the vapor barrier **BEFORE** installation of CS Seismic Expansion Joint Aluminum Frames.

### Note:

Proper installation of the "SSR" covers is dependent upon the proper location of the base frames. For the pan assembly to fit and function properly between the Frames, the Frames must be anchored parallel to the joint and to one another. They must be located at the proper distance from the edge of the joint and the exposed surface dimension must be maintained within a tolerance of  $\pm 1/8$ ". The exposed surface must also be centered over the joint to within  $\pm 1/8$ ".

- 2.1) The Frame Location, Exposed Surface and Joint Width dimensions are shown on the CS shop drawings.
- 2.2) In the blockout on the one side of the joint, measure and mark the bottom of the blockout at the frame location dimension. Strike a chalk line at this location, along the full length of the run.
- 2.3) Beginning near the center of the run and working towards each end, position the first length of Side Frame along the frame location line.
- 2.4) Using the Side Frame as a template, drill the holes for the supplied anchor bolts. (Follow the drilling instructions provided by the anchor bolt manufacturer.)
- 2.5) Remove the Side Frame and clean the holes. Reposition the Side Frame and anchor the Side Frame into the blockout with the supplied anchor bolts. (Follow the anchor bolt manufacturer's installation instructions.)

### Note:

To assist in maintaining the alignment of the exposed top edge of Base Frames, grooved alignment pins are to be placed in the Frame sections prior to installation.

- 2.6) Place one of the grooved alignment pins into the extrusion boss of the next length of Base Frame. Insert the pin approximately  $1/2$  of its length.
- 2.7) Repeat the installation procedure for the opposite side of the joint and any additional sections of Side Frame required to complete the run. However do NOT install the last sections of Side Frames until Step 3 is completed.

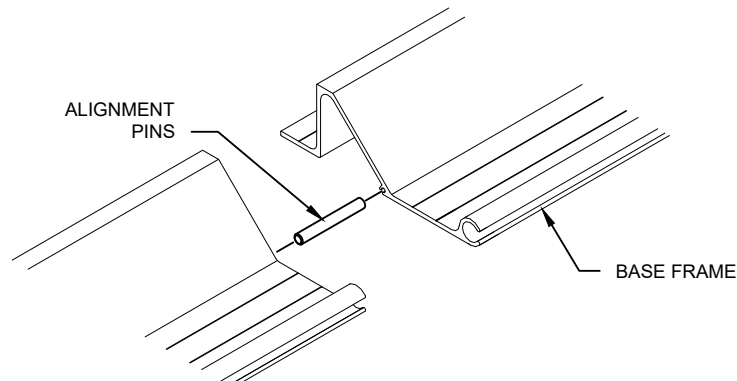

# STEP 3

## TURNBAR INSTALLATION

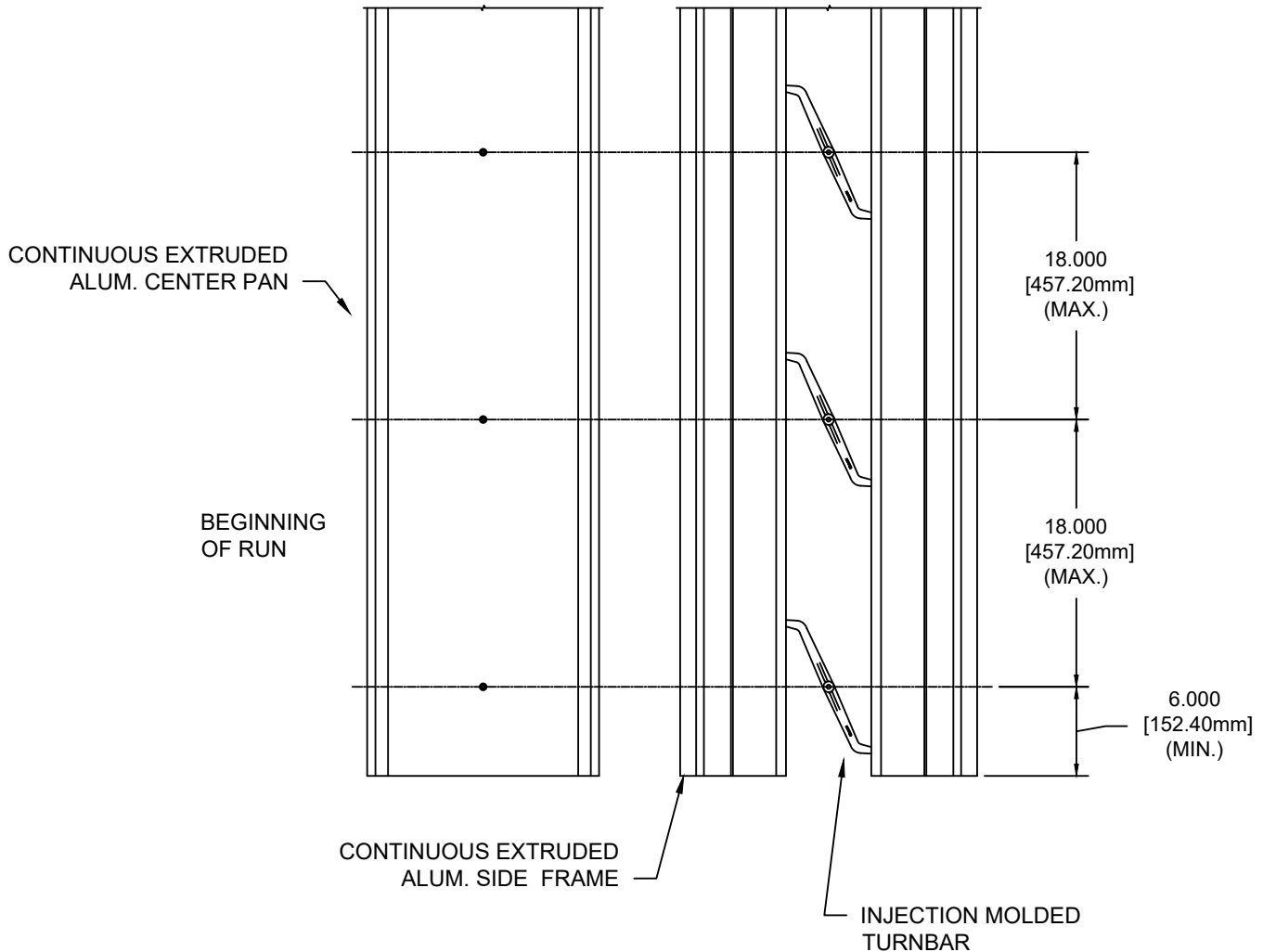
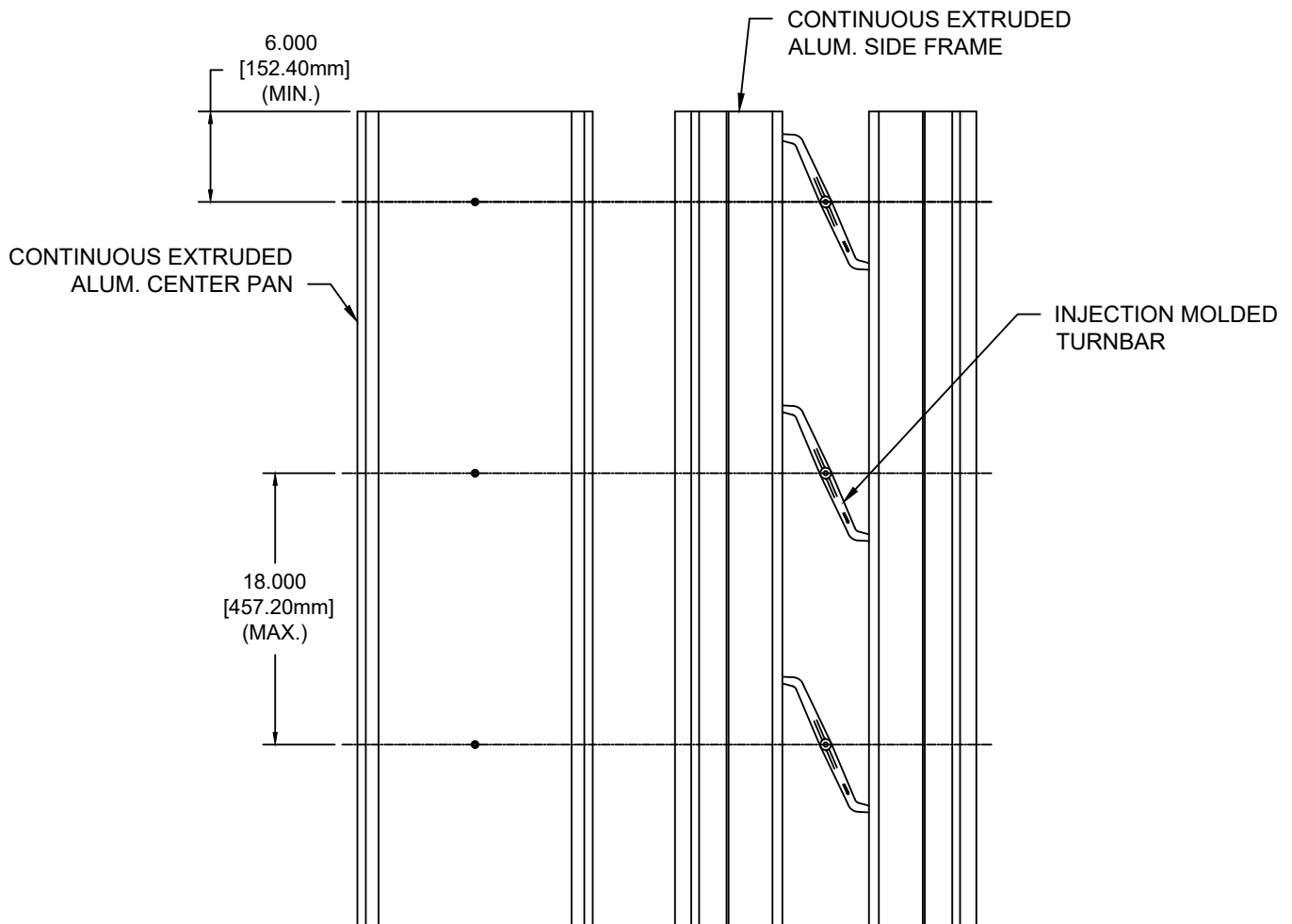

FIGURE 3.1

- 3.1) Begin installation of the Injection Molded Turnbars by determining the number of Turnbars needed for the length of the run. Turnbars are to be spaced starting at 6" [152.40mm] in from each end, with the second turnbar located at 18" [457.050mm] on center thereafter.
- 3.2) Determine the location of the Turnbars by laying a section of the Extruded Center Pan next to the previously installed Side Frames. Using a square or level and a pencil mark the location of the factory drilled holes (in the Extruded Center Pan) on the installed Side Frames. (See Figure 3.1)
- 3.3) Slide the Turnbars into the Turnbar receivers of the Side Frames and position the Turnbars to the pencil marks on the Side Frames. The Turnbars should all be oriented in the same direction, and also the side with the stamped part number should be facing up.

# STEP 4

## END SIDE FRAME INSTALLATION



- 4.1) Begin installation of the last section of Side Frame by cutting it to length as needed.
- 4.2) Determine the number of Turnbars required and slide them into the turnbar receiver of the Side Frames.
- 4.3) Place the assembly into the blockout. Using the Side Frames as a template, drill hole for the CS supplied anchors per the manufactures guidelines. Remove the Side Frame and clean the holes. Reposition the Side Frames and anchor them into the blockout with the CS supplied anchor bolts per the manufacture's guidelines.
- 4.4) Reposition the turnbars to match up with the Center Pan. Once again, the Turnbars should all be oriented in the same direction, and also the side with the stamped part number should be facing up.

# STEP 5

## EXTRUDED CENTER PAN INSTALLATION

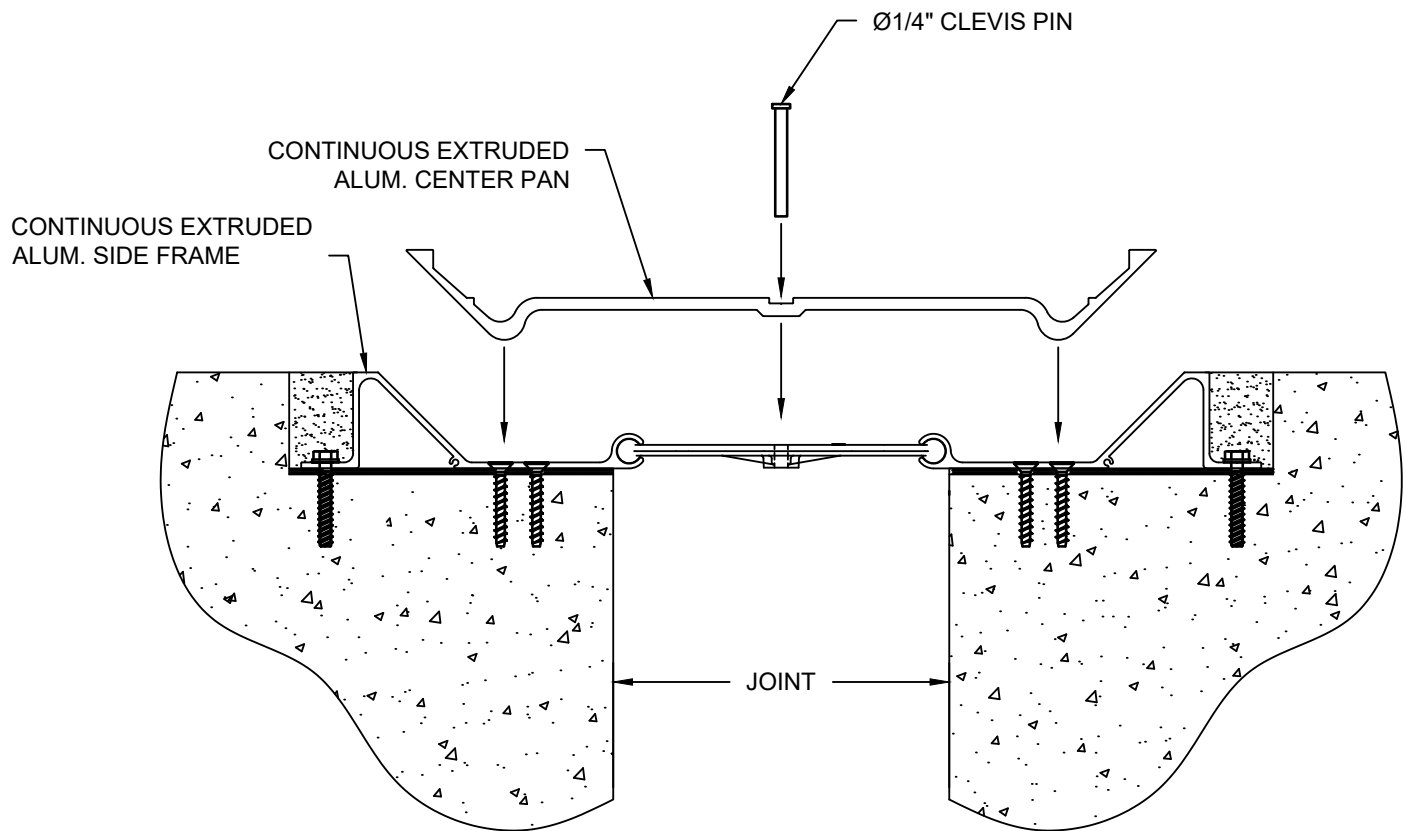

- 5.1) Place the Center Pan onto the previously installed Side Frames covering the Injection Molded Turnbars.
- 5.2) Line up the holes in the Center Pan with the holes in the center of each Turnbar. Minor Turnbar adjustments may be required and can be accomplished using a stiff wire or screw driver.
- 5.3) Once each Turnbar is located, insert a  $\text{Ø}1/4"$  Clevis Pin through the Center Pan and into the Turnbar. A small amount of silicone sealant (not supplied) can be used to seal off the hole for the Clevis Pin.
- 5.4) Repeat this procedure for each Turnbar until the entire run is complete.
- 5.5) Measure and cut the Center Pans to fit as needed.

# STEP 6

## PAN SPLICING

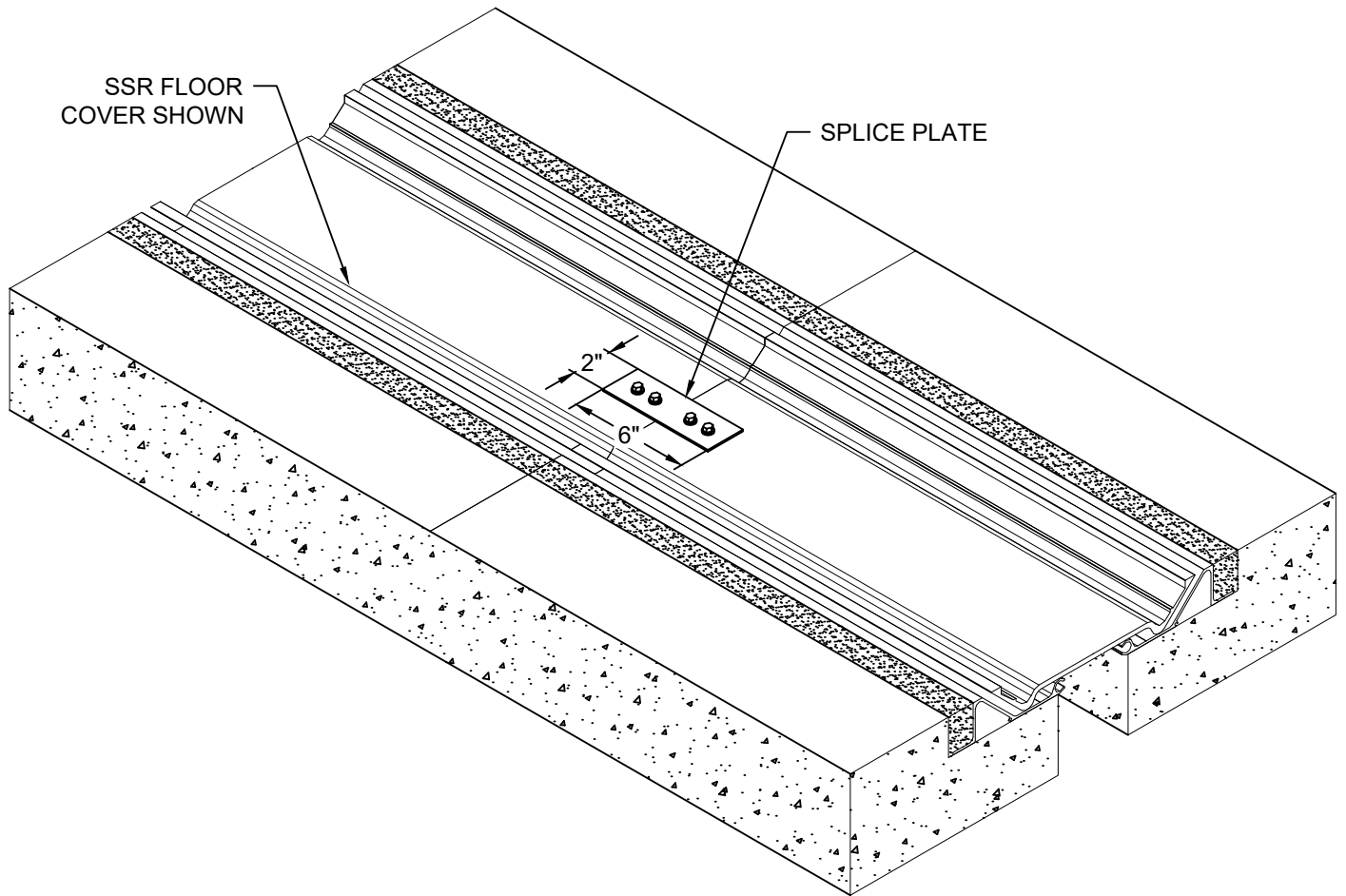

Note: Center pans are supplied in typical 10'-0" lengths. Each pan is to be field spliced to the adjacent pans to maintain alignment. A minimum 1/16" gap must be maintained between pans to allow for thermal expansion.

- 6.1) Place the next pan onto the frames as instructed in Step 5.
- 6.2) Slide the pan along the frames until the ends of the pans butt together. Separate slightly to maintain a minimum 1/16" gap.
- 6.3) Adjust the pans across the joint so that the top corners of the pan are in alignment.
- 6.4) Place a strip of masking tape or duct tape on top of the pans, over the butt joint, for the full width of the pan.
- 6.5) Center the CS supplied splice plate over the butt joint and attach to the pan using the supplied self-drilling tek screws.  
Note: Maintain the minimum 1/16" gap at the butt joint.

# STEP 7

## COMPLETE INSTALLATION

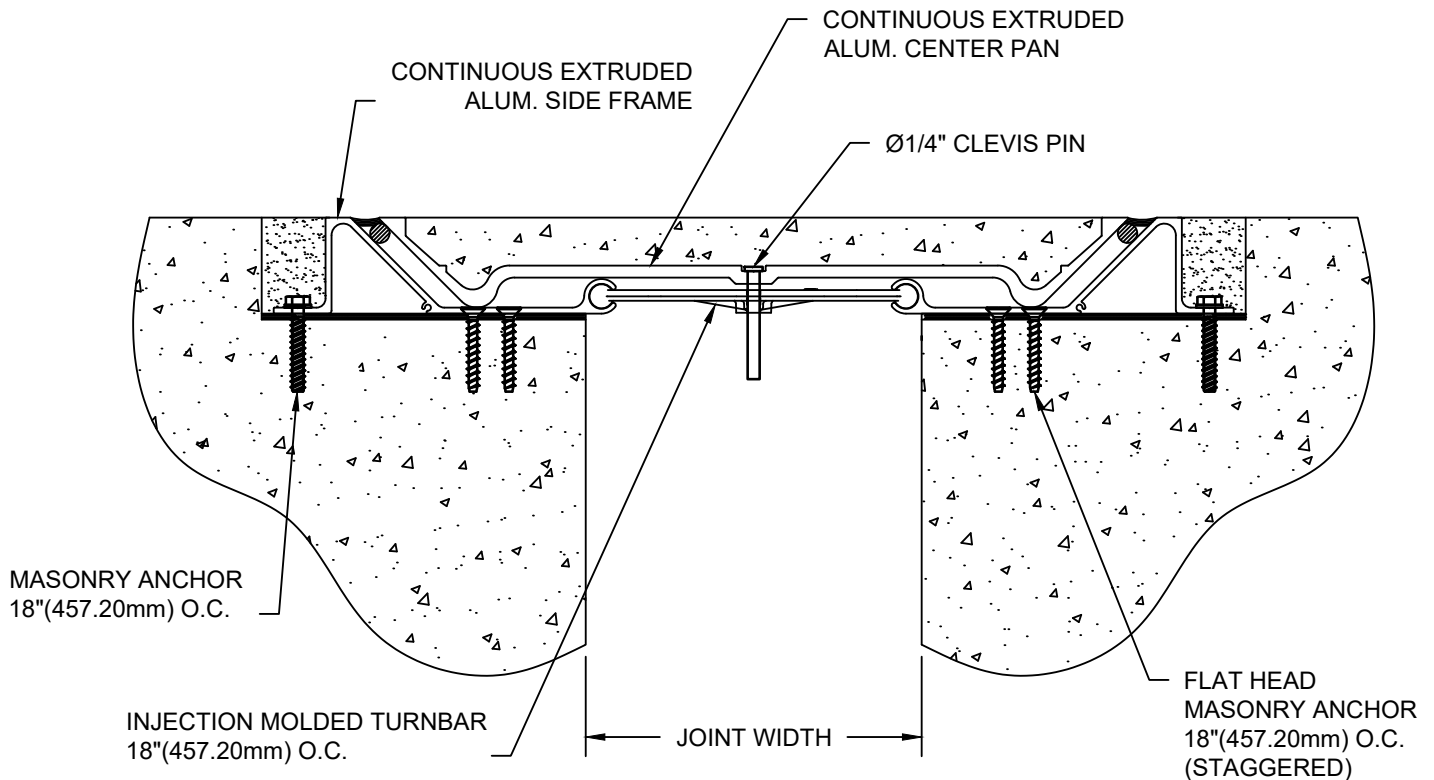

### Note:

With the joint cover assemblies installed for the full length of the run, the following steps will complete the installation. The steps do not necessarily have to be completed in the order shown.

- 6.1) Place the CS supplied oversized backer rod into the slot between the Side Frame and Center Pan, on each side of the joint, for the full length of the run. The backer rod should be positioned just below the exposed edges of the Frame and Center Pan. Note: The backer rod is used to prevent dirt and debris from gathering in the slot between the Frame and Center Pan that could hinder movement or the resting position of the Center Pan.
- 6.2) Place duct tape along the top surface of both the Side Frame and Center Pan so that it spans over the oversized backer rod. Note: The tape will protect the exposed surfaces while the grout and concrete fill are placed.
- 6.3) Fill the remaining blockout area, above the Side Frame anchors, with a quality high strength non-shrink grout (by others).
- 6.4) Prepare the Center Pan to receive the concrete fill. At the open ends of the center pan secure a pour stop angle (by others) to the pan. The angle should be flush with the top surface of the Center Pan.
- 6.5) In the Center Pan, place 4" x 4" - W2.9 X W2.9 rebar mesh (by others) along the full length of the run. The rebar mesh should span nearly the full width of the Center Pan, and should be positioned approximately half way between the top surface and the bottom of the Center Pan.

### IMPORTANT NOTE:

Select the proper concrete mix: Discuss with your local Concrete supplier Engineer to recommend a concrete for this special application in effort to prevent excessive shrinking, curling, and fracturing of the concrete from occurring. Recommendations include: Low water to cement ratio, #8 coarse aggregate, and/or a 60/40 cement to ash combination, greater full cure time (60 day minimum recommended), and a recommended shrinkage admixture. If concrete is being applied outside, a canopy or burlap should be used to minimize excessive differential curing from occurring. Concrete should not be installed if there is the possibilities the temperatures could drop below recommended curing temperatures during the curing cycle.

- 6.6) Fill the Center Pan with the selected concrete (concrete by others) Float the concrete level with the exposed edges of the Pan. Smooth and finish as required. Apply misters for moist curing (see Important Note:)



# STEP 7 CONT.

## COMPLETE INSTALLATION

### IMPORTANT NOTE:

Measures must be taken to prevent excess shrinking and curling from occurring. Construction Specialties recommends the installer moist cure the concrete for a minimum of 12 days. During the final 5 days reduce duration of moist curing incrementally. These efforts will aid in the reduction of differential curing from occurring causing warping of the concrete and possibly damaging the aluminum pans.

Included below are links to articles and documentation for additional resources to aid in the reduction of shrinking and warping caused by improperly specified or curing of the concrete.

[http://www.cement.org/tech/cct\\_floors\\_shrinkage.asp](http://www.cement.org/tech/cct_floors_shrinkage.asp)

[http://www.nrc-cnrc.gc.ca/ctu-sc/ctu\\_sc\\_n44](http://www.nrc-cnrc.gc.ca/ctu-sc/ctu_sc_n44)

### IMPORTANT NOTE:

After all misting and troweling has been completed, apply the recommended water based concrete curing compound (not a cure and seal) (by others) to the entire surface of the concrete.

- 6.7) When the concrete has set or after any other floor finish work is complete, remove the duct tape from along the exposed surface of the Pan and Base Frames. Before removing the oversized backer rod, vacuum off the top surface to remove all loose grout, concrete, dirt and debris that might fall into the slot as the backer rods are removed. Then remove the backer rods.
- 6.8) Place new backer rods (by others) and caulking (by others) along the full length of the slots between the Pan and Base Frames. The caulk should be smooth and level with the exposed surfaces of the Frame and Pan. Note: To provide the proper thermal expansion and compression capability, select a caulking that will provide  $\pm 50\%$  movement capability per nominal width. We recommend using Sika® 2C NS where available. The caulking should be applied per the manufactures recommendations and width to depth ratio.

THE INSTALLATION SHOULD NOW BE COMPLETE. PROTECT THE INSTALLATION UNTIL FINAL ARCHITECTURAL INSPECTION.