

COLOR: _____
 HANDRAIL WOOD SPECIES: _____
 HANDRAIL WOOD FINISH: _____
 CRASH RAIL: _____
 *MOUNTING BRACKET: _____
 COLOR TO BE SELECTED FROM ONE OF C/S STANDARD COLORS.

*MOUNTING BRACKET SUPPLIED IN STANDARD MILL FINISH. OPTIONAL CLEAR ANODIZED AND POWDER COAT FINISH AVAILABLE. PLEASE ADVISE POWDER COAT FINISH IF REQUIRED.

TOTAL L/F REQ'D	LEFT END CAPS	RIGHT END CAPS	O.S.C. REQ'D

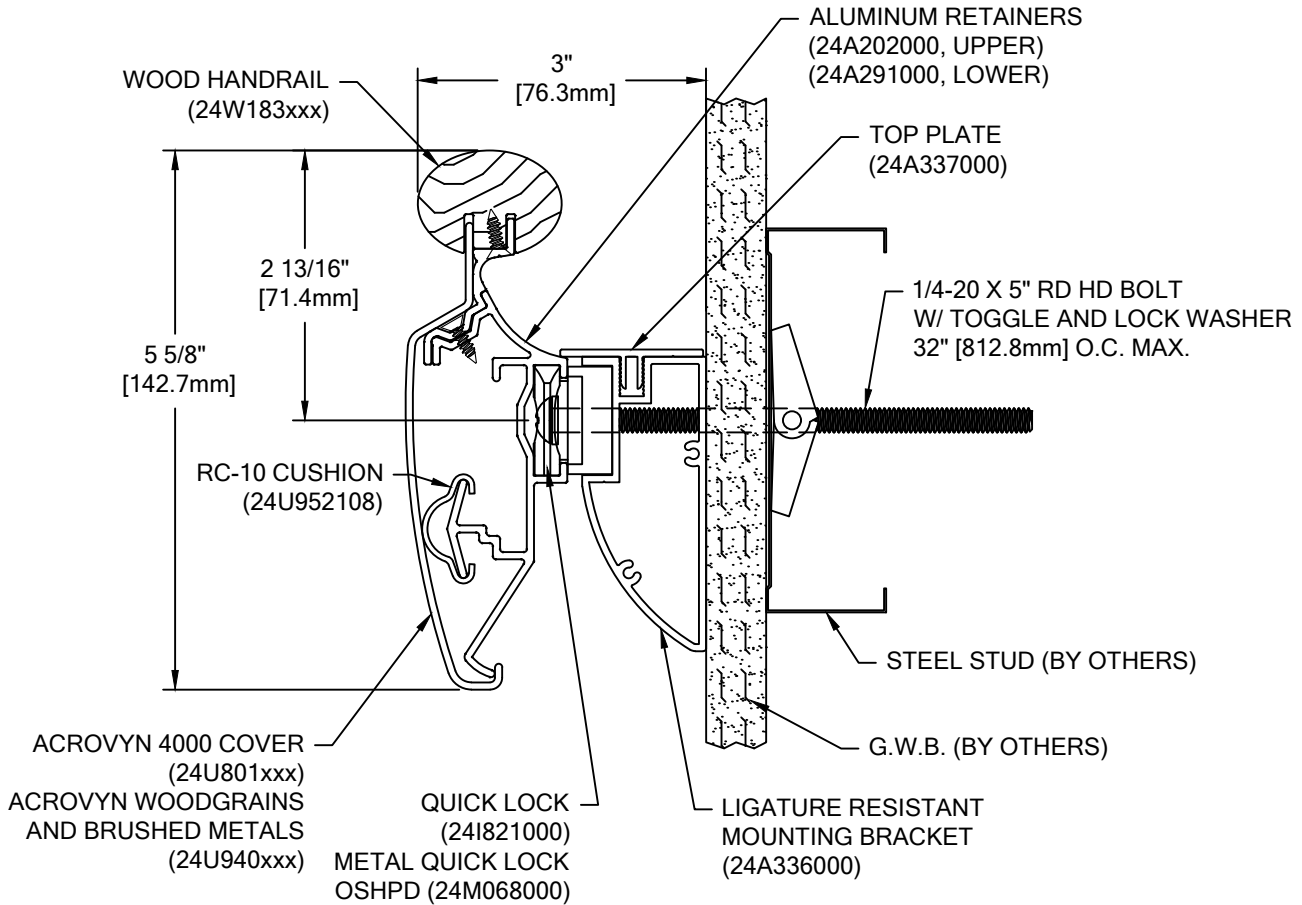

HRBW-20CMN

ACROVYN 4000

WALL CONDITION	SPECIFIED FASTENER	DRILL DIAMETERS		C/S PART NUMBER
		WALL	RETAINER	
STEEL STUD/GYPSUM WALL	1/4-20 X 5" ROUND HEAD BOLT WITH TOGGLE, AND LOCK WASHER	3/4"	N/A	90H049002 90H006003
CONCRETE/CONCRETE BLOCK	#14 X 5" PHILLIPS RD HD ALL-PURPOSE SCREW	3/16"	N/A	90H287002
WOOD STUD/GYPSUM WALL	#14 X 5" PHILLIPS RD HD ALL-PURPOSE SCREW	1/8"	N/A	90H287002
20 GA. STEEL STUD/GYPSUM WALL (OSHPD)	1/4-20 X 5" RD. HD. BOLT WITH FLAT WASHER 1/4" TOGGLER WING 3M MOLDABLE FIRE PUTTY	1/2"	N/A	90H659002 90H007003 90H062004 90M012000

 <p>Construction Specialties™ 6696 Route 405 Highway, Muncy PA 17756 (800) 233-8493 • Fax (570) 546-4692 • www.c-sgroup.com</p>	PROJECT:	REVISION:
	JOB NO.:	F&F:
	CUSTOMER:	
	REP:	DATE:
	DRAWN BY:	SHEET NO: