

## FIRE RATED DOOR AND EDGE PROTECTION

### PLEASE READ

PLEASE READ THESE INSTRUCTIONS THOROUGHLY PRIOR TO BEGINNING THE FIRE RATED DOOR AND EDGE PROTECTION INSTALLATION!

THIS INSTRUCTION SHEET IS INTENDED TO PROVIDE A SPECIFIC GUIDE TO FOLLOW FOR THE INSTALLATION OF FIRE RATED DOOR AND EDGE PROTECTION. CONTAINED WITHIN IS THE TECHNICAL INFORMATION AND INSTALLATION TECHNIQUES REQUIRED TO COMPLETE AN EFFICIENT, NEAT AND LONG-LASTING INSTALLATION.

INSPECT ALL MATERIALS FOR DAMAGE OR MISSING PARTS. IF YOU DISCOVER DAMAGED OR MISSING MATERIALS, IN THE USA PLEASE NOTIFY THE FACTORY AT (800) 233-8493, AND IN CANADA (888) 895-8955.

FIRE RATED DOOR AND EDGE PROTECTION MUST BE INSTALLED IN ACCORDANCE WITH THESE INSTRUCTIONS! FAILURE TO FOLLOW THESE INSTRUCTIONS MAY VOID ANY PRODUCT WARRANTIES AND RESULT IN AN UNSUCCESSFUL INSTALLATION. FOR SPECIFIC QUESTIONS REGARDING THE INSTALLATION OF FIRE RATED DOOR AND EDGE PROTECTION PLEASE CALL THE FACTORY AT (800) 233-8493 OR EMAIL IWPTECHSUPPORT@C-SGROUP.COM. IN CANADA CALL (888) 895-8955.

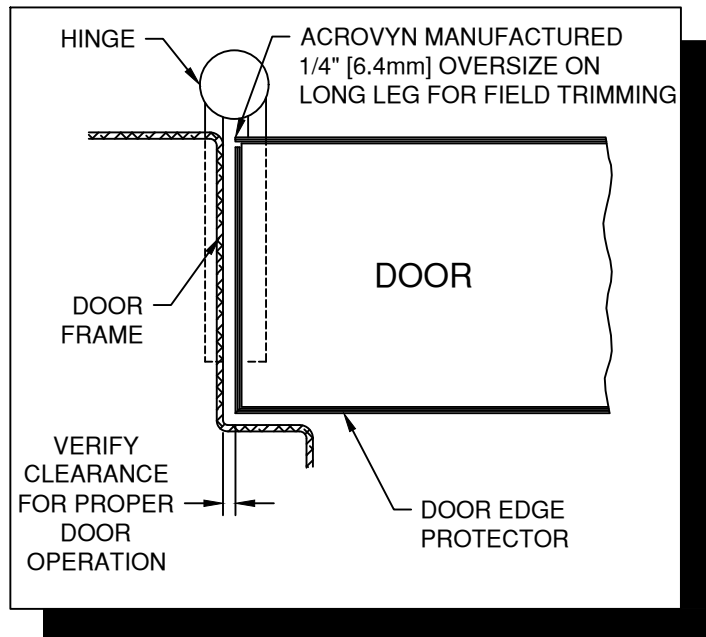

**DOOR (DP) AND EDGE (EP) PROTECTORS**

### IMPORTANT NOTES

1. ALL DIMENSIONS ARE TYPICAL.
2. MATERIAL MUST REACH 65°F MIN. TO 75°F MAX. 24 HOURS PRIOR TO INSTALLATION. THIS IS ESSENTIAL TO MINIMIZE EXPANSION AND CONTRACTION OF MATERIAL.
3. DO NOT EXPOSE TO ELEVATED TEMPERATURES OR DIRECT SUNLIGHT AFTER INSTALLATION. THIS WILL CAUSE THE SURFACE TEMPERATURE TO RISE, WHICH IN TURN WILL CAUSE BUBBLES AND DELAMINATION.
4. ONE 3DP UNIT EQUALS ONE "L" SHAPED PIECE, UNLESS OTHERWISE NOTED.
5. ONE WH (WARNOCK HERSEY) LABEL AND COMPANY IDENTIFIER PER ACROVYN ASSEMBLY.
6. FOR MORE INFORMATION ON FIRE RATED DOOR AND EDGE PROTECTORS SEE OUR WEBSITE AT [www.c-sgroup.com](http://www.c-sgroup.com).

# FIRE RATED DOOR AND EDGE PROTECTION

ACROVYN 3DPN SERIES (DOOR CLADDING)

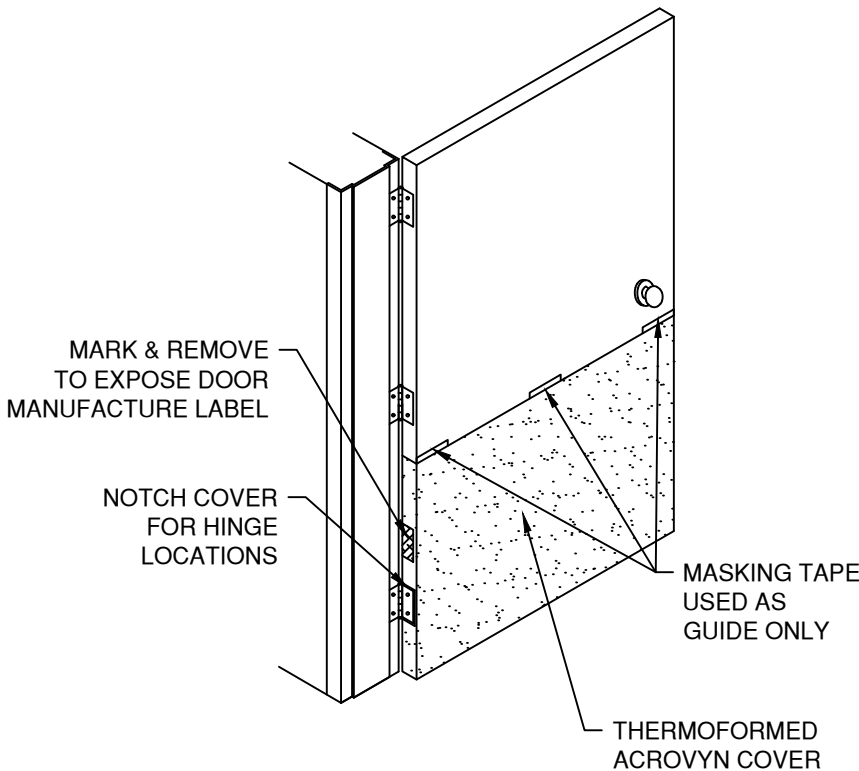
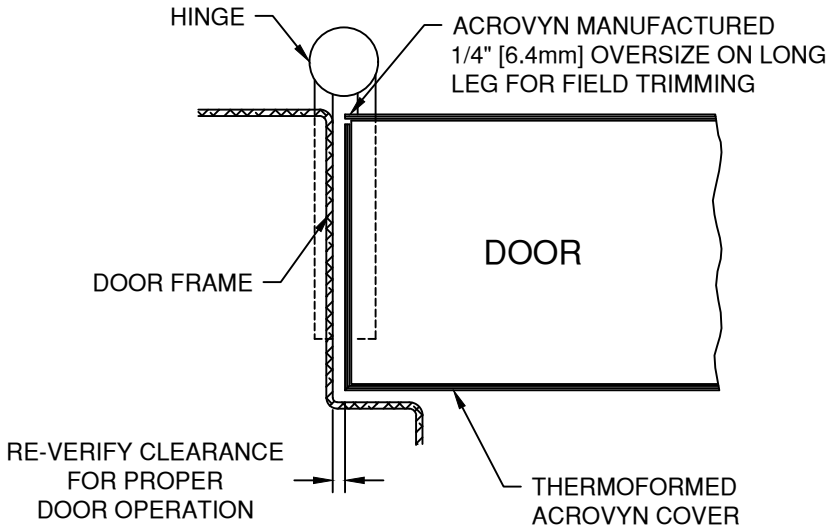

1. ACCLIMATE ALL MATERIALS TO ROOM TEMPERATURE 24 HOURS PRIOR TO INSTALLATION. THE MATERIALS SHOULD NOT BE INSTALLED AT AMBIENT ROOM TEMPERATURES BELOW 65° F.
2. THE INSTALLATION SURFACE MUST BE THOROUGHLY CLEANED, FREE OF DIRT, GREASE, WAX, OIL, AND LOOSE PAINT.
3. ESTABLISH LOCATION BY DRY FITTING MATERIALS TO THE DOOR. CHECK DOOR TO FRAME CLEARANCE FOR ANY POTENTIAL INTERFERENCE. IT MAY BE NECESSARY TO SAND OR PLANE THE DOOR TO MAINTAIN PROPER DOOR OPERATION.
4. MARK THE LOCATION OF THE DOOR MANUFACTURER'S LABEL UPON THE ACROVYN COVER AND CUT THE ACROVYN TO EXPOSE THE LABEL.

TAPE APPLICATIONS

5. MASKING TAPE MAY BE UTILIZED AS A POSITIONING GUIDE DURING INSTALLATION.
6. PEEL THE PAPER BACKING FROM THE BACK AND POSITION IT PROPERLY.
7. APPLY PRESSURE TO THE ENTIRE SURFACE. PRESSURE ROLL THE MATERIALS TO SET THE ADHESIVE.
8. REMOVE MASKING TAPE, IF USED.

ADHESIVE APPLICATIONS

5. MASK AREA DIRECTLY ADJACENT THE DOOR PROTECTION TO AVOID OVER SPREADING OF THE CONTACT ADHESIVE. MASKING TAPE MAY ALSO BE UTILIZED AS A POSITIONING GUIDE DURING INSTALLATION OF THE MATERIAL.
6. APPLY THE CONTACT ADHESIVE TO THE DOOR AND MATERIAL IN ACCORDANCE WITH THE ADHESIVE INSTRUCTIONS.
7. ONCE THE CONTACT ADHESIVE HAS DRIED, POSITION THE MATERIAL ON THE DOOR. PRESSURE ROLL THE MATERIAL TO SET THE ADHESIVE.
8. DOOR ENVELOPE PROTECTORS MUST BE TRIMMED AND BEVELED FOLLOWING INSTALLATION. THIS IS BEST DONE THROUGH USE OF A ROUTER WITH A "LAMINATE TAPERED TRIM BIT."
9. REMOVE MASKING TAPE, IF USED.

CAUTION: DO NOT EXPOSE DOOR PROTECTION TO ELEVATED TEMPERATURES OR DIRECT SUNLIGHT AFTER THE INSTALLATION. THIS WILL CAUSE THE SURFACE TEMPERATURE TO RISE, WHICH IN TURN WILL CAUSE BUBBLES AND DELAMINATION.

NOTE: ONE 3DP UNIT EQUALS ONE "L" SHAPED PIECE.

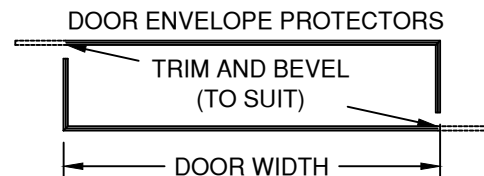

CONDITION	SPECIFIED FASTENER	QUANTITY	CS PART NUMBER
WOOD DOORS	DOUBLE SIDED TAPE	FACTORY APPLIED	90M183002
WOOD DOORS	FASTBOND 30 ADHESIVE	5 GALLON 1 GALLON 1 QUART	90M016001 90M014001 90M015001

**FIRE RATED DOOR AND EDGE PROTECTION**

ACROVYN 4000 EP SERIES

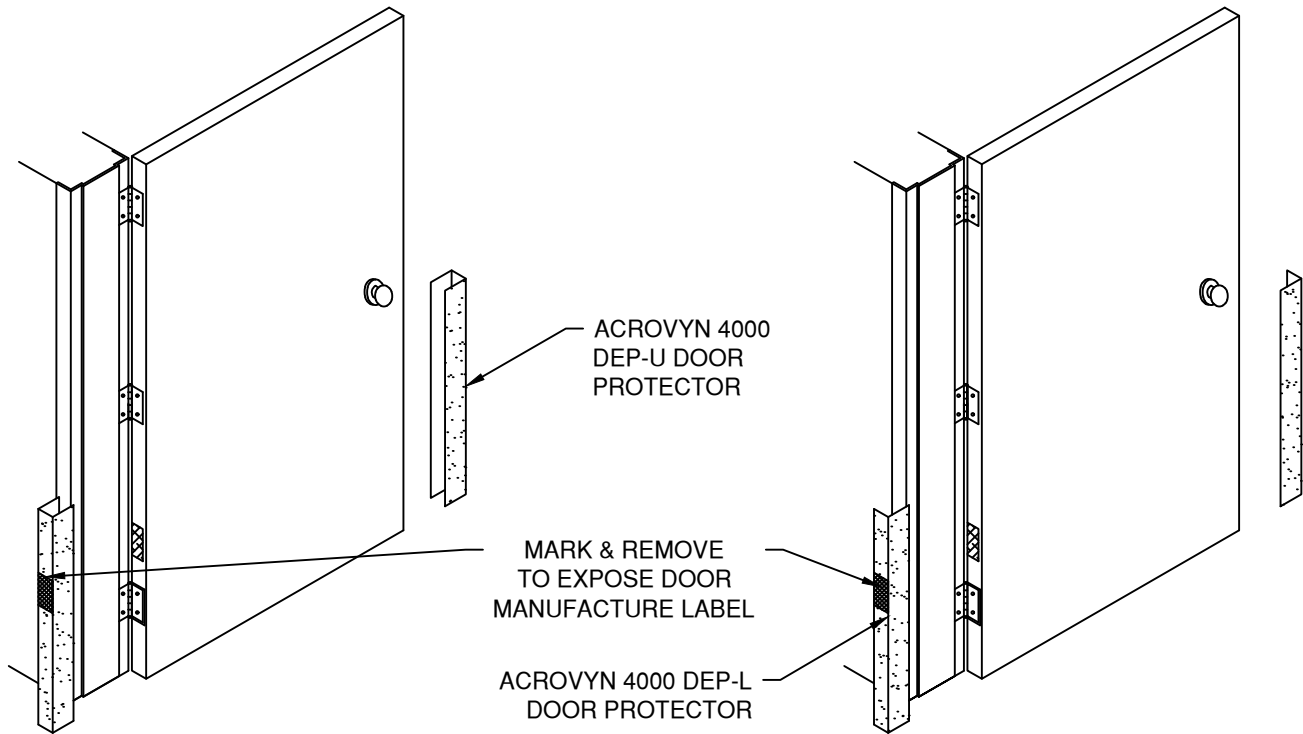

1. ACCLIMATE ALL MATERIALS TO ROOM TEMPERATURE 24 HOURS PRIOR TO INSTALLATION. THE MATERIALS SHOULD NOT BE INSTALLED AT AMBIENT ROOM TEMPERATURES BELOW 65° F.
2. THE INSTALLATION SURFACE MUST BE THOROUGHLY CLEANED, FREE OF DIRT, GREASE, WAX, OIL, AND LOOSE PAINT.
3. ESTABLISH DOOR PROTECTION LOCATION BY DRY FITTING MATERIALS TO THE DOOR. CHECK DOOR TO FRAME CLEARANCE FOR ANY POTENTIAL INTERFERENCE. IT MAY BE NECESSARY TO SAND OR PLANE THE DOOR TO MAINTAIN PROPER DOOR OPERATION.
4. MARK THE LOCATION OF THE DOOR MANUFACTURER'S LABEL UPON THE ACORVYN COVER AND CUT OUT THE ACROVYN TO EXPOSE THE LABEL.

TAPE APPLICATIONS

5. MASKING TAPE MAY BE UTILIZED AS A POSITIONING GUIDE DURING INSTALLATION.
6. PEEL THE PAPER BACKING FROM THE BACK AND POSITION IT PROPERLY.
7. APPLY PRESSURE TO THE ENTIRE SURFACE. PRESSURE ROLL THE MATERIALS TO SET THE ADHESIVE.
8. REMOVE MASKING TAPE, IF USED.

ADHESIVE APPLICATIONS

5. MASK AREA DIRECTLY ADJACENT THE DOOR PROTECTION TO AVOID OVER SPREADING OF THE CONTACT ADHESIVE. MASKING TAPE MAY ALSO BE UTILIZED AS A POSITIONING GUIDE DURING INSTALLATION OF THE MATERIAL.
6. APPLY THE CONTACT ADHESIVE TO THE DOOR AND MATERIAL IN ACCORDANCE WITH THE ADHESIVE INSTRUCTIONS.
7. ONCE THE CONTACT ADHESIVE HAS DRIED, POSITION THE DOOR PROTECTION ON THE DOOR. PRESSURE ROLL THE MATERIALS TO SET THE ADHESIVE.
8. DOOR ENVELOPE PROTECTORS MUST BE TRIMMED AND BEVELED FOLLOWING INSTALLATION. THIS IS BEST DONE THROUGH USE OF A ROUTER WITH A "LAMINATE TAPERED TRIM BIT."
9. REMOVE MASKING TAPE, IF USED.

CAUTION: DO NOT EXPOSE DOOR PROTECTION TO ELEVATED TEMPERATURES OR DIRECT SUNLIGHT AFTER THE INSTALLATION. THIS WILL CAUSE THE SURFACE TEMPERATURE TO RISE, WHICH IN TURN WILL CAUSE BUBBLES AND DELAMINATION.

CONDITION	SPECIFIED FASTENER	QUANTITY	CS PART NUMBER
WOOD DOORS	DOUBLE SIDED TAPE	FACTORY APPLIED	90M183002
WOOD DOORS	FASTBOND 30 ADHESIVE	5 GALLON 1 GALLON 1 QUART	90M016001 90M014001 90M015001

**FIRE RATED DOOR AND EDGE PROTECTION**  
 STAINLESS STEEL EP SERIES

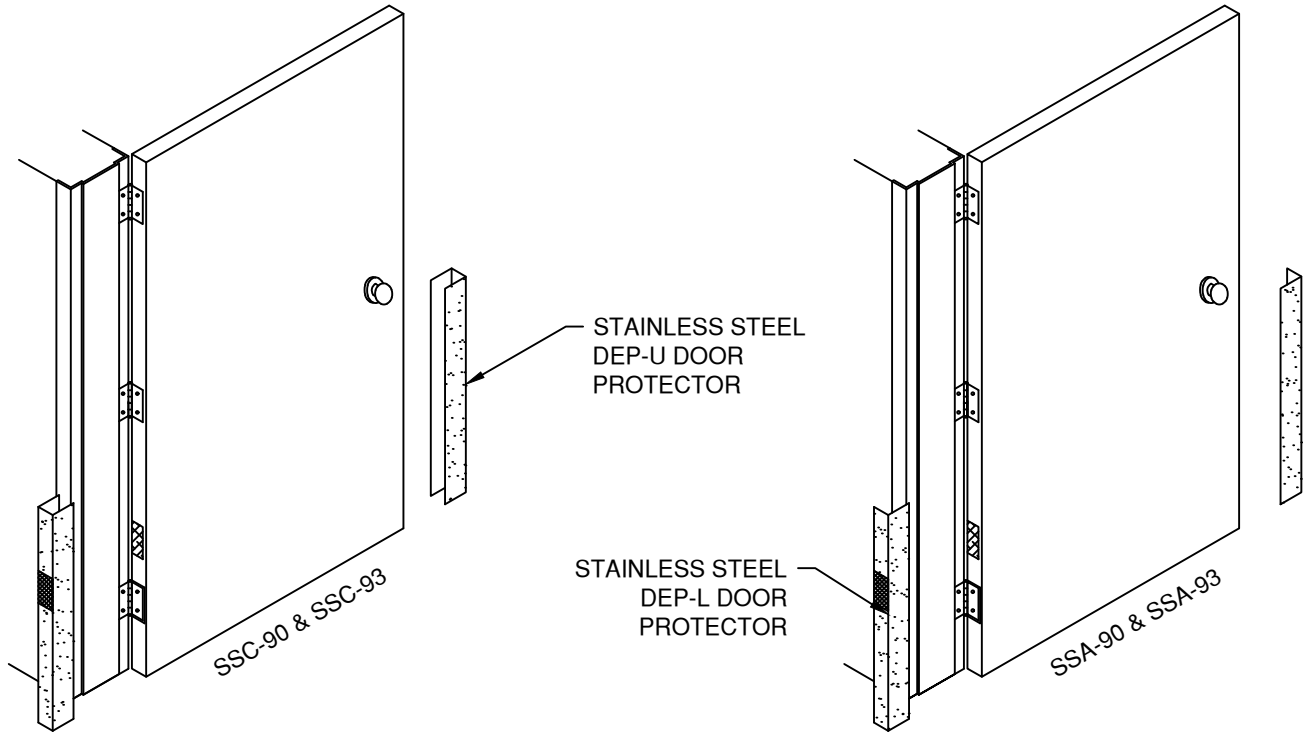

1. ACCLIMATE ALL MATERIALS TO ROOM TEMPERATURE 24 HOURS PRIOR TO INSTALLATION. THE MATERIALS SHOULD NOT BE INSTALLED AT AMBIENT ROOM TEMPERATURES BELOW 65° F.
2. THE INSTALLATION SURFACE MUST BE THOROUGHLY CLEANED, FREE OF DIRT, GREASE, WAX, OIL, AND LOOSE PAINT.
3. ESTABLISH DOOR PROTECTION LOCATION BY DRY FITTING MATERIALS TO THE DOOR. CHECK DOOR TO FRAME CLEARANCE FOR ANY POTENTIAL INTERFERENCE. IT MAY BE NECESSARY TO SAND OR PLANE THE DOOR TO MAINTAIN PROPER DOOR OPERATION.
4. MASK AREA DIRECTLY ADJACENT THE DOOR PROTECTION TO AVOID OVER SPREADING OF THE CONTACT ADHESIVE. MASKING TAPE MAY ALSO BE UTILIZED AS A POSITIONING GUIDE DURING INSTALLATION.
5. APPLY THE CONTACT ADHESIVE TO THE DOOR AND MATERIALS IN ACCORDANCE WITH THE ADHESIVE INSTRUCTIONS.
6. ONCE THE CONTACT ADHESIVE HAS DRIED, POSITION THE DOOR PROTECTION ON THE DOOR. PRESSURE ROLL THE MATERIALS TO SET THE ADHESIVE.
7. REMOVE MASKING TAPE, IF USED.

CAUTION: DO NOT EXPOSE DOOR PROTECTION TO ELEVATED TEMPERATURES OR DIRECT SUNLIGHT AFTER THE INSTALLATION. THIS WILL CAUSE THE SURFACE TEMPERATURE TO RISE, WHICH IN TURN WILL CAUSE BUBBLES AND DELAMINATION.

CONDITION	SPECIFIED FASTENER	QUANTITY	CS PART NUMBER
WOOD DOORS	FASTBOND 30 ADHESIVE	5 GALLON 1 GALLON 1 QUART	90M016001 90M014001 90M015001

11/04/19