

COLOR:
 TOP RAIL WOOD SPECIES: _____
 TOP RAIL WOOD FINISH: _____
 *END CAPS: _____
 COLOR TO BE SELECTED FROM ONE OF CS STANDARD COLORS.
 *CAPS/CORNERS ARE AVAILABLE WITH AN OPTIONAL POWDER COAT FINISH.
 PLEASE ADVISE POWDER COAT FINISH IF REQUIRED.
 WOOD END CAPS AND INSIDE/OUTSIDE CORNERS ALSO AVAILABLE.

NOTE: STAINLESS STEEL CORNERS OTHER THAN 90° ARE UNAVAILABLE FOR THIS MODEL. THIS MODEL IS FABRICATED CUT-TO-SIZE, THEREFORE FIELD VERIFIED DIMENSIONS ARE REQUIRED.

| TOTAL L/F REQ'D | END CAPS | I.S.C. REQ'D | O.S.C. REQ'D |
|-----------------|----------|--------------|--------------|
| | | | |
| | | | |
| | | | |

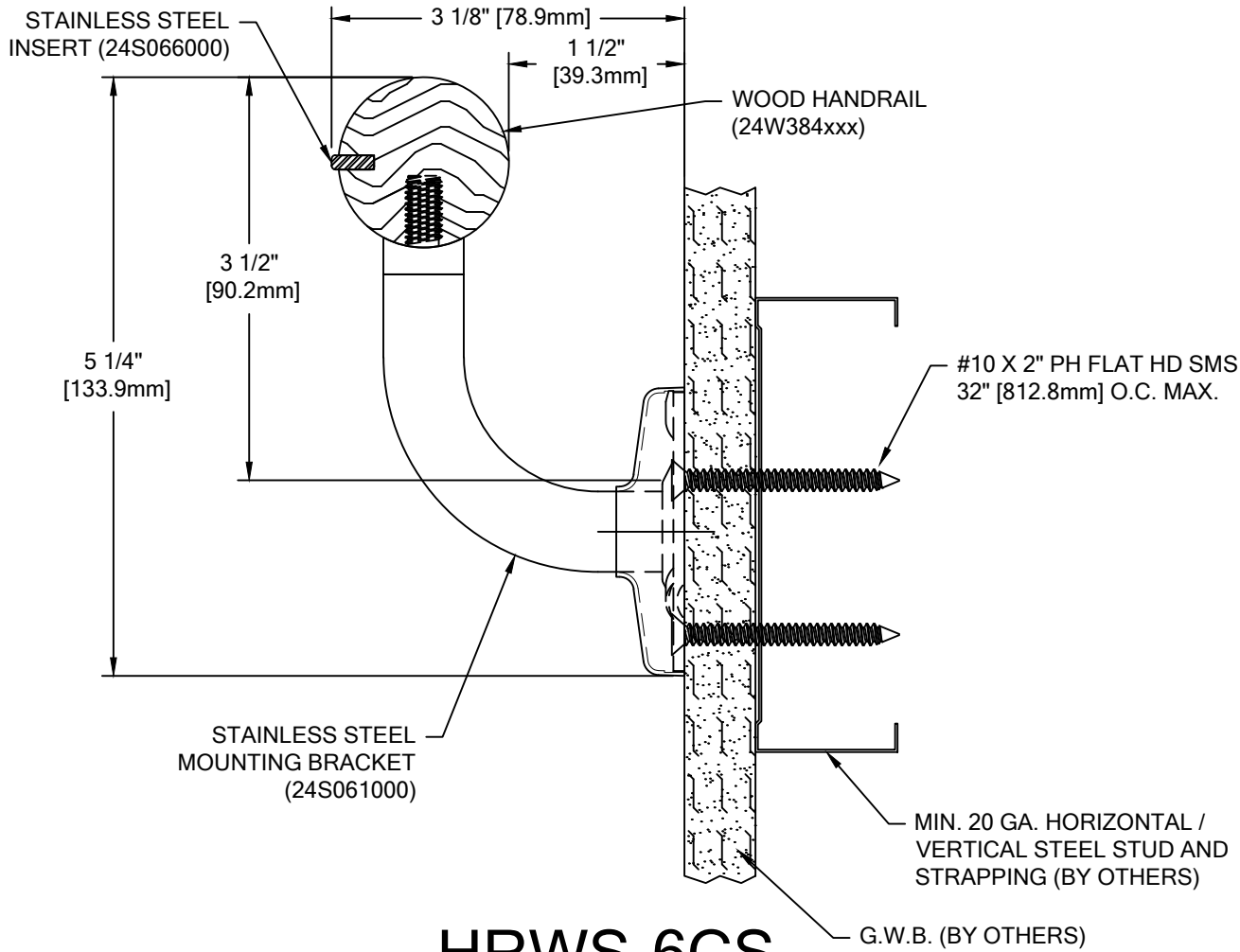

HRWS-6CS

| WALL CONDITION | SPECIFIED FASTENER | DRILL DIAMETERS | | CS PART NUMBER |
|---------------------------------------|--|-----------------|----------|-------------------------------------|
| | | WALL | RETAINER | |
| STEEL STUD/GYPUSM WALL | #10 X 2" PHILLIPS FLAT HEAD SHEET METAL SCREW | 1/16" | N/A | 90H431002 |
| CONCRETE/CONC. BLOCK | 1/4" X 2 1/4" HEX HEAD MASONRY | 3/16" | N/A | 90H027004 |
| WOOD STUD/GYPUSM WALL | #9 X 2 1/4" PHILLIPS WAFER HEAD DRYWALL SCREW | N/A | N/A | 90H421002 |
| 20 GA. STEEL STUD/GYPUSM WALL (OSHPD) | 1/4"-20 X 3" FLAT HEAD BOLT 1/4" TOGGLER WING 3M MOLDABLE FIRE PUTTY | 1/2" | N/A | 90H282002 90H062004 90M012000 |

| | | |
|---|------------------|------------------|
|  <p>Hughesville, PA 800.233.8493 570.546.5941 Mississauga, ON 888.895.8955 905.274.3611 www.c-sgroup.com</p> <p>© Copyright 2019 Construction Specialties, Inc.</p> | PROJECT: | REVISION: |
| | JOB NO.: | F&F: |
| | CUSTOMER: | |
| | REP: | DATE: |
| | DRAWN BY: | SHEET NO: |