

Model A6097
6" (152.4 mm) High Performance Drainable Fixed Mullion Louver

Material:

Material:	6063-T6 Alloy
Nominal Thickness (heads, sills, jamps, & mullions):	0.081" (2.06 mm)
Nominal Blade Thickness:	0.081" (2.06 mm)
Furnished With:	Birdscreen: ½" intercrimp aluminum mesh, 0.063" diameter wire removeable aluminum bird screen in an aluminum frame
Additional Options (at additional cost):	Insect screen (in lieu of bird screen), Continuous clip angles for attachment Sheet blank off, Insulated blank off Sill pans, Flange frames Integrated glazing frames



Test Summary:
For a 4 Foot by 4 Foot Unit.

Tested with mill finish and no screen

- Free area = 8.34 ft² (0.775 m²)
- Percent free area = 52.1%
- Free area velocity at the point of beginning water penetration (@ 0.01oz. / ft² of free area based on a 15 minute interval test) = 1190 FPM (6.05 m/s)
- Intake pressure drop at 0.01 oz. / ft² free area velocity = 0.23 in. H₂O (57.1 Pa)

Construction Specialties Inc. certifies that the louver model A6097 shown herein is licensed to bear the AMCA Seal. The ratings shown are based on tests and procedures performed in accordance with AMCA Publication 511 and comply with the requirements of the AMCA Certified ratings Program. The AMCA Certified Ratings Seal applies to air performance ratings and water penetration ratings.

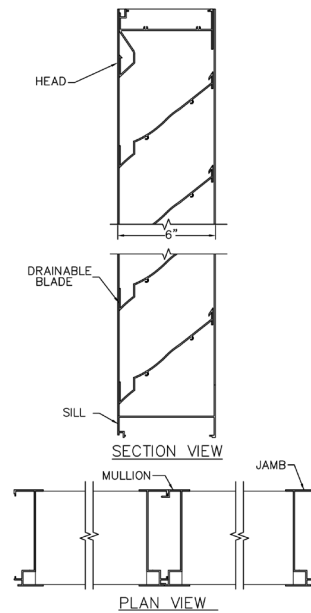

Discharge Coefficient
 Intake Cd = 0.39 (Class 2)
 AMCA certifies the coefficient class only



Model A6097

6" (152.4 mm) High Performance Drainable Fixed Mullion Louver

Water Penetration Statement

AMCA defines the point of beginning water penetration as the free area velocity at which the AMCA water test has yielded 0.01 or less ounces of water per square foot of louver free area during a 15-minute test period.

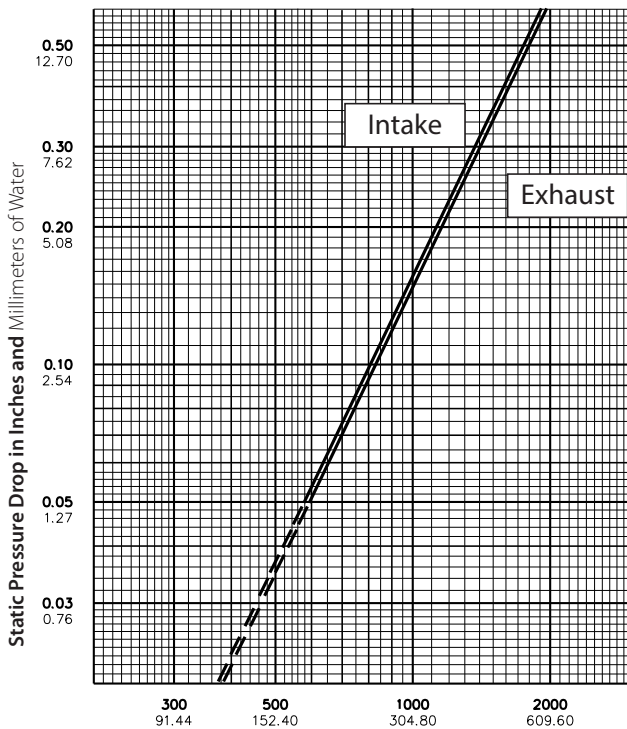

Air Velocity in Feet and Meters per Minute Through Free Area

Data corrected to standard air density.
48" x 48" louver tested to figure 5.5.

Free Area Table (Free area in sq. feet and sq. meters)

For additional sizes, please visit:

<https://www.c-sgroup.com/architectural-louvers/louvers-airflow-tool>

	Width in Inches and Meters									
	12	18	24	30	36	42	48	54	60	
	0.30	0.46	0.61	0.76	0.91	1.07	1.22	1.37	1.52	
24	0.62	1.06	1.49	1.93	2.37	2.81	3.24	3.68	4.12	
	0.61	0.06	0.10	0.14	0.18	0.22	0.26	0.30	0.34	0.38
30	0.86	1.47	2.08	2.69	3.30	3.91	4.52	5.13	5.74	
	0.76	0.08	0.14	0.19	0.25	0.31	0.36	0.42	0.48	0.53
36	1.11	1.89	2.67	3.45	4.23	5.01	5.79	6.57	7.35	
	0.91	0.10	0.18	0.25	0.32	0.39	0.47	0.54	0.61	0.68
42	1.35	2.30	3.25	4.21	5.16	6.11	7.07	8.02	8.97	
	1.07	0.13	0.21	0.30	0.39	0.48	0.57	0.66	0.74	0.83
48	1.59	2.72	3.84	4.97	6.09	7.22	8.34	9.46	10.59	
	1.22	0.15	0.25	0.36	0.46	0.57	0.67	0.77	0.88	0.98
54	1.84	3.13	4.43	5.72	7.02	8.32	9.61	10.91	12.21	
	1.37	0.17	0.29	0.41	0.53	0.65	0.77	0.89	1.01	1.13
60	2.08	3.55	5.02	6.48	7.95	9.42	10.89	12.35	13.82	
	1.52	0.19	0.33	0.47	0.60	0.74	0.88	1.01	1.15	1.28
66	2.32	3.96	5.60	7.24	8.88	10.52	12.16	13.80	15.44	
	1.68	0.22	0.37	0.52	0.67	0.83	0.98	1.13	1.28	1.43
72	2.57	4.38	6.19	8.00	9.81	11.62	13.43	15.25	17.06	
	1.83	0.24	0.41	0.57	0.74	0.91	1.08	1.25	1.42	1.58
78	2.81	4.79	6.78	8.76	10.74	12.73	14.71	16.69	18.67	
	1.98	0.26	0.45	0.63	0.81	1.00	1.18	1.37	1.55	1.73
84	3.05	5.21	7.36	9.52	11.67	13.83	15.98	18.14	20.29	
	2.13	0.28	0.48	0.68	0.88	1.08	1.28	1.48	1.69	1.89
90	3.30	5.62	7.95	10.28	12.60	14.93	17.26	19.58	21.91	
	2.29	0.31	0.52	0.74	0.95	1.17	1.39	1.60	1.82	2.04
96	3.54	6.04	8.54	11.03	13.53	16.03	18.53	21.03	23.53	
	2.44	0.33	0.56	0.79	1.03	1.26	1.49	1.72	1.95	2.19
102	3.78	6.45	9.12	11.79	14.46	17.13	19.80	22.47	25.14	
	2.59	0.35	0.60	0.85	1.10	1.34	1.59	1.84	2.09	2.34
108	4.03	6.87	9.71	12.55	15.39	18.24	21.08	23.92	26.76	
	2.74	0.37	0.64	0.90	1.17	1.43	1.69	1.96	2.22	2.49
114	4.27	7.28	10.30	13.31	16.32	19.34	22.35	25.37	28.38	
	2.90	0.40	0.68	0.96	1.24	1.52	1.80	2.08	2.36	2.64
120	4.51	7.70	10.88	14.07	17.25	20.44	23.63	26.81	30.00	
	3.05	0.42	0.72	1.01	1.31	1.60	1.90	2.19	2.49	2.79
126	4.76	8.11	11.47	14.83	18.18	21.54	24.90	28.26	31.61	
	3.20	0.44	0.75	1.07	1.38	1.69	2.00	2.31	2.63	2.94
132	5.00	8.53	12.06	15.59	19.11	22.64	26.17	29.70	33.23	
	3.35	0.46	0.79	1.12	1.45	1.78	2.10	2.43	2.76	3.09
138	5.24	8.94	12.64	16.34	20.05	23.75	27.45	31.15	34.85	
	3.51	0.49	0.83	1.17	1.52	1.86	2.21	2.55	2.89	3.24
144	5.49	9.36	13.23	17.10	20.98	24.85	28.72	32.59	36.47	
	3.66	0.51	0.87	1.23	1.59	1.95	2.31	2.67	3.03	3.39
150	5.73	9.77	13.82	17.86	21.91	25.95	29.99	34.04	38.08	
	3.81	0.53	0.91	1.28	1.66	2.04	2.41	2.79	3.16	3.54
156	5.97	10.19	14.40	18.62	22.84	27.05	31.27	35.48	39.70	
	3.96	0.55	0.95	1.34	1.73	2.12	2.51	2.90	3.30	3.69
162	6.22	10.60	14.99	19.38	23.77	28.15	32.54	36.93	41.32	
	4.11	0.58	0.99	1.39	1.80	2.21	2.62	3.02	3.43	3.84
168	6.46	11.02	15.58	20.14	24.70	29.26	33.82	38.38	42.93	
	4.27	0.60	1.02	1.45	1.87	2.29	2.72	3.14	3.57	3.99
174	6.70	11.43	16.16	20.90	25.63	30.36	35.09	39.82	44.55	
	4.42	0.62	1.06	1.50	1.94	2.38	2.82	3.26	3.70	4.14
180	6.95	11.85	16.75	21.65	26.56	31.46	36.36	41.27	46.17	
	4.57	0.65	1.10	1.56	2.01	2.47	2.92	3.38	3.83	4.29
186	7.19	12.26	17.34	22.41	27.49	32.56	37.64	42.71	47.79	
	4.72	0.67	1.14	1.61	2.08	2.55	3.03	3.50	3.97	4.44
192	7.43	12.68	17.93	23.17	28.42	33.66	38.91	44.16	49.40	
	4.88	0.69	1.18	1.67	2.15	2.64	3.13	3.61	4.10	4.59
198	7.68	13.09	18.51	23.93	29.35	34.77	40.18	45.60	51.02	
	5.03	0.71	1.22	1.72	2.22	2.73	3.23	3.73	4.24	4.74
204	6.93	12.52	18.11	23.70	29.29	34.88	40.47	46.06	48.86	
	5.18	0.64	1.16	1.68	2.20	2.72	3.24	3.76	4.28	4.54

Upper Numerals English Units/Lower Numerals Metric Units