

COLOR:
WOOD SPECIES: _____
WOOD FINISH: _____
 PLEASE ADVISE WOOD SPECIES AND WOOD FINISH. REFER TO C/S CATALOG FOR OPTIONS

ACROVYN BRACKET COLOR: _____
 COLOR TO BE SELECTED FROM ONE OF C/S STANDARD COLORS.

TOTAL L/F REQ'D	END CAPS	O.S.C. REQ'D

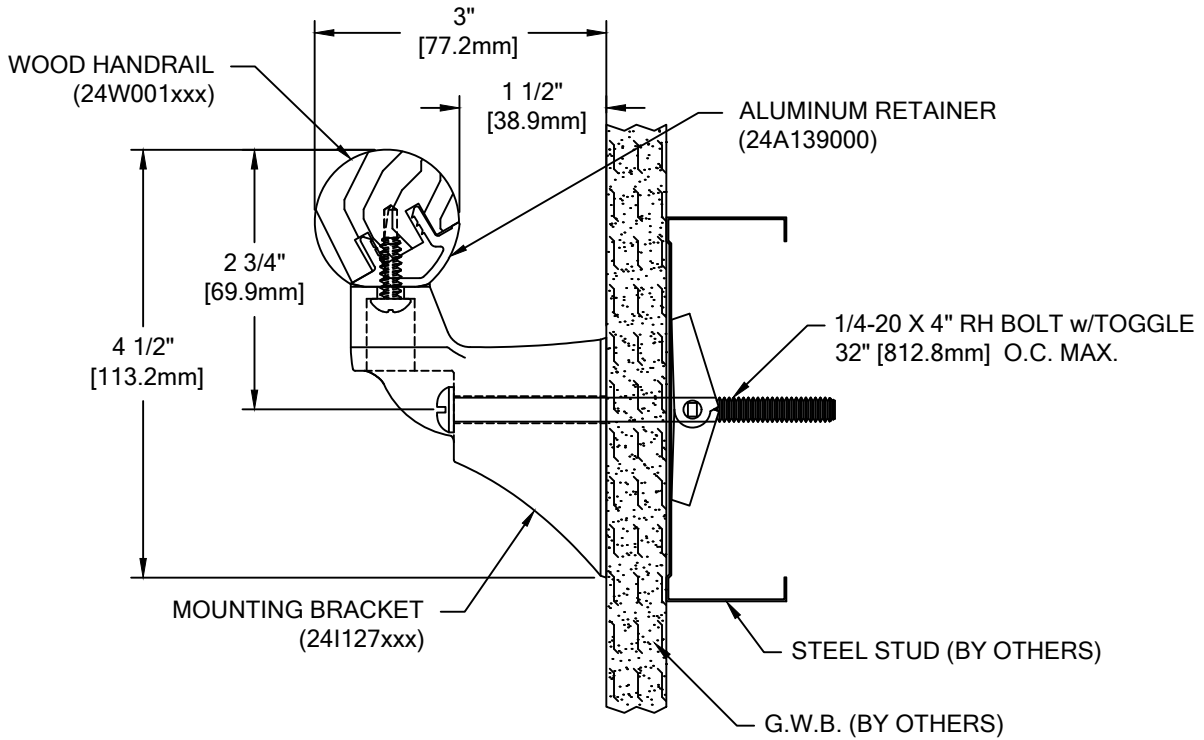

HRW-6C

WALL CONDITION	SPECIFIED FASTENER	DRILL DIAMETERS		C/S PART NUMBER
		WALL	RETAINER	
STEEL STUD/GYPSUM WALL	1/4-20 X 4" ROUND HEAD BOLT WITH TOGGLE	3/4"	N/A	90H059002
CONCRETE/CONCRETE BLOCK	#14 X 4" PH. RD. ALL-PURPOSE SCREW	7/32"	N/A	90H225002
WOOD STUD/GYPSUM WALL	#14 X 4" PH. RD. ALL-PURPOSE SCREW	7/32"	N/A	90H225002
16 GA. MIN. STEEL STUD AND 16 GA. MIN. STEEL STRAPPING / GYPSUM WALL CONSTRUCTION REQUIRED (TEK SCREWS)	#14 X 5" PHILLIPS PAN HEAD #3 SELF DRILLING TEK SCREW ZINC PLATED	N/A	N/A	90H286001

 Hughesville, PA 800.233.8493 570.546.5941 Mississauga, ON 888.895.8955 905.274.3611 www.c-sgroup.com © Copyright 2018 Construction Specialties, Inc.	PROJECT:	REVISION:
	JOB NO.:	F&F:
	CUSTOMER:	
	REP:	DATE:
	DRAWN BY:	SHEET NO: