

PEDIMAT AA WITH RECESSED TAPERED ANGLE FRAME / TRIMMABLE EDGE ON ALL SIDES

INSERT STYLE:

INSERT COLOR: PLEASE ADVISE

CATALOG NUMBER: M2

PART NUMBER:

NO.	REVISION	DATE	BY
NO.	F&F RELEASE	DATE	BY

 RECYCLED RUBBER M2RR 19R005XXX	 EXTERIOR CARPET M2EC 19C018XXX	 HEAVY-DUTY CARPET M2HC 19C010XXX 19C022XXX	 RUBBER M2V 19V022501 #8501 BLACK	 VINYL ABRASIVE M2VA 19A007XXX 19M001XXX	 SERRATED ALUM. INSERT M2SAI 19A001001
---	---	--	--	--	--

PEDIMAT AA INSERT STYLES

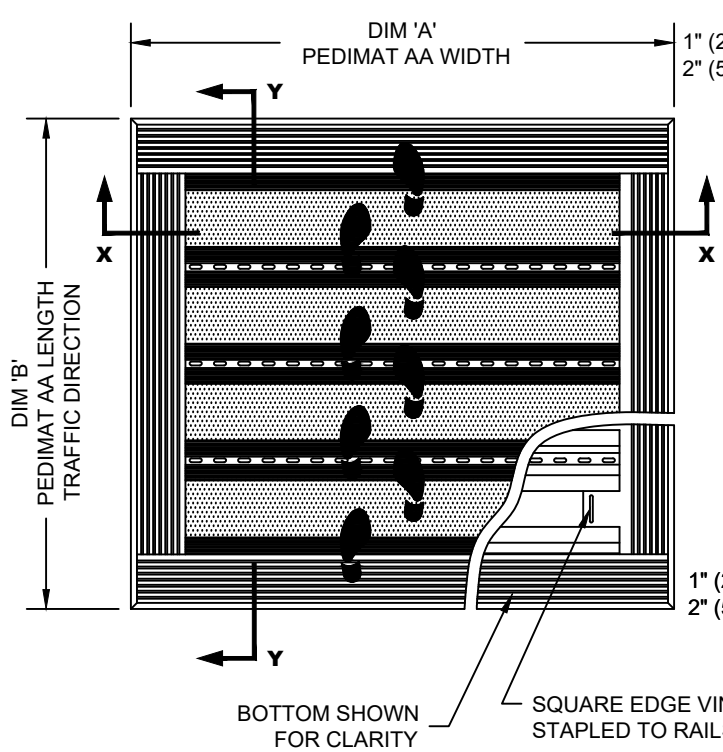

TYPICAL PLAN VIEW

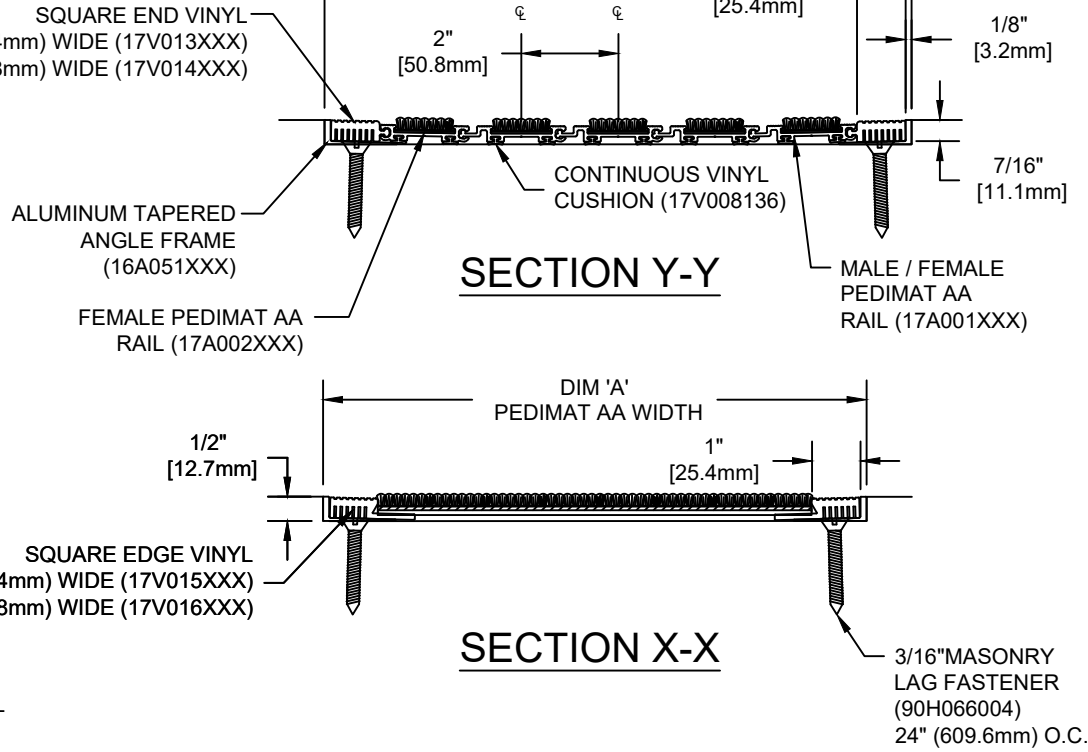

NOTES:

- *ALL SURFACES IN CONTACT WITH MASONRY ARE TO RECEIVE A COAT OF ZINC CHROMATE PRIMER
- *MAX. SINGLE GRID SIZE NOT TO EXCEED 12'-0" (3.66M) IN WIDTH (DIM "A") OR 100 SQUARE FEET
- *PLEASE VERIFY TRAFFIC DIRECTION
- *PEDIMAT AA SHALL BE ABLE TO SUPPORT A 350 LB. ROLLING LOAD. LARGER LOADING MAY BE ACCOMMODATED. CONTACT C/S SALES WITH SPECIFIC LOADING REQUIREMENTS.
- *ADDITIONAL SPECIFICATIONS ARE CONTAINED IN THE LATEST C/S CATALOG OR AT C-SGROUP.COM AND ARE CONSIDERED PART OF THIS TRANSMITTAL.

CS Construction Specialties
 6696 Route 405 Highway, Muncy PA 17756
 (800) 233-8493 • Fax (570) 546-4692 • www.c-sgroup.com

PLEASE VERIFY ALL	QTY	MARK #	LOCATION	MODEL	DIM 'A' WIDTH	DIM 'B' LENGTH	FINISH	NOTES

PROJECT:		
LOCATION:		
CONTRACTOR:		
AGENT:		SHT:
DRG. BY:	DATE:	JOB NO.: