

COLOR: _____
 HANDRAIL WOOD SPECIES: _____
 HANDRAIL WOOD FINISH: _____
 COLOR TO BE SELECTED FROM ONE OF C/S STANDARD COLORS.

TOTAL L/F REQ'D	LEFT END CAPS	RIGHT END CAPS

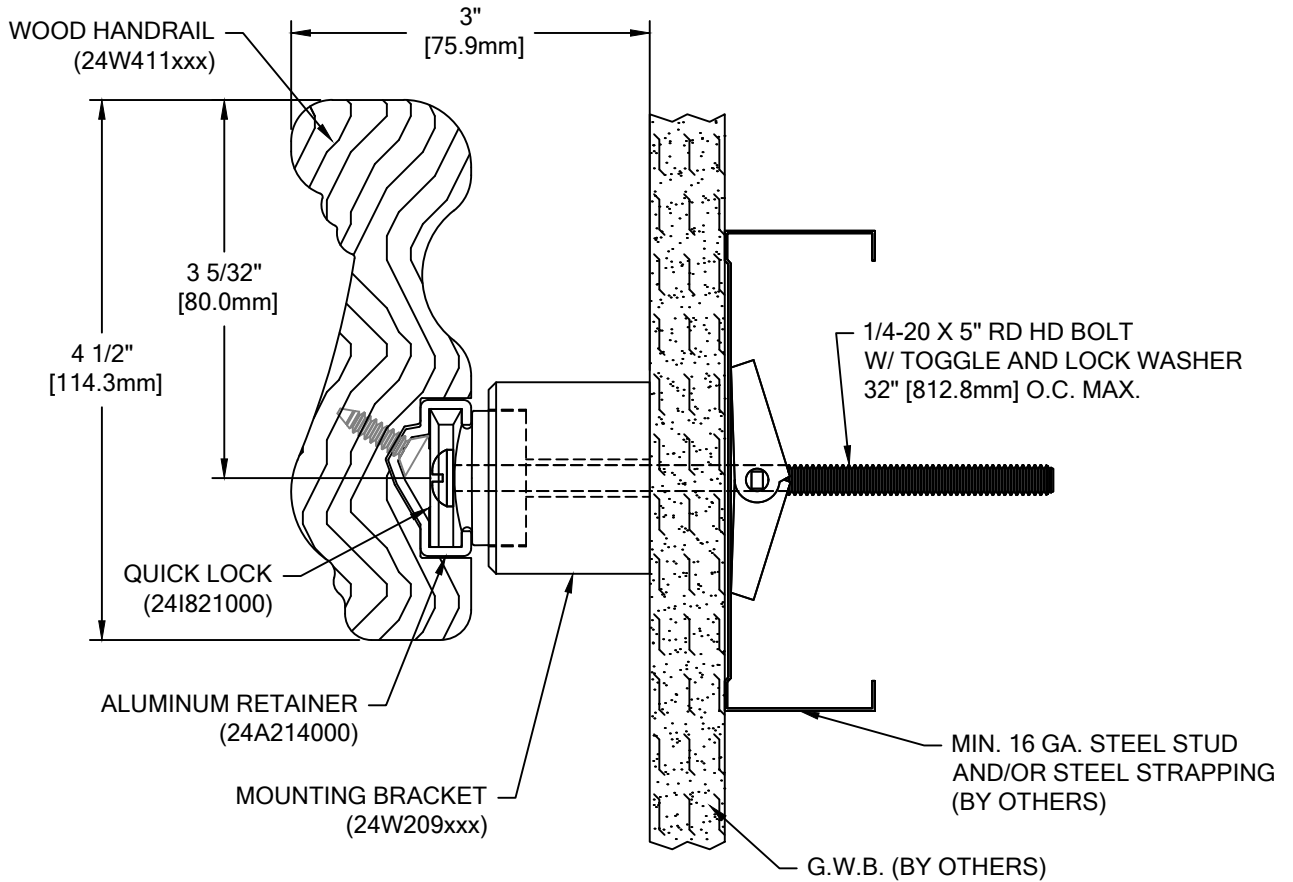

HRW-45

WALL CONDITION	SPECIFIED FASTENER	DRILL DIAMETERS		C/S PART NUMBER
		WALL	RETAINER	
STEEL STUD/GYPSUM WALL	1/4-20 X 5" ROUND HEAD BOLT WITH TOGGLE, AND LOCK WASHER	3/4"	N/A	90H049002 90H006003
CONCRETE/CONCRETE BLOCK	#14 X 5" PHILLIPS RD HD ALL-PURPOSE SCREW	3/16"	N/A	90H287002
WOOD STUD/GYPSUM WALL	#14 X 5" PHILLIPS RD HD ALL-PURPOSE SCREW	1/8"	N/A	90H287002
16 GA. MIN. STEEL STUD AND 16 GA. MIN. STEEL STRAPPING / GYPSUM WALL CONSTRUCTION REQUIRED (TEK SCREWS)	#14 X 5" PHILLIPS PAN HEAD #3 SELF DRILLING TEK SCREW ZINC PLATED	N/A	N/A	90H286001

FABRICATION AND APPEARANCE OF THIS WOOD RAIL MATERIAL IS BASED ON FACTORY CUT AND ATTACHED END CAPS. IF STOCK SIZES ARE REQUIRED, END CAPS MUST BE CUT IN THE FIELD BY INSTALLER OR C/S WILL NOT GUARANTEE MATCH AND APPEARANCE OF CAPS TO RAIL.

 Hughesville, PA 800.233.8493 570.546.5941 Mississauga, ON 888.895.8955 905.274.3611 www.c-sgroup.com © Copyright 2018 Construction Specialties, Inc.	PROJECT:	REVISION:
	JOB NO.:	F&F:
	CUSTOMER:	
	REP:	DATE:
	DRAWN BY:	SHEET NO: